



Mobile Cylinder Div. Standard Build Series

Catalog HY18-0014/US Rev C

aerospace
climate control
electromechanical
filtration
fluid & gas handling
hydraulics
pneumatics
process control
sealing & shielding



ENGINEERING YOUR SUCCESS.

 **WARNING - USER RESPONSIBILITY**

FAILURE OR IMPROPER SELECTION OR IMPROPER USE OF THE PRODUCTS DESCRIBED HEREIN OR RELATED ITEMS CAN CAUSE DEATH, PERSONAL INJURY AND PROPERTY DAMAGE.

This document and other information from Parker-Hannifin Corporation, its subsidiaries and authorized distributors provide product or system options for further investigation by users having technical expertise.

The user, through its own analysis and testing, is solely responsible for making the final selection of the system and components and assuring that all performance, endurance, maintenance, safety and warning requirements of the application are met. The user must analyze all aspects of the application, follow applicable industry standards, and follow the information concerning the product in the current product catalog and in any other materials provided from Parker or its subsidiaries or authorized distributors.

To the extent that Parker or its subsidiaries or authorized distributors provide component or system options based upon data or specifications provided by the user, the user is responsible for determining that such data and specifications are suitable and sufficient for all applications and reasonably foreseeable uses of the components or systems.

Offer of Sale

The items described in this document are hereby offered for sale by Parker Hannifin Corporation, its subsidiaries or its authorized distributors. This offer and its acceptance are governed by the provisions stated in the "Offer of Sale".

© Copyright 2009, Parker Hannifin Corporation, All Rights Reserved

Table of Contents

Series Design.....	4-5
Main Barrel and Rod Coding	6-7
How to Order Standard Build Series Cylinders	8-9
Body / Main Barrel Mount Code	10-16
Rod End Mount Code.....	17-28
Rod Extension, Stop Tube and Ports	29
Cylinder, Special Options	30
Cylinder Mounting Accessories.....	31-34
Piston Rod Cylinder Application Data Form.....	35
Service Parts and Kits.....	36-37
Designing With Cylinders	38-45
Hydraulic Oil Recommendations	46
Hydraulic Cylinder Formulas.....	47
Storage and Installation.....	48
Safety Guidelines for Mobile Cylinder Division Products	49
Offer of Sale	50

Series Design

WMD Series, 2500 PSI

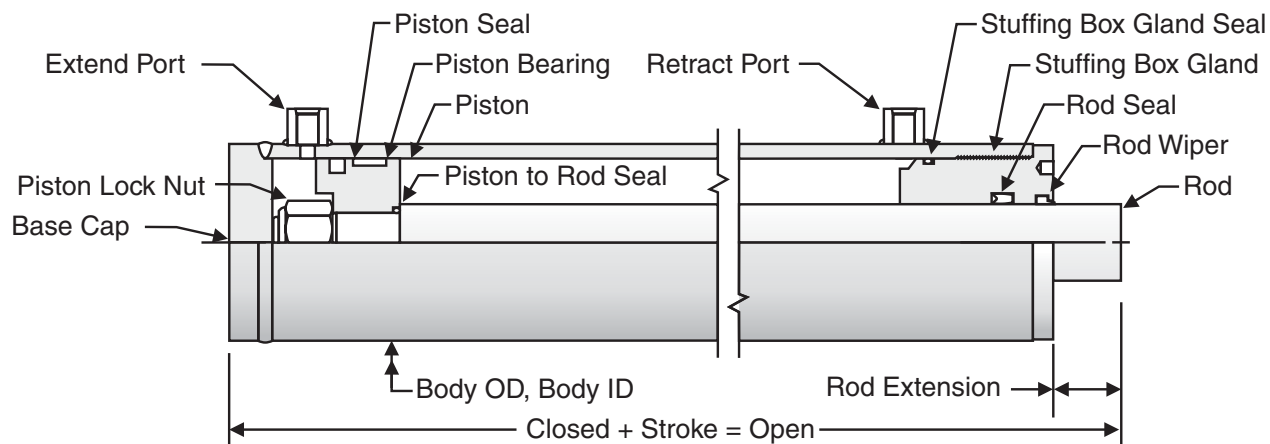

Standard Construction:

Pressure Rating: 2500 p.s.i.

Standard Operating Temperature Range: -10° F (-23° C) to +165° F (+74° C).

Standard Seals Suited for operation with mineral base hydraulic fluid.

Body / Main Barrel Material: High strength steel tubing per ASTM 513 with a minimum Yield Strength of 75,000 p.s.i., finished to a maximum 16 micro-inch finish for long seal life.

Piston Rod Material, Standard: Medium carbon steel with a minimum Yield Strength of 100,000 p.s.i. (4.50" dia. Rod slightly lower). Case hardened to a minimum of 50 Rockwell C scale to prevent accidental damage. Hard chrome plated and polished to 10 RMS to provide long seal life.

Stuffing Box / Gland: Gland constructed of high strength ductile iron, Buttress Thread Design.

Piston: One-piece, pilot fitted, ductile iron material. Secured to the rod by an elastic lock nut to insure a positive connection.

Optional Nitrated Bar Rod Material, "N" Code: Steel bar with a minimum 75,000 p.s.i. Yield Strength to 16 RMS and processed for corrosion resistance.

Optional Stainless Steel Rod Material, "S" Code: High strength stainless steel which provides both high strength and corrosion resistance.

Standard Seals:

Rod Seal: Polyurethane for long seal life.

Rod Wiper: Polyurethane with double lip design to help in sealing and providing excellent exclusion protection.

Piston Seal: Buna-N energized bronze filled Teflon slide ring.

Bearings: Wear band bearings provide side load protection. Internally lubricated, heat stabilized, glass filled nylon.

O-Rings: Buna-N

Back Up Ring: Nitrile

Optional Seals for Special Fluids and Abnormal Temperatures: Contact Factory for High Temperature (Fluorocarbon), Low Temperature (Special Nitrile), Water, Water-Glycol and Phosphatate Ester (E.P.R.) Seals.

All of our cylinders utilize the latest in seal design. Seals are one of the most critical components in a hydraulic cylinder. It is very important to keep the nearby operating environment as clean as possible and to keep the oil as contaminant free as possible.

WHD Series, 3000 PSI

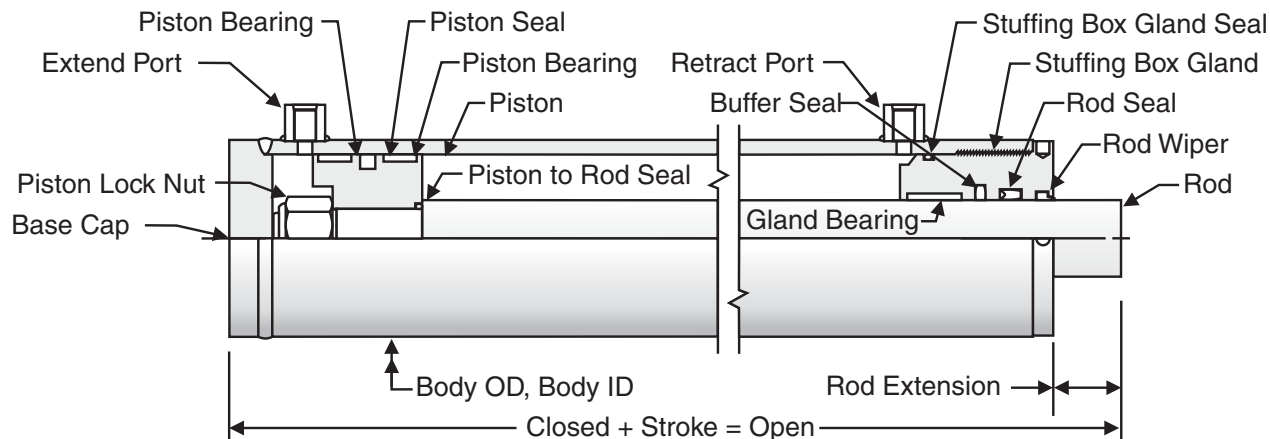

Standard Construction:

Pressure Rating: 3000 p.s.i.

Standard Operating Temperature Range: -10° F (-23° C) to +165° F (+74° C).

Standard Seals Suited for operation with mineral base hydraulic fluid.

Body / Main Barrel Material: High strength steel tubing per ASTM 513 with a minimum Yield Strength of 75,000 p.s.i., finished to a maximum 16 micro-inch finish for long seal life.

Piston Rod Material, Standard: Medium carbon steel with a minimum Yield Strength of 100,000 p.s.i. (4.50" dia. Rod slightly lower). Case hardened to a minimum of 50 Rockwell C scale to prevent accidental damage. Hard chrome plated and polished to 10 RMS to provide long seal life.

Stuffing Box / Gland: Gland constructed of high strength ductile iron, Buttress Thread Design.

Piston: One-piece, pilot fitted, ductile iron material. Secured to the rod by an elastic lock nut to insure a positive connection.

Optional Nitrated Rod Material, "N" Code: Steel bar with a minimum 75,000 p.s.i. Yield Strength to 16 RMS and processed for corrosion resistance.

Optional Stainless Steel Rod Material, "S" Code: High strength stainless steel which provides both high strength and corrosion resistance.

Standard Seals:

Rod Seal: Polyurethane for long seal life.

Rod Wiper: Polyurethane with double lip design to help in sealing and providing excellent exclusion protection.

Rod Buffer (std): Premier Grade Urethane, Buffer seal acts as the primary seal to limit pressure at the Rod Seal.

Piston Seal: Buna-N energized bronze filled Teflon slide ring.

Bearings: Wear band bearings provide side load protection. Internally lubricated, heat stabilized, glass filled nylon.

O-Rings: Buna-N

Back Up Ring: Nitrile

Optional Seals for Special Fluids and Abnormal Temperatures: Contact Factory for High Temperature (Fluorocarbon), Low Temperature (Special Nitrile), Water, Water-Glycol and Phosphatate Ester (E.P.R.) Seals.

All of our cylinders utilize the latest in seal design. Seals are one of the most critical components in a hydraulic cylinder. It is very important to keep the nearby operating environment as clean as possible and to keep the oil as contaminant free as possible.

Main Barrel and Rod Coding

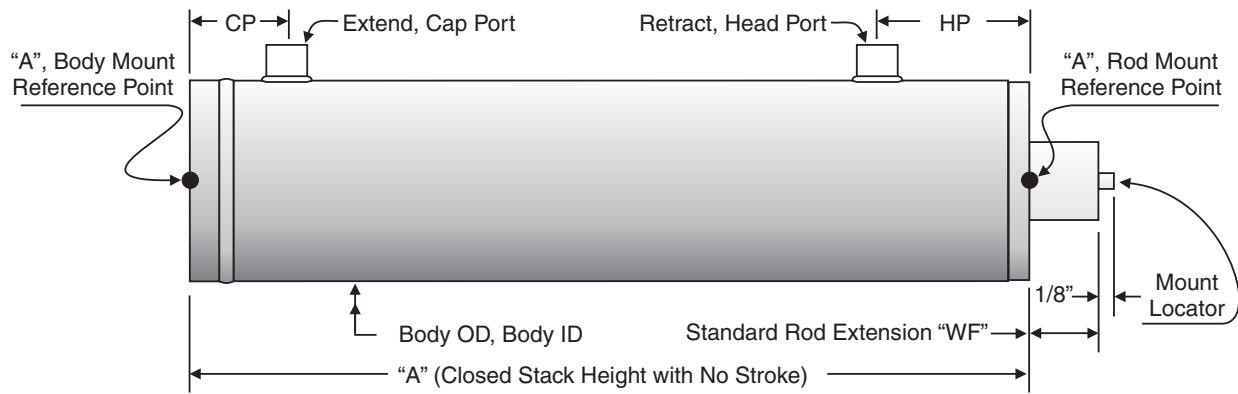

Bore Code	Body Bore and O.D. Diameter	Rod Diameter	Rod Code	WMD Series					WHD Series				
				A	Std. WF	Ports			A	Std. WF	Ports		
						Size	CP	HP			Size	CP	HP
20	2.00" ID x 2.50" OD	1.00"	10	4.62"	0.88"	#6 SAE	1.12"	2.25"	N/A	N/A	N/A	N/A	N/A
		1.125"	11	4.62"	0.88"	#6 SAE	1.12"	2.25"	N/A	N/A	N/A	N/A	N/A
		1.25"	12	4.62"	0.88"	#6 SAE	1.12"	2.25"	N/A	N/A	N/A	N/A	N/A
25	2.50" ID x 3.00" OD	1.00"	10	5.00"	0.88"	#6 SAE	1.25"	2.56"	N/A	N/A	N/A	N/A	N/A
		1.125"	11	5.00"	0.88"	#6 SAE	1.25"	2.56"	N/A	N/A	N/A	N/A	N/A
		1.25"	12	5.00"	0.88"	#6 SAE	1.25"	2.56"	N/A	N/A	N/A	N/A	N/A
		1.375"	13	5.00"	0.88"	#6 SAE	1.25"	2.56"	N/A	N/A	N/A	N/A	N/A
		1.50"	15	5.00"	0.88"	#6 SAE	1.25"	2.56"	N/A	N/A	N/A	N/A	N/A
30	3.00" ID x 3.50" OD	1.00"	10	5.31"	0.88"	#6 SAE	1.37"	2.56"	N/A	N/A	N/A	N/A	N/A
		1.125"	11	5.31"	0.88"	#6 SAE	1.37"	2.56"	N/A	N/A	N/A	N/A	N/A
		1.25"	12	5.31"	0.88"	#6 SAE	1.37"	2.56"	N/A	N/A	N/A	N/A	N/A
		1.375"	13	5.31"	0.88"	#6 SAE	1.37"	2.56"	6.38"	0.88"	#6 SAE	1.50"	2.88"
		1.50"	15	5.31"	0.88"	#6 SAE	1.37"	2.56"	6.38"	0.88"	#6 SAE	1.50"	2.88"
		1.75"	17	5.31"	0.88"	#6 SAE	1.37"	2.56"	6.38"	0.88"	#6 SAE	1.50"	2.88"
32	3.25" I.D. x 3.75" O.D.	1.25"	12	5.44"	0.88"	#8 SAE	1.50"	2.56"	6.56"	0.88"	#8 SAE	1.62"	2.88"
		1.375"	13	5.44"	0.88"	#8 SAE	1.50"	2.56"	6.56"	0.88"	#8 SAE	1.62"	2.88"
		1.50"	15	5.44"	0.88"	#8 SAE	1.50"	2.56"	6.56"	0.88"	#8 SAE	1.62"	2.88"
		1.75"	17	5.44"	0.88"	#8 SAE	1.50"	2.56"	6.56"	0.88"	#8 SAE	1.62"	2.88"
		2.00"	20	5.44"	0.88"	#8 SAE	1.50"	2.56"	6.56"	0.88"	#8 SAE	1.62"	2.88"
35	3.50" ID x 4.00" OD	1.25"	12	5.69"	0.88"	#8 SAE	1.50"	2.81"	6.69"	0.88"	#8 SAE	1.75"	2.88"
		1.375"	13	5.69"	0.88"	#8 SAE	1.50"	2.81"	6.69"	0.88"	#8 SAE	1.75"	2.88"
		1.50"	15	5.69"	0.88"	#8 SAE	1.50"	2.81"	6.69"	0.88"	#8 SAE	1.75"	2.88"
		1.75"	17	5.69"	0.88"	#8 SAE	1.50"	2.81"	6.69"	0.88"	#8 SAE	1.75"	2.88"
		2.00"	20	5.69"	0.88"	#8 SAE	1.50"	2.81"	6.69"	0.88"	#8 SAE	1.75"	2.88"
		2.50"	25	5.69"	0.88"	#8 SAE	1.50"	2.81"	6.69"	0.88"	#8 SAE	1.75"	2.88"
40	4.00" ID x 4.62" OD	1.375"	13	5.81"	0.88"	#8 SAE	1.62"	2.81"	7.31"	0.88"	#8 SAE	1.88"	3.38"
		1.50"	15	5.81"	0.88"	#8 SAE	1.62"	2.81"	7.31"	0.88"	#8 SAE	1.88"	3.38"
		1.75"	17	5.81"	0.88"	#8 SAE	1.62"	2.81"	7.31"	0.88"	#8 SAE	1.88"	3.38"
		2.00"	20	5.81"	0.88"	#8 SAE	1.62"	2.81"	7.31"	0.88"	#8 SAE	1.88"	3.38"
		2.50"	25	5.81"	0.88"	#8 SAE	1.62"	2.81"	7.31"	0.88"	#8 SAE	1.88"	3.38"
		3.00"	30	5.81"	0.88"	#8 SAE	1.62"	2.81"	7.31"	0.88"	#8 SAE	1.88"	3.38"

Standard Build Cylinders in any practical stroke length required up to 120" gross with standard "A" closed dimension (including fractional inches) with choice of cataloged rod ends. For stroke lengths over 120" consult factory.

Note: If stop tubing is required, apply the stroke adder for the required cylinder GROSS stroke, then apply appropriate stop tube base & length adder per price list, which will achieve required NET Stroke.

Note: Please contact factory for Nitro and Stainless rod material availability.

Main Barrel and Rod Coding

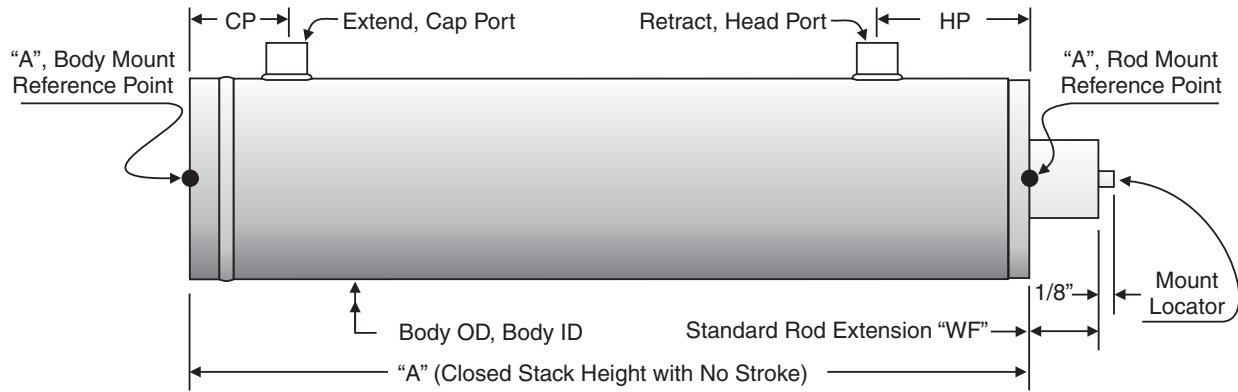

Bore Code	Body Bore and O.D. Diameter	Rod Diameter	Rod Code	WMD Series					WHD Series				
				A	Std. WF	Ports			A	Std. WF	Ports		
						Size	CP	HP			Size	CP	HP
45	4.50" ID x 5.12" OD	1.75"	17	5.94"	0.88"	#8 SAE	1.75"	2.81"	7.69"	0.88"	#10 SAE	2.25"	3.38"
		2.00"	20	5.94"	0.88"	#8 SAE	1.75"	2.81"	7.69"	0.88"	#10 SAE	2.25"	3.38"
		2.50"	25	5.94"	0.88"	#8 SAE	1.75"	2.81"	7.69"	0.88"	#10 SAE	2.25"	3.38"
		3.00"	30	5.94"	0.88"	#8 SAE	1.75"	2.81"	7.69"	0.88"	#10 SAE	2.25"	3.38"
		3.50"	35	5.94"	0.88"	#8 SAE	1.75"	2.81"	7.69"	0.88"	#10 SAE	2.25"	3.38"
50	5.00" ID x 5.62" OD	2.00"	20	6.31"	0.88"	#8 SAE	2.00"	2.81"	8.25"	0.88"	#12 SAE	2.38"	3.63"
		2.50"	25	6.31"	0.88"	#8 SAE	2.00"	2.81"	8.25"	0.88"	#12 SAE	2.38"	3.63"
		3.00"	30	6.31"	0.88"	#8 SAE	2.00"	2.81"	8.25"	0.88"	#12 SAE	2.38"	3.63"
		3.50"	35	6.31"	0.88"	#8 SAE	2.00"	2.81"	8.25"	0.88"	#12 SAE	2.38"	3.63"
		4.00"	40	6.31"	0.88"	#8 SAE	2.00"	2.81"	8.25"	0.88"	#12 SAE	2.38"	3.63"
55	5.50" ID x 6.25" OD	2.50"	25	N/A	N/A	N/A	N/A	N/A	8.25"	0.88"	#12 SAE	2.44"	3.63"
		3.00"	30	N/A	N/A	N/A	N/A	N/A	8.25"	0.88"	#12 SAE	2.44"	3.63"
		3.50"	35	N/A	N/A	N/A	N/A	N/A	8.25"	0.88"	#12 SAE	2.44"	3.63"
		4.00"	40	N/A	N/A	N/A	N/A	N/A	8.25"	0.88"	#12 SAE	2.44"	3.63"
		4.50"	45	N/A	N/A	N/A	N/A	N/A	8.25"	0.88"	#12 SAE	2.44"	3.63"
60	6.00" ID x 6.75" OD	2.50"	25	N/A	N/A	N/A	N/A	N/A	8.25"	0.88"	#12 SAE	2.44"	3.63"
		3.00"	30	N/A	N/A	N/A	N/A	N/A	8.25"	0.88"	#12 SAE	2.44"	3.63"
		3.50"	35	N/A	N/A	N/A	N/A	N/A	8.25"	0.88"	#12 SAE	2.44"	3.63"
		4.00"	40	N/A	N/A	N/A	N/A	N/A	8.25"	0.88"	#12 SAE	2.44"	3.63"
		4.50"	45	N/A	N/A	N/A	N/A	N/A	8.25"	0.88"	#12 SAE	2.44"	3.63"
70	7.00" ID x 7.75" OD	2.50"	25	N/A	N/A	N/A	N/A	N/A	8.75"	0.88"	#16 SAE	2.44"	4.00"
		3.00"	30	N/A	N/A	N/A	N/A	N/A	8.75"	0.88"	#16 SAE	2.44"	4.00"
		3.50"	35	N/A	N/A	N/A	N/A	N/A	8.75"	0.88"	#16 SAE	2.44"	4.00"
		4.00"	40	N/A	N/A	N/A	N/A	N/A	8.75"	0.88"	#16 SAE	2.44"	4.00"
		4.50"	45	N/A	N/A	N/A	N/A	N/A	8.75"	0.88"	#16 SAE	2.44"	4.00"
80	8.00" ID x 9.00" OD	3.50"	35	N/A	N/A	N/A	N/A	N/A	9.69"	0.88"	#16 SAE	2.69"	4.00"
		4.00"	40	N/A	N/A	N/A	N/A	N/A	9.69"	0.88"	#16 SAE	2.69"	4.00"
		4.50"	45	N/A	N/A	N/A	N/A	N/A	9.69"	0.88"	#16 SAE	2.69"	4.00"

The Completed Cylinder Overall Closed Dimension will Equal Following;

- the "A" Dimension (from main barrel and rod coding page)
 - + the Base Mount "L" or "LT" Dimension (from base mount code page)
 - + the Rod Mount "WF" Dimension (from rod mount code page)
 - + the Rod Mount "CA" or "CE" or "CH" Dimension (from rod mount code page)
 - + the Gross Cylinder Stroke
 - + any Additional Rod Extension (if specified)
- = Overall Closed Dimension

Standard Build Cylinders in any practical stroke length required up to 120" gross with standard "A" closed dimension (including fractional inches) with choice of cataloged rod ends. For stroke lengths over 120" consult factory.

Note: If stop tubing is required, apply the stroke adder for the required cylinder GROSS stroke, then apply appropriate stop tube base & length adder per price list, which will achieve required NET Stroke.

Note: Please contact factory for Nitro and Stainless rod material availability.

How to Order Standard Build Series Cylinders

Part Number Ordering Example

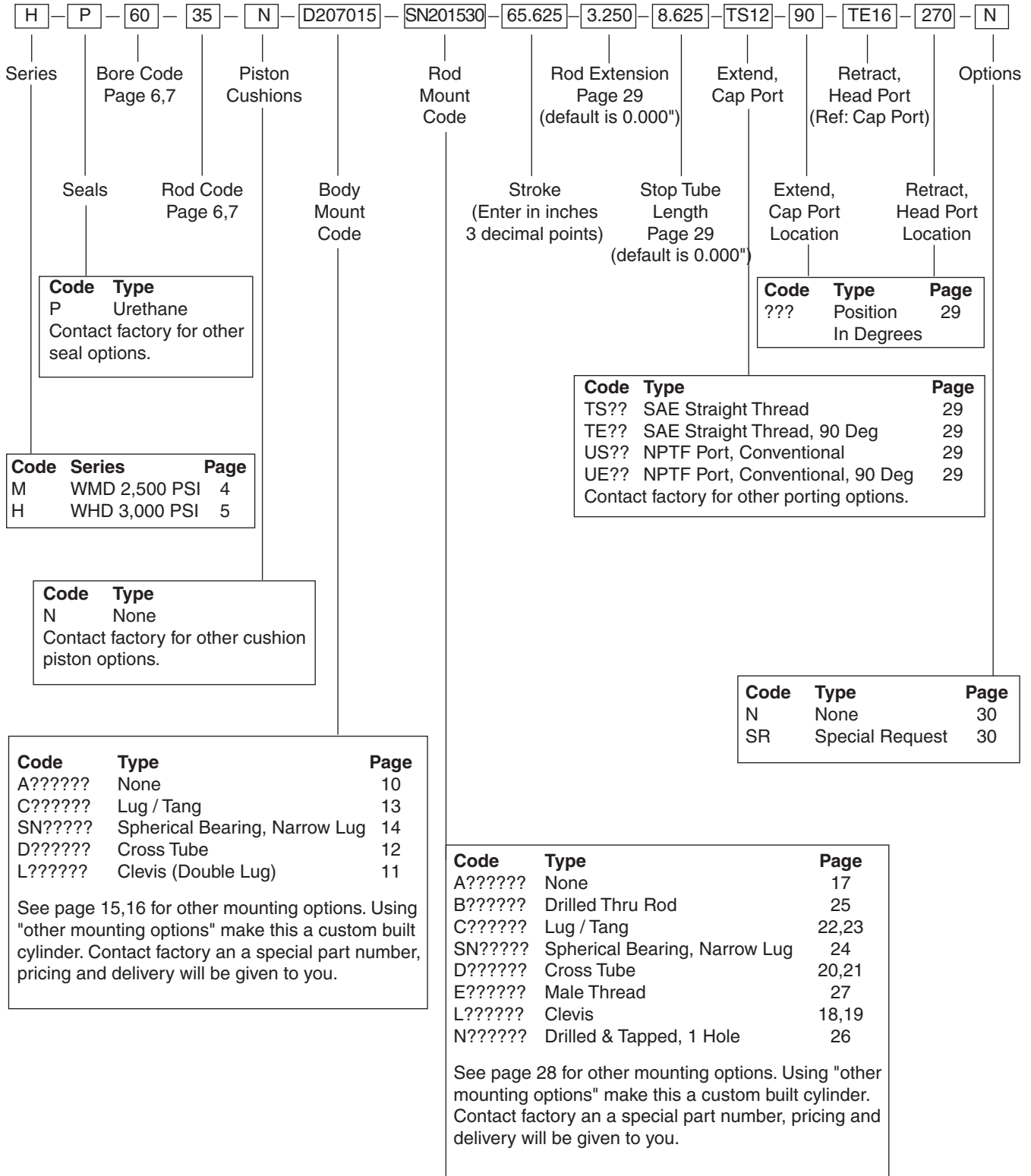

How to Order Standard Build Series Cylinders

Part Number Ordering Example

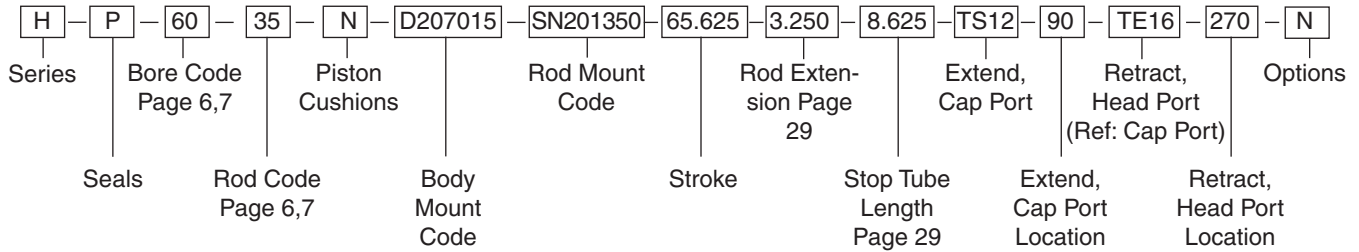
**Series:**

Enter series, reference page 4 and 5 (example, H for WHD 3,000 P.S.I.)

Seals:

Enter seal code P (example, P for Urethane).

Contact factory for seal material options.

Bore:

Enter cylinder bore code, reference page 6 and 7 (example, 60 for 6.00" inside diameter bore).

Rod:

Enter cylinder rod code, reference page 6 and 7 (example, 35 for 3.50" outside diameter rod).

Contact factory for rod material options.

Piston Cushions:

Enter cushion type code N (example, N for None).

Contact factory cushion options.

Body Mount:

Enter a Body Mount Code for the Bore Code selected, reference page 10-16 (example, D207015 for Cross Tube).

Rod Mount:

Enter a Rod Mount Code for the Rod Code selected, reference page 17-28 (example, SN201350 for Spherical Bearing/ Narrow Lug).

Stroke:

Enter cylinder stroke required in inches (example, 65.625", 3 decimal points).

Note: Standard Build Cylinders in any practical stroke length required up to 120" gross with standard "A" closed dimension (including fractional inches) with choice of cataloged rod ends. For stroke lengths over 120" consult factory.

Rod Extension:

Enter amount of additional rod extension required in inches if other than the standard catalog Rod Mount "WF" dimension, reference page 29 (example 3.250", 3 decimal points).

Note: This will effect over all closed length but the stroke.

Stop Tube Length:

Enter length of stop tube required in inches, reference page 29 (example; 8.625", 3 decimal points).

Note: If stop tubing is required, apply the stroke adder for the required cylinder GROSS stroke, then apply appropriate stop tube base & length adder per price list, which will achieve required NET Stroke. This will affect the over all stroke but not closed length. (Example; "A" = 8.81" + Stroke of 65.625" = 74.435" Closed and 140.06" Open Length, add 8.625" Stop Tube, 74.435" Closed remains the same but Net Stroke becomes 57.00" and the Open Length becomes 131.435".

Extend Cap Port:

Enter cap port type, reference page 29 (example, TS12 for #12 SAE Port).

Note: Unless otherwise specified as a "SR", with 90-degree elbows the port will face base of cylinder.

Extend Cap Port Location:

Enter location in degrees in reference to base end lug, reference page 29 (example, 90 for 90 degrees).

Retract Head Port:

Enter cap port type, reference page 29 (example, TE16 for #16 SAE 90 Degree Port).

Note: Unless otherwise specified as a "SR", with 90-degree elbows the port will face base of cylinder.

Retract Head Port Location:

Enter location in degrees in reference to base end lug, reference page 29 (example, 270 for 270 degrees).

Options:

Enter option code N, reference page 30.

Note: Please consult factory for the SR (Special Request) Option.

Body / Main Barrel Mount Code

"A" Body Mount Code, No Body Mounts

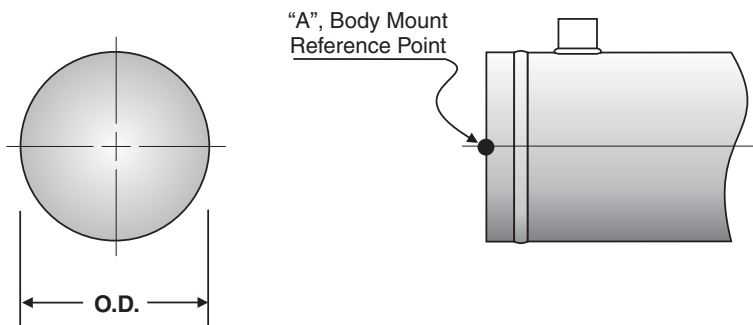

Body Code	Bore	Body Mount Code	Body O.D.
20	2.00" ID	A000000	2.50"
25	2.50" ID	A000000	3.00"
30	3.00" ID	A000000	3.50"
32	3.25" ID	A000000	3.75"
35	3.50" ID	A000000	4.00"
40	4.00" ID	A000000	4.62"
45	4.50" ID	A000000	5.12"
50	5.00" ID	A000000	5.62"
55	5.50" ID	A000000	6.25"
60	6.00" ID	A000000	6.75"
70	7.00" ID	A000000	7.75"
80	8.00" ID	A000000	9.00"

Body / Main Barrel Mount Code

"L" Body Mount Code, Clevis (Double Lug) Body Mounts

Some sizes dimensionally interchangeable with NFPA Style MP1

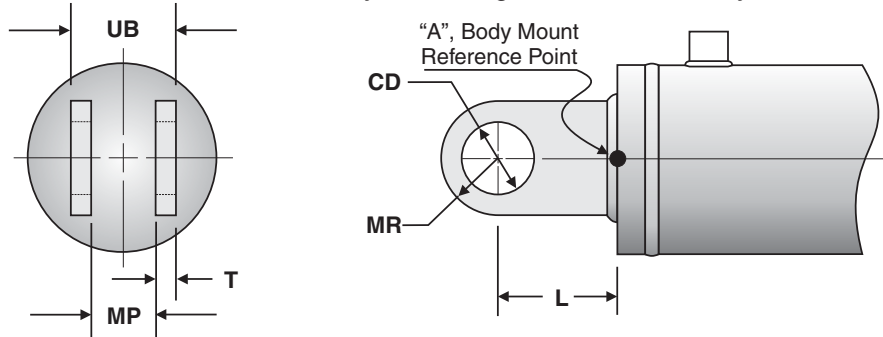

Body Code	Bore	Body Mount Code	Nominal Pin Size	Actual CD	Gap MP	Thickness T	Width UB	Radius MR	Length L	Max Pull at Yield *
20	2.00" ID	L071206	0.75"	0.752"	1.28"	0.62"	2.53"	0.75"	1.25"	20,000#
20	2.00" ID	L101205	1.00"	1.015"	1.28"	0.50"	2.28"	1.00"	2.00"	20,000#
25	2.50" ID	L071206	0.75"	0.752"	1.28"	0.62"	2.53"	0.75"	1.25"	20,000#
25	2.50" ID	L101205	1.00"	1.015"	1.28"	0.50"	2.28"	1.00"	2.00"	20,000#
30	3.00" ID	L101205	1.00"	1.015"	1.28"	0.50"	2.28"	1.00"	2.00"	20,000#
32	3.25" ID	L101507	1.00"	1.015"	1.52"	0.75"	3.02"	1.12"	1.50"	30,000#
35	3.50" ID	L101205	1.00"	1.015"	1.28"	0.50"	2.28"	1.00"	2.00"	20,000#
35	3.50" ID	L121607	1.25"	1.265"	1.62"	0.75"	3.13"	1.25"	2.00"	30,000#
40	4.00" ID	L101205	1.00"	1.015"	1.28"	0.50"	2.28"	1.00"	2.00"	20,000#
40	4.00" ID	L132010	1.38"	1.390"	1.62"	1.00"	4.03"	1.62"	2.12"	45,000#
40	4.00" ID	L151610	1.50"	1.515"	1.62"	1.00"	3.62"	1.50"	2.00"	50,000#
45	4.50" ID	L121607	1.25"	1.265"	1.62"	0.75"	3.12"	1.25"	2.00"	45,000#
45	4.50" ID	L151610	1.50"	1.515"	1.62"	1.00"	3.62"	1.50"	2.00"	50,000#
50	5.00" ID	L152110	1.50"	1.515"	2.12"	1.00"	4.12"	1.50"	2.50"	50,000#
50	5.00" ID	L172110	1.75"	1.765"	2.12"	1.00"	4.12"	1.75"	2.25"	60,000#
50	5.00" ID	L172512	1.75"	1.765"	2.52"	1.25"	5.02"	2.12"	2.25"	100,000#
55	5.50" ID	L172112	1.75"	1.765"	2.12"	1.25"	4.62"	1.75"	2.25"	75,000#
60	6.00" ID	L202512	2.00"	2.015"	2.52"	1.25"	5.02"	2.38"	2.50"	120,000#
60	6.00" ID	L202612	2.00"	2.015"	2.62"	1.25"	5.12"	2.00"	2.50"	90,000#
70	7.00" ID	L252612	2.50"	2.515"	2.62"	1.25"	5.12"	2.50"	3.00"	110,000#
70	7.00" ID	L253015	2.50"	2.515"	3.02"	1.50"	6.02"	2.88"	3.00"	90,000#
80	8.00" ID	L303015	3.00"	3.015"	3.02"	1.50"	6.02"	3.12"	3.25"	170,000#
80	8.00" ID	L303115	3.00"	3.015"	3.12"	1.50"	6.12"	3.00"	4.00"	160,000#

* Max Pull Yield is based on a 2:1 safety factor

Body Mount Code Description = $\frac{L}{Code}$ $\frac{07}{Pin\ Size}$ $\frac{12}{Gap}$ $\frac{06}{Thickness}$

Note: Other mounts sizes available.

Note: Mounts also available with optional bushings.

Body / Main Barrel Mount Code

"D" Body Mount Code, Cross Tube Body Mounts

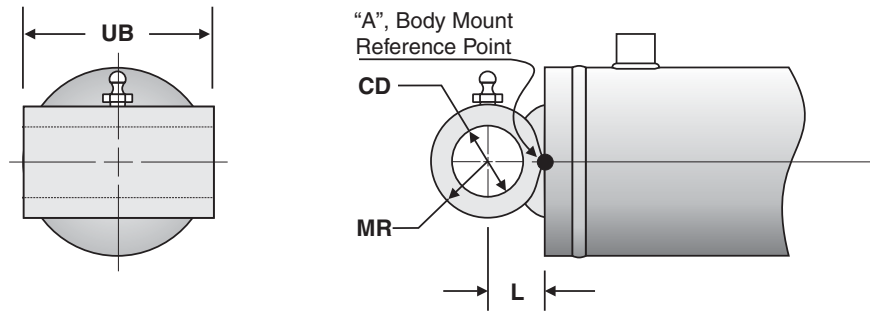

Body Code	Bore	Body Mount Code	Nominal Pin Size	Actual CD	Width UB	Length L	Radius MR	Max Pull at Yield *
20	2.00" ID	D103009	1.00"	1.015"	3.00"	0.81"	0.88"	15,000#
25	2.50" ID	D103209	1.00"	1.015"	3.25"	0.81"	0.88"	15,000#
30	3.00" ID	D103709	1.00"	1.015"	3.75"	0.81"	0.88"	20,000#
30	3.00" ID	D124210	1.25"	1.265"	4.25"	0.94"	1.00"	20,000#
32	3.25" ID	D124210	1.25"	1.265"	4.25"	0.94"	1.00"	25,000#
35	3.50" ID	D124210	1.25"	1.265"	4.25"	0.94"	1.00"	27,500#
40	4.00" ID	D124710	1.25"	1.265"	4.75"	0.94"	1.00"	35,000#
40	4.00" ID	D154712	1.50"	1.515"	4.75"	1.12"	1.25"	32,500#
45	4.50" ID	D125210	1.25"	1.265"	5.25"	0.94"	1.00"	42,500#
45	4.50" ID	D155512	1.50"	1.515"	5.50"	1.12"	1.25"	42,500#
50	5.00" ID	D156012	1.50"	1.515"	6.00"	1.12"	1.25"	50,000#
50	5.00" ID	D176014	1.75"	1.765"	6.00"	1.25"	1.38"	50,000#
55	5.50" ID	D177014	1.75"	1.765"	7.00"	1.25"	1.38"	57,500#
55	5.50" ID	D207015	2.00"	2.062"	7.00"	1.38"	1.50"	57,500#
60	6.00" ID	D207015	2.00"	2.062"	7.00"	1.38"	1.50"	75,000#
70	7.00" ID	D258217	2.50"	2.515"	8.25"	1.62"	1.75"	110,000#
80	8.00" ID	D309220	3.00"	3.015"	9.25"	1.88"	2.00"	140,000#

* Max Pull Yield is based on a 2:1 safety factor

Body Mount Code Description = D 10 30 09
 = Code Pin Size Width Radius

Note: 1/8" grease fitting located at 0 / 360 degrees unless otherwise specified

Note: Other mounts sizes available.

Note: Mounts also available with optional bushings.

Body / Main Barrel Mount Code

"C" Body Mount Code, Lug Body Mounts

Some sizes dimensionally interchangeable with NFPA Style MP3

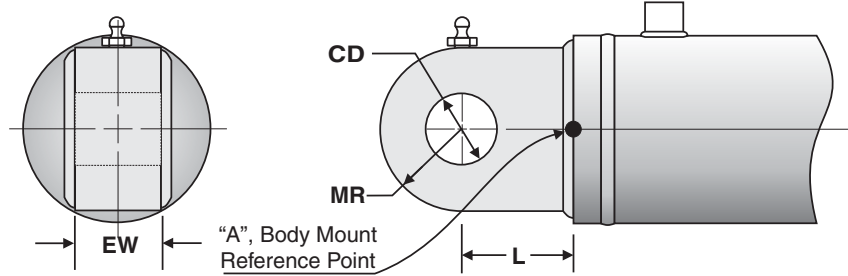

Body Code	Bore	Body Mount Code	Nominal Pin Size	Actual CD	Width EW	Length L	Radius MR	Max Pull at Yield *
20	2.00" ID	C101020	1.00"	1.015"	1.00"	2.00"	1.00"	25,000#
20	2.00" ID	C101220	1.00"	1.015"	1.25"	2.00"	1.00"	25,000#
25	2.50" ID	C101020	1.00"	1.015"	1.00"	2.00"	1.00"	25,000#
25	2.50" ID	C101220	1.00"	1.015"	1.25"	2.00"	1.00"	25,000#
30	3.00" ID	C101020	1.00"	1.015"	1.00"	2.00"	1.00"	25,000#
30	3.00" ID	C101220	1.00"	1.015"	1.25"	2.00"	1.00"	25,000#
32	3.25" ID	C121525	1.25"	1.265"	1.50"	2.50"	1.25"	30,000#
32	3.25" ID	C122025	1.25"	1.265"	2.00"	2.50"	1.25"	30,000#
35	3.50" ID	C121525	1.25"	1.265"	1.50"	2.50"	1.25"	30,000#
35	3.50" ID	C122025	1.25"	1.265"	2.00"	2.50"	1.25"	30,000#
40	4.00" ID	C121525	1.25"	1.265"	1.50"	2.50"	1.25"	37,500#
40	4.00" ID	C122025	1.25"	1.265"	2.00"	2.50"	1.25"	40,000#
45	4.50" ID	C121525	1.25"	1.265"	1.50"	2.50"	1.25"	45,000#
45	4.50" ID	C122025	1.25"	1.265"	2.00"	2.50"	1.25"	50,000#
50	5.00" ID	C152025	1.50"	1.515"	2.00"	2.50"	1.25"	50,000#
50	5.00" ID	C152525	1.50"	1.515"	2.50"	2.50"	1.25"	55,000#
50	5.00" ID	C202530	2.00"	2.015"	2.00"	2.50"	1.25"	25,000#
55	5.50" ID	C202030	2.00"	2.015"	2.00"	2.50"	1.25"	95,000#
55	5.50" ID	C202530	2.00"	2.015"	2.50"	3.00"	2.00"	72,000#
60	6.00" ID	C202030	2.00"	2.015"	2.00"	3.00"	2.00"	95,000#
60	6.00" ID	C202530	2.00"	2.015"	2.50"	3.00"	2.00"	95,000#
70	7.00" ID	C202030	2.00"	2.015"	2.00"	3.00"	2.00"	95,000#
70	7.00" ID	C202530	2.00"	2.015"	2.50"	3.00"	2.00"	120,000#
80	8.00" ID	C202030	2.00"	2.015"	2.00"	3.00"	2.00"	95,000#
80	8.00" ID	C202530	2.00"	2.015"	2.50"	3.00"	2.00"	120,000#
80	8.00" ID	C253534	2.50"	2.515"	3.50"	3.38"	3.00"	175,000#

* Max Pull Yield is based on a 2:1 safety factor

Body Mount Code Description = C 10 10 20
 Code Pin Size Width Length

Note: 1/8" grease fitting located at 0 / 360 degrees unless otherwise specified

Note: Other mounts sizes available.

Note: Mounts also available with optional bushings.

Body / Main Barrel Mount Code

"SN" Body Mount Code, Spherical Bearing Body Mounts

Some sizes dimensionally interchangeable with NFPA Style MP5

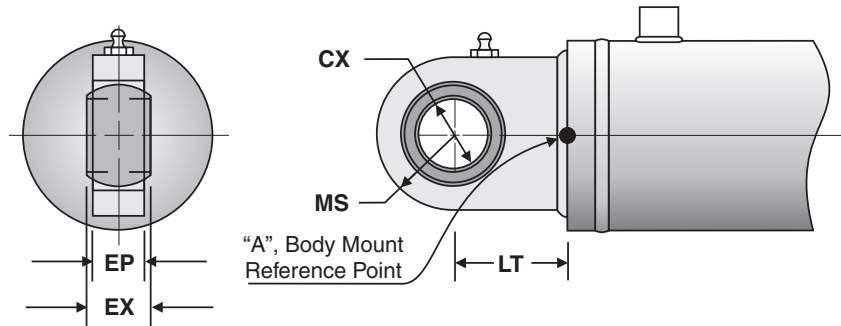

Body Code	Bore	Body Mount Code	Nominal Pin Size	Actual CX	Bearing Width EX	Lug Width EP	Length LT	Radius MS	Max Pull at Yield
20	2.00" ID	SN100720	1.00"	1.00"	0.88"	0.75"	2.00"	1.25"	15,000#
25	2.50" ID	SN100720	1.00"	1.00"	0.88"	0.75"	2.00"	1.25"	15,000#
30	3.00" ID	SN100720	1.00"	1.00"	0.88"	0.75"	2.00"	1.25"	15,000#
30	3.00" ID	SN120920	1.25"	1.25"	1.09"	0.94"	2.00"	1.50"	20,000#
30	3.00" ID	SN151125	1.50"	1.50"	1.31"	1.12"	2.50"	1.88"	35,000#
32	3.25" ID	SN120920	1.25"	1.25"	1.09"	0.94"	2.00"	1.50"	20,000#
32	3.25" ID	SN151125	1.50"	1.50"	1.31"	1.12"	2.50"	1.88"	35,000#
35	3.50" ID	SN120920	1.25"	1.25"	1.09"	0.94"	2.00"	1.50"	20,000#
35	3.50" ID	SN151125	1.50"	1.50"	1.31"	1.12"	2.50"	1.88"	35,000#
40	4.00" ID	SN151125	1.50"	1.50"	1.31"	1.12"	2.50"	1.88"	35,000#
40	4.00" ID	SN171325	1.75"	1.75"	1.53"	1.31"	2.50"	2.00"	35,000#
40	4.00" ID	SN201525	2.00"	2.00"	1.75"	1.50"	2.50"	2.38"	55,000#
45	4.50" ID	SN151125	1.50"	1.50"	1.31"	1.12"	2.50"	1.88"	35,000#
45	4.50" ID	SN171325	1.75"	1.75"	1.53"	1.31"	2.50"	2.00"	35,000#
45	4.50" ID	SN201525	2.00"	2.00"	1.75"	1.50"	2.50"	2.38"	55,000#
50	5.00" ID	SN171325	1.75"	1.75"	1.53"	1.31"	2.50"	2.00"	35,000#
50	5.00" ID	SN201525	2.00"	2.00"	1.75"	1.50"	2.50"	2.38"	55,000#
50	5.00" ID	SN251932	2.50"	2.50"	2.19"	1.88"	3.25"	3.00"	95,000#
55	5.50" ID	SN171325	1.75"	1.75"	1.53"	1.31"	2.50"	2.00"	35,000#
55	5.50" ID	SN201525	2.00"	2.00"	1.75"	1.50"	2.50"	2.38"	55,000#
55	5.50" ID	SN251932	2.50"	2.50"	2.19"	1.88"	3.25"	3.00"	95,000#
60	6.00" ID	SN171325	1.75"	1.75"	1.53"	1.31"	2.50"	2.00"	35,000#
60	6.00" ID	SN201525	2.00"	2.00"	1.75"	1.50"	2.50"	2.38"	55,000#
60	6.00" ID	SN251932	2.50"	2.50"	2.19"	1.88"	3.25"	3.00"	95,000#
70	7.00" ID	SN251932	2.50"	2.50"	2.19"	1.88"	3.25"	3.00"	95,000#
70	7.00" ID	SN302242	3.00"	3.00"	2.62"	2.25"	4.25"	3.75"	120,000#
80	8.00" ID	SN302242	3.00"	3.00"	2.62"	2.25"	4.25"	3.75"	120,000#

* Max Pull Yield is based on a 2:1 safety factor

Body Mount Code Description = $\frac{SN}{Code} \frac{10}{Pin\ Size} \frac{10}{Width} \frac{20}{Length}$

Note: 1/8" grease fitting located at 0 / 360 degrees unless otherwise specified

Note: Other mounts sizes available.

Body / Main Barrel Mount Code

Other mounting options available upon request:
Please contact sales office for availability.

"B" Body Mount Code, Drill Thru B Body Mounts

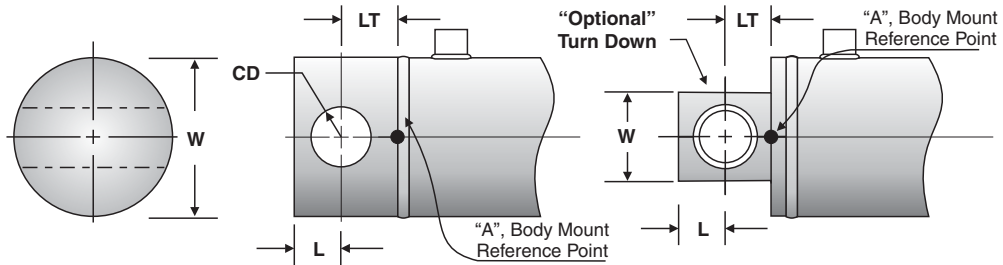

"M" Body Mount Code, Trunnion Body Mounts

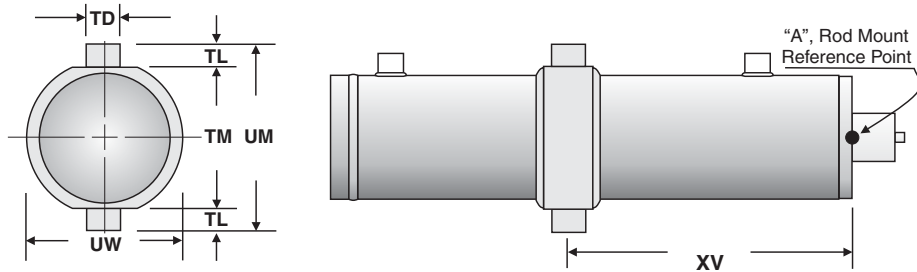

"E" Body Mount Code, Male Thread Body Mounts

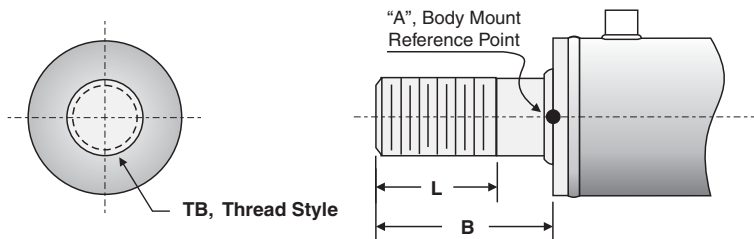

Body / Main Barrel Mount Code

Other mounting options available upon request:

Please contact sales office for availability.

"SW" Body Mount Code, Wide Spherical Bearing Body Mounts

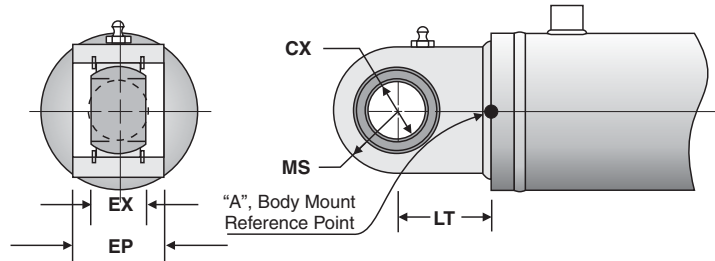

"G" Body Mount Code, Flange Body Mounts



"H" Body Mount Code, Flange Body Mounts

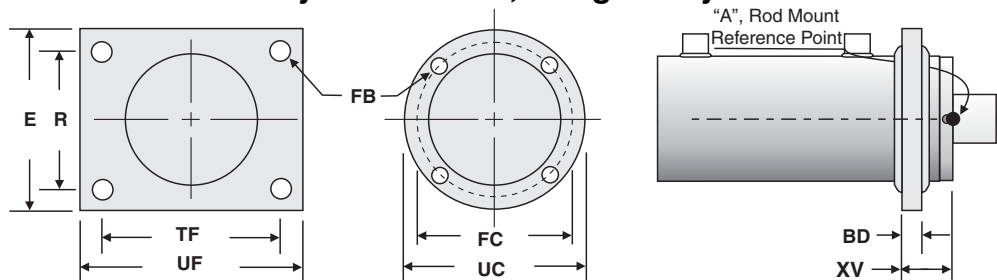

"A" Rod Mount Code, No Rod Mounts

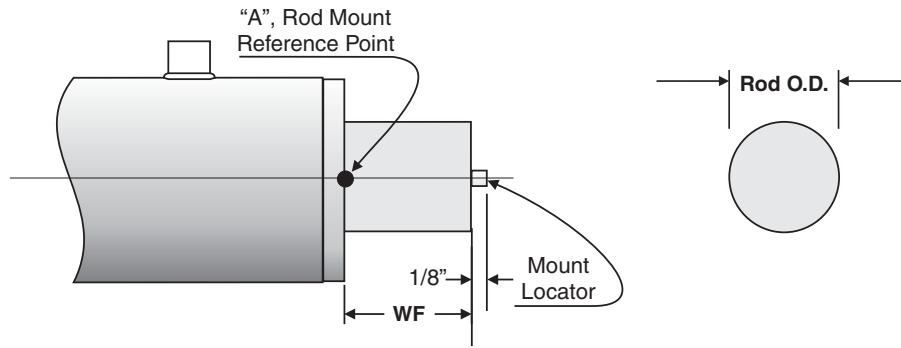

Rod Code	Rod Diameter	Rod Mount Code	Standard Rod Ext. WF
10	1.00" OD	A000000	0.88"
11	1.12" OD	A000000	0.88"
12	1.25" OD	A000000	0.88"
13	1.38" OD	A000000	0.88"
15	1.50" OD	A000000	0.88"
17	1.75" OD	A000000	0.88"
20	2.00" OD	A000000	0.88"
25	2.50" OD	A000000	0.88"
30	3.00" OD	A000000	0.88"
35	3.50" OD	A000000	0.88"
40	4.00" OD	A000000	0.88"
45	4.50" OD	A000000	0.88"

Rod End Mount Code

"L" Rod Mount Code, Clevis (Double Lug) Rod Mounts

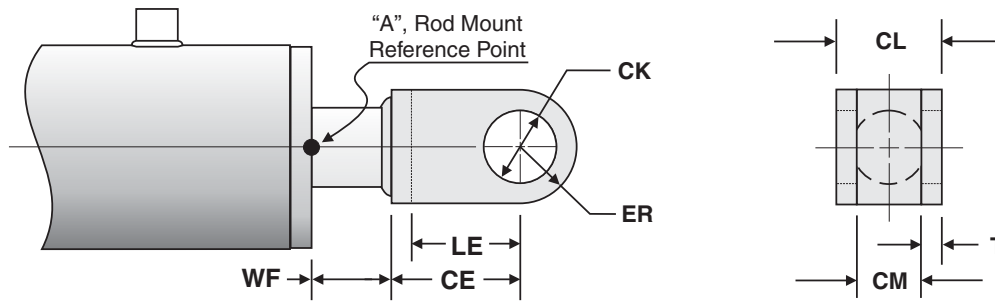

Rod Code	Rod Diameter	Rod Mount Code	Nominal Pin Size	Actual CK	Gap CM	Thickness T	Width CL	Radius ER	Length LE	Length CE	Rod Ext. WF	Max Pull at Yield *
10	1.00" OD	L101205	1.00"	1.015"	1.28"	0.50"	2.28"	1.00"	2.00"	2.50"	0.88"	16,500#
11	1.12" OD	L101205	1.00"	1.015"	1.28"	0.50"	2.28"	1.00"	2.00"	2.50"	0.88"	16,500#
12	1.25" OD	L101205	1.00"	1.015"	1.28"	0.50"	2.28"	1.00"	2.00"	2.50"	0.88"	25,000#
12	1.25" OD	L111205	1.12"	1.140"	1.28"	0.50"	2.28"	1.00"	2.00"	2.50"	0.88"	23,000#
13	1.38" OD	L101205	1.00"	1.015"	1.28"	0.50"	2.28"	1.00"	2.00"	2.50"	0.88"	25,000#
13	1.38" OD	L111205	1.12"	1.140"	1.28"	0.50"	2.28"	1.00"	2.00"	2.50"	0.88"	23,000#
15	1.50" OD	L101205	1.00"	1.015"	1.28"	0.50"	2.28"	1.00"	2.00"	2.50"	0.88"	25,000#
15	1.50" OD	L111205	1.12"	1.140"	1.28"	0.50"	2.28"	1.00"	2.00"	2.50"	0.88"	23,000#
17	1.75" OD	L101205	1.00"	1.015"	1.28"	0.50"	2.28"	1.00"	2.00"	2.50"	0.88"	25,000#
17	1.75" OD	L111205	1.12"	1.140"	1.28"	0.50"	2.28"	1.00"	2.00"	2.50"	0.88"	23,000#
17	1.75" OD	L121607	1.25"	1.265"	1.62"	0.75"	3.12"	1.25"	2.00"	2.75"	0.88"	50,000#
17	1.75" OD	L151610	1.50"	1.515"	1.62"	1.00"	3.62"	1.50"	2.00"	3.00"	0.88"	52,000#
20	2.00" OD	L101205	1.00"	1.015"	1.28"	0.50"	2.28"	1.00"	2.00"	2.50"	0.88"	25,000#
20	2.00" OD	L111205	1.12"	1.140"	1.28"	0.50"	2.28"	1.00"	2.00"	2.50"	0.88"	23,000#
20	2.00" OD	L121607	1.25"	1.265"	1.62"	0.75"	3.12"	1.25"	2.00"	2.75"	0.88"	50,000#
20	2.00" OD	L151610	1.50"	1.515"	1.62"	1.00"	3.62"	1.50"	2.00"	3.00"	0.88"	62,000#
20	2.00" OD	L152110	1.50"	1.515"	2.12"	1.00"	4.12"	1.50"	2.50"	3.50"	0.88"	62,000#
20	2.00" OD	L172110	1.75"	1.765"	2.12"	1.00"	4.12"	1.75"	2.25"	3.25"	0.88"	62,000#
25	2.50" OD	L101205	1.00"	1.015"	1.28"	0.50"	2.28"	1.00"	2.00"	2.50"	0.88"	25,000#
25	2.50" OD	L121607	1.25"	1.265"	1.62"	0.75"	3.12"	1.25"	2.00"	2.75"	0.88"	50,000#
25	2.50" OD	L151610	1.50"	1.515"	1.62"	1.00"	3.62"	1.50"	2.00"	3.00"	0.88"	80,000#
25	2.50" OD	L152110	1.50"	1.515"	2.12"	1.00"	4.12"	1.50"	2.50"	3.50"	0.88"	80,000#
25	2.50" OD	L172110	1.75"	1.765"	2.12"	1.00"	4.12"	1.75"	2.25"	3.25"	0.88"	93,000#
25	2.50" OD	L172112	1.75"	1.765"	2.12"	1.25"	4.62"	1.75"	2.25"	3.50"	0.88"	112,000#
25	2.50" OD	L202612	2.00"	2.015"	2.62"	1.25"	5.15"	2.00"	2.50"	3.75"	0.88"	134,000#
25	2.50" OD	L252612	2.50"	2.515"	2.62"	1.25"	5.12"	2.50"	3.00"	4.25"	0.88"	134,000#

* Max Pull Yield is based on a 2:1 safety factor

Rod Mount Code Description = L 07 12 06
 Code Pin Size Gap Thickness
 Note: Other mounts sizes available.
 Note: Mounts also available with optional bushings.

Rod End Mount Code

"L" Rod Mount Code, Clevis (Double Lug) Rod Mounts

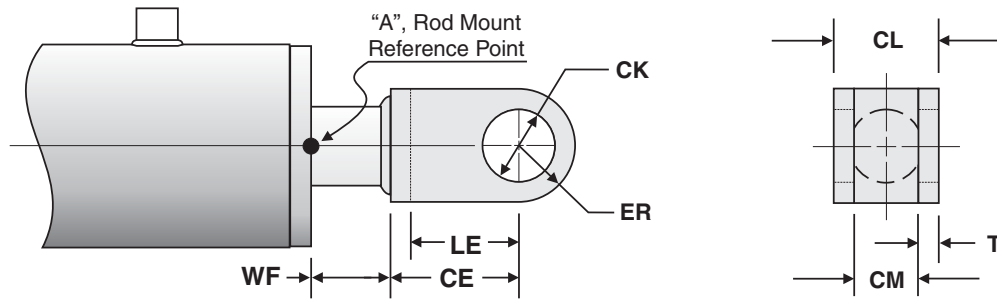

Rod Code	Rod Diameter	Rod Mount Code	Nominal Pin Size	Actual CK	Gap CM	Thickness T	Width CL	Radius ER	Length LE	Length CE	Rod Ext. WF	Max Pull at Yield *
30	3.00" OD	L151610	1.50"	1.515"	1.62"	1.00"	3.62"	1.50"	2.00"	3.00"	0.88"	80,000#
30	3.00" OD	L152110	1.50"	1.515"	2.12"	1.00"	4.12"	1.50"	2.50"	3.50"	0.88"	80,000#
30	3.00" OD	L172110	1.75"	1.765"	2.12"	1.00"	4.12"	1.75"	2.25"	3.25"	0.88"	93,000#
30	3.00" OD	L172112	1.75"	1.765"	2.12"	1.25"	4.62"	1.75"	2.25"	3.50"	0.88"	117,000#
30	3.00" OD	L202612	2.00"	2.015"	2.62"	1.25"	5.15"	2.00"	2.50"	3.75"	0.88"	128,000#
30	3.00" OD	L252612	2.50"	2.515"	2.62"	1.25"	5.12"	2.50"	3.00"	4.25"	0.88"	128,000#
35	3.50" OD	L172110	1.75"	1.765"	2.12"	1.00"	4.12"	1.75"	2.25"	3.25"	0.88"	93,000#
35	3.50" OD	L172112	1.75"	1.765"	2.12"	1.25"	4.62"	1.75"	2.25"	3.50"	0.88"	112,000#
35	3.50" OD	L202612	2.00"	2.015"	2.62"	1.25"	5.15"	2.00"	2.50"	3.75"	0.88"	134,000#
35	3.50" OD	L252612	2.50"	2.515"	2.62"	1.25"	5.12"	2.50"	3.00"	4.25"	0.88"	140,000#
35	3.50" OD	L303115	3.00"	3.015"	3.12"	1.50"	6.12"	3.00"	4.00"	5.50"	0.88"	140,000#
40	4.00" OD	L252612	2.50"	2.515"	2.62"	1.25"	5.12"	2.50"	3.00"	4.25"	0.88"	139,000#
40	4.00" OD	L303115	3.00"	3.015"	3.12"	1.50"	6.12"	3.00"	4.00"	5.50"	0.88"	139,000#
45	4.50" OD	L252612	2.50"	2.515"	2.62"	1.25"	5.12"	2.50"	3.00"	4.25"	0.88"	140,000#
45	4.50" OD	L303115	3.00"	3.015"	3.12"	1.50"	6.12"	3.00"	4.00"	5.50"	0.88"	140,000#

* Max Pull Yield is based on a 2:1 safety factor

Rod Mount Code Description = L Code Pin Size Gap Thickness
 Note: Other mounts sizes available.
 Note: Mounts also available with optional bushings.

Rod End Mount Code

"D" Rod Mount Code, Cross Tube Rod Mounts

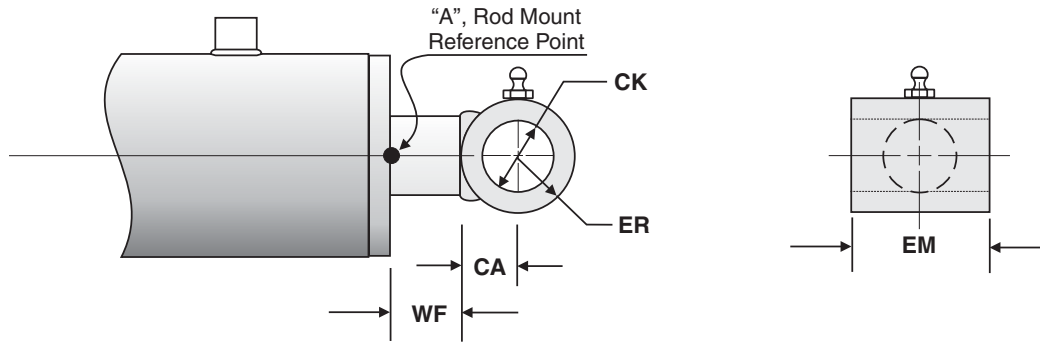

Rod Code	Rod Diameter	Rod Mount Code	Nominal Pin Size	Actual CK	Width EM	Length CA	Radius ER	Rod Ext. WF	Max Pull at Yield *
10	1.00" OD	D102509	1.00"	1.015"	2.50"	0.81"	0.88"	0.88"	16,500#
10	1.00" OD	D122510	1.25"	1.265"	2.50"	0.94"	1.00"	0.88"	16,500#
11	1.12" OD	D102509	1.00"	1.015"	2.50"	0.81"	0.88"	0.88"	16,500#
11	1.12" OD	D122510	1.25"	1.265"	2.50"	0.94"	1.00"	0.88"	16,500#
12	1.25" OD	D102509	1.00"	1.015"	2.50"	0.81"	0.88"	0.88"	27,600#
12	1.25" OD	D122510	1.25"	1.265"	2.50"	0.94"	1.00"	0.88"	27,600#
13	1.38" OD	D102509	1.00"	1.015"	2.50"	0.81"	0.88"	0.88"	35,300#
13	1.38" OD	D122510	1.25"	1.265"	2.50"	0.94"	1.00"	0.88"	35,300#
15	1.50" OD	D102509	1.00"	1.015"	2.50"	0.81"	0.88"	0.88"	32,500#
15	1.50" OD	D102709	1.00"	1.015"	2.75"	0.81"	0.88"	0.88"	32,500#
15	1.50" OD	D122510	1.25"	1.265"	2.50"	0.94"	1.00"	0.88"	32,500#
15	1.50" OD	D122710	1.25"	1.265"	2.75"	0.94"	1.00"	0.88"	32,500#
15	1.50" OD	D152711	1.50"	1.515"	2.75"	1.00"	1.12"	0.88"	32,500#
17	1.75" OD	D102509	1.00"	1.015"	2.50"	0.81"	0.88"	0.88"	42,300#
17	1.75" OD	D102709	1.00"	1.015"	2.75"	0.81"	0.88"	0.88"	42,300#
17	1.75" OD	D122710	1.25"	1.265"	2.75"	0.94"	1.00"	0.88"	42,300#
17	1.75" OD	D123210	1.25"	1.265"	3.25"	0.94"	1.00"	0.88"	42,300#
17	1.75" OD	D152711	1.50"	1.505"	2.75"	1.00"	1.12"	0.88"	42,300#
17	1.75" OD	D153011	1.50"	1.505"	3.00"	1.00"	1.12"	0.88"	42,300#
17	1.75" OD	D172514	1.75"	1.765"	2.50"	1.25"	1.38"	0.88"	42,300#
17	1.75" OD	D173014	1.75"	1.765"	3.00"	1.25"	1.38"	0.88"	42,300#
17	1.75" OD	D173214	1.75"	1.765"	3.25"	1.25"	1.38"	0.88"	42,300#
17	1.75" OD	D203515	2.00"	2.015"	3.50"	1.38"	1.50"	0.88"	42,300#
17	1.75" OD	D223515	2.25"	2.265"	3.50"	1.38"	1.50"	0.88"	42,300#
20	2.00" OD	D102509	1.00"	1.015"	2.50"	0.81"	0.88"	0.88"	49,700#
20	2.00" OD	D102709	1.00"	1.015"	2.75"	0.81"	0.88"	0.88"	49,700#
20	2.00" OD	D122710	1.25"	1.265"	2.75"	0.94"	1.00"	0.88"	49,700#
20	2.00" OD	D123210	1.25"	1.265"	3.25"	0.94"	1.00"	0.88"	49,700#
20	2.00" OD	D152711	1.50"	1.515"	2.75"	1.00"	1.12"	0.88"	49,700#
20	2.00" OD	D153011	1.50"	1.515"	3.00"	1.00"	1.12"	0.88"	49,700#
20	2.00" OD	D172514	1.75"	1.765"	2.50"	1.25"	1.38"	0.88"	49,700#
20	2.00" OD	D173014	1.75"	1.765"	3.00"	1.25"	1.38"	0.88"	49,700#
20	2.00" OD	D173214	1.75"	1.765"	3.25"	1.25"	1.38"	0.88"	49,700#
20	2.00" OD	D203515	2.00"	2.015"	3.50"	1.38"	1.50"	0.88"	49,700#
20	2.00" OD	D223515	2.25"	2.265"	3.50"	1.38"	1.50"	0.88"	49,700#

* Max Pull Yield is based on a 2:1 safety factor

Rod End Mount Code

"D" Rod Mount Code, Cross Tube Rod Mounts

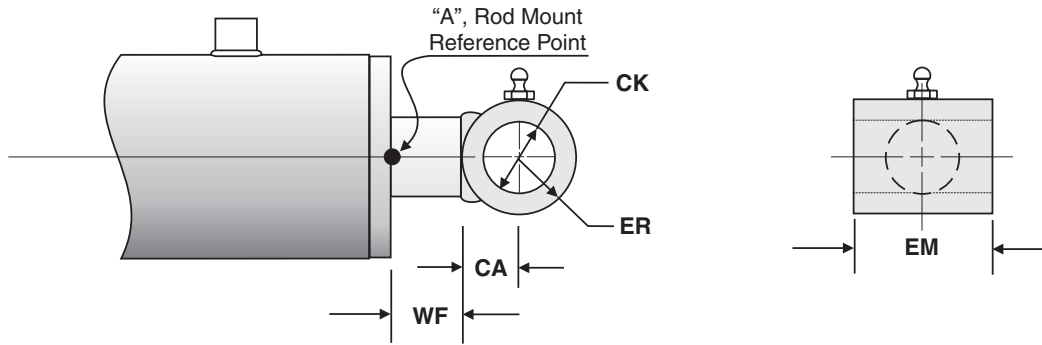

Rod Code	Rod Diameter	Rod Mount Code	Nominal Pin Size	Actual CK	Width EM	Length CA	Radius ER	Rod Ext. WF	Max Pull at Yield *
25	2.50" OD	D122710	1.25"	1.265"	2.75"	0.94"	1.00"	0.88"	71,000#
25	2.50" OD	D152711	1.50"	1.515"	2.75"	1.00"	1.12"	0.88"	102,000#
25	2.50" OD	D153011	1.50"	1.515"	3.00"	1.00"	1.12"	0.88"	102,000#
25	2.50" OD	D173214	1.75"	1.765"	3.25"	1.25"	1.38"	0.88"	102,000#
25	2.50" OD	D203515	2.00"	2.015"	3.50"	1.38"	1.50"	0.88"	102,000#
25	2.50" OD	D225017	2.25"	2.265"	5.00"	1.69"	1.75"	0.88"	102,000#
25	2.50" OD	D255017	2.50"	2.515"	5.00"	1.62"	1.75"	0.88"	102,000#
30	3.00" OD	D154212	1.50"	1.515"	4.25"	1.12"	1.25"	0.88"	91,000#
30	3.00" OD	D174714	1.75"	1.765"	4.75"	1.25"	1.38"	0.88"	100,000
30	3.00" OD	D203515	2.00"	2.015"	3.50"	1.38"	1.50"	0.88"	100,000
30	3.00" OD	D225017	2.25"	2.265"	5.00"	1.69"	1.75"	0.88"	140,000#
30	3.00" OD	D255017	2.50"	2.504"	5.00"	1.62"	1.75"	0.88"	140,000#
30	3.00" OD	D275017	2.75"	2.765"	5.00"	1.62"	1.75"	0.88"	140,000#
35	3.50" OD	D154212	1.50"	1.515"	4.25"	1.12"	1.25"	0.88"	100,000#
35	3.50" OD	D174714	1.75"	1.765"	4.75"	1.25"	1.38"	0.88"	128,000#
35	3.50" OD	D204715	2.00"	2.015"	4.75"	1.38"	1.50"	0.88"	128,000#
35	3.50" OD	D225016	2.25"	2.265"	5.00"	1.56"	1.62"	0.88"	140,000#
35	3.50" OD	D255017	2.50"	2.515"	5.00"	1.62"	1.75"	0.88"	140,000#
35	3.50" OD	D275020	2.75"	2.765"	5.00"	1.81"	2.00"	0.88"	140,000#
35	3.50" OD	D305020	3.00"	3.015"	5.00"	1.88"	2.00"	0.88"	140,000#
40	4.00" OD	D174714	1.75"	1.765"	4.75"	1.25"	1.38"	0.88"	128,000#
40	4.00" OD	D205015	2.00"	2.015"	5.00"	1.38"	1.50"	0.88"	128,000#
40	4.00" OD	D225016	2.25"	2.265"	5.00"	1.56"	1.62"	0.88"	140,000#
40	4.00" OD	D255017	2.50"	2.515"	5.00"	1.62"	1.75"	0.88"	140,000#
40	4.00" OD	D275020	2.75"	2.765"	5.00"	1.81"	2.00"	0.88"	140,000#
40	4.00" OD	D305020	3.00"	3.015"	5.00"	1.88"	2.00"	0.88"	140,000#
45	4.50" OD	D175014	1.75"	1.765"	5.00"	1.25"	1.38"	0.88"	128,000#
45	4.50" OD	D205015	2.00"	2.015"	5.00"	1.38"	1.50"	0.88"	128,000#
45	4.50" OD	D225016	2.25"	2.265"	5.00"	1.56"	1.62"	0.88"	140,000#
45	4.50" OD	D255017	2.50"	2.515"	5.00"	1.62"	1.75"	0.88"	140,000#
45	4.50" OD	D275020	2.75"	2.765"	5.00"	1.81"	2.00"	0.88"	140,000#
45	4.50" OD	D305020	3.00"	3.015"	5.00"	1.88"	2.00"	0.88"	140,000#

* Max Pull Yield is based on a 2:1 safety factor

Rod Mount Code Description = D 10 30 09
 Code Pin Size Width Radius
 Note: Other mounts sizes available.
 Note: Mounts also available with optional bushings.

Rod End Mount Code

"C" Rod Mount Code, Lug Rod Mounts

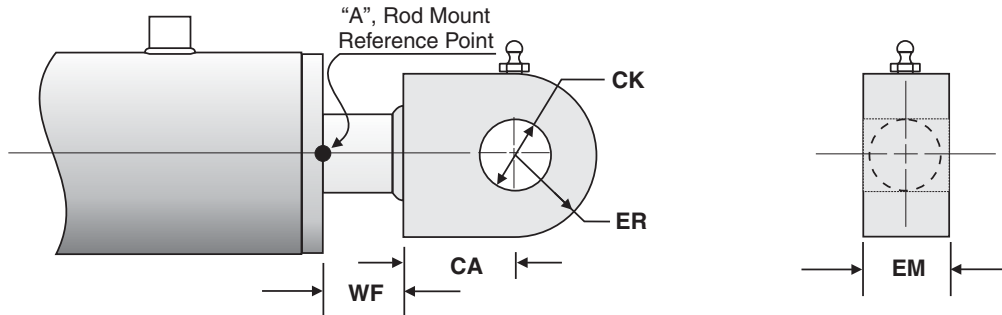

Rod Code	Rod Diameter	Rod Mount Code	Nominal Pin Size	Actual CK	Width EM	Lenght CA	Radius ER	Rod Ext. WF	Max Pull at Yield *
10	1.00" OD	C071015	0.75"	0.765"	1.00"	1.50"	0.75"	0.88"	13,000#
10	1.00" OD	C101020	1.00"	1.015"	1.00"	2.00"	1.00"	0.88"	15,000#
11	1.12" OD	C101220	1.00"	1.015"	1.25"	2.00"	1.00"	0.88"	16,500#
11	1.12" OD	C121520	1.25"	1.265"	1.50"	2.00"	1.25"	0.88"	16,500#
12	1.25" OD	C101220	1.00"	1.015"	1.25"	2.00"	1.00"	0.88"	30,000#
12	1.25" OD	C121520	1.25"	1.265"	1.50"	2.00"	1.25"	0.88"	30,000#
13	1.38" OD	C101520	1.00"	1.015"	1.50"	2.00"	1.00"	0.88"	35,000#
13	1.38" OD	C121520	1.25"	1.265"	1.50"	2.00"	1.25"	0.88"	33,000#
13	1.38" OD	C151520	1.50"	1.515"	1.50"	2.00"	1.50"	0.88"	40,000#
15	1.50" OD	C101220	1.00"	1.015"	1.25"	2.00"	1.00"	0.88"	30,000#
15	1.50" OD	C101520	1.00"	1.015"	1.50"	2.00"	1.00"	0.88"	35,000#
15	1.50" OD	C121520	1.25"	1.265"	1.50"	2.00"	1.25"	0.88"	30,000#
15	1.50" OD	C151520	1.50"	1.515"	1.50"	2.00"	1.50"	0.88"	40,000#
15	1.50" OD	C171525	1.75"	1.765"	1.50"	2.50"	1.75"	0.88"	40,000#
17	1.75" OD	C101720	1.00"	1.015"	1.75"	2.00"	1.00"	0.88"	40,000#
17	1.75" OD	C121720	1.25"	1.265"	1.75"	2.00"	1.25"	0.88"	50,000#
17	1.75" OD	C151725	1.50"	1.515"	1.75"	2.50"	1.50"	0.88"	45,000#
17	1.75" OD	C171725	1.75"	1.765"	1.75"	2.50"	1.75"	0.88"	50,000#
20	2.00" OD	C102020	1.00"	1.015"	2.00"	2.00"	1.00"	0.88"	50,000#
20	2.00" OD	C122020	1.25"	1.265"	2.00"	2.00"	1.25"	0.88"	60,000#
20	2.00" OD	C152025	1.50"	1.515"	2.00"	2.50"	1.50"	0.88"	50,000#
20	2.00" OD	C152525	1.50"	1.515"	2.50"	2.50"	1.50"	0.88"	60,000#
20	2.00" OD	C172025	1.75"	1.765"	2.00"	2.50"	1.75"	0.88"	60,000#
20	2.00" OD	C172525	1.75"	1.765"	2.50"	2.50"	1.75"	0.88"	60,000#
20	2.00" OD	C202025	2.00"	2.015"	2.00"	2.50"	2.00"	0.88"	60,000#
20	2.00" OD	C202525	2.00"	2.015"	2.50"	2.50"	2.00"	0.88"	60,000#
20	2.00" OD	C222025	2.25"	2.265"	2.00"	2.50"	2.25"	0.88"	60,000#
20	2.00" OD	C222525	2.25"	2.265"	2.50"	2.50"	2.25"	0.88"	60,000#
20	2.00" OD	C252027	2.50"	2.515"	2.00"	2.75"	2.50"	0.88"	60,000#
20	2.00" OD	C252527	2.50"	2.515"	2.50"	2.75"	2.50"	0.88"	60,000#
20	2.00" OD	C302030	3.00"	3.067"	2.00"	3.00"	3.00"	0.88"	60,000#
20	2.00" OD	C302530	3.00"	3.067"	2.50"	3.00"	3.00"	0.88"	60,000#

* Max Pull Yield is based on a 2:1 safety factor

Rod Mount Code Description = C Pin Size Width Length

Note: Other mounts sizes available.

Note: Mounts also available with optional bushings.

Rod End Mount Code

"C" Rod Mount Code, Lug Rod Mounts

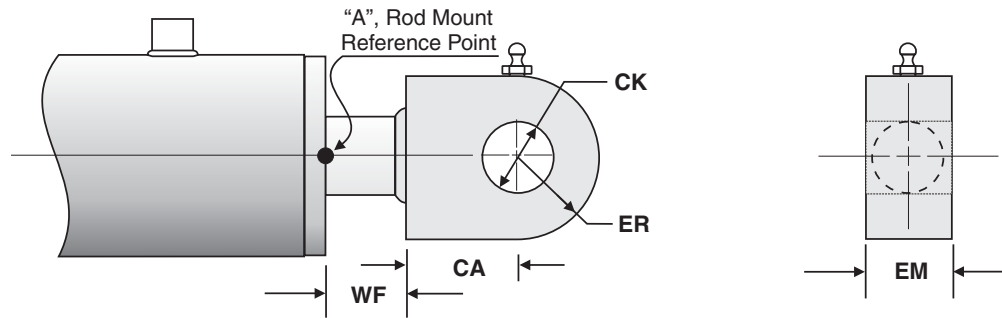

Rod Code	Rod Diameter	Rod Mount Code	Nominal Pin Size	Actual CK	Width EM	Length CA	Radius ER	Rod Ext. WF	Max Pull at Yield *
25	2.50" OD	C122520	1.25"	1.265"	2.50"	2.00"	1.25"	0.88"	75,000#
25	2.50" OD	C152525	1.50"	1.515"	2.50"	2.50"	1.50"	0.88"	93,000#
25	2.50" OD	C172525	1.75"	1.765"	2.50"	2.50"	1.75"	0.88"	105,000#
25	2.50" OD	C173025	1.75"	1.765"	3.00"	2.50"	1.75"	0.88"	93,000#
25	2.50" OD	C202525	2.00"	2.015"	2.50"	2.50"	2.00"	0.88"	120,000#
25	2.50" OD	C203025	2.00"	2.015"	3.00"	2.50"	2.00"	0.88"	105,000#
25	2.50" OD	C222525	2.25"	2.265"	2.50"	2.50"	2.25"	0.88"	100,000#
25	2.50" OD	C223025	2.25"	2.265"	3.00"	2.50"	2.25"	0.88"	120,000#
25	2.50" OD	C252527	2.50"	2.515"	2.50"	2.75"	2.50"	0.88"	110,000#
25	2.50" OD	C302730	3.00"	3.062"	2.75"	3.00"	3.00"	0.88"	130,000#
30	3.00" OD	C153025	1.50"	1.515"	3.00"	2.50"	1.25"	0.88"	70,000#
30	3.00" OD	C202025	2.00"	2.015"	2.00"	2.50"	2.00"	0.88"	95,000#
30	3.00" OD	C203025	2.00"	2.015"	3.00"	2.50"	2.00"	0.88"	105,000#
30	3.00" OD	C223025	2.25"	2.265"	3.00"	2.50"	2.25"	0.88"	120,000#
30	3.00" OD	C253027	2.50"	2.515"	3.00"	2.75"	2.50"	0.88"	130,000#
30	3.00" OD	C303030	3.00"	3.062"	3.00"	3.00"	3.00"	0.88"	130,000#
35	3.50" OD	C202025	2.00"	2.015"	2.00"	2.50"	2.00"	0.88"	95,000#
35	3.50" OD	C223025	2.25"	2.260"	3.00"	2.50"	2.25"	0.88"	120,000#
35	3.50" OD	C253027	2.50"	2.515"	3.00"	2.75"	2.50"	0.88"	130,000#
35	3.50" OD	C303030	3.00"	3.062"	3.00"	3.00"	3.00"	0.88"	140,000#
40	4.00" OD	C202025	2.00"	2.015"	2.00"	2.50"	2.00"	0.88"	95,000#
40	4.00" OD	C253027	2.50"	2.565"	3.00"	2.75"	2.50"	0.88"	130,000#
40	4.00" OD	C303030	3.00"	3.062"	3.00"	3.00"	3.00"	0.88"	140,000#
45	4.50" OD	C202025	2.00"	2.015"	2.00"	2.50"	2.00"	0.88"	95,000#
45	4.50" OD	C253027	2.50"	2.565"	3.00"	2.75"	2.50"	0.88"	130,000#
45	4.50" OD	C303030	3.00"	3.015"	3.00"	3.00"	3.00"	0.88"	140,000#

* Max Pull Yield is based on a 2:1 safety factor

Rod Mount Code Description = $\frac{C}{Code} \frac{10}{Pin\ Size} \frac{10}{Width} \frac{20}{Length}$
 Note: Other mounts sizes available.
 Note: Mounts also available with optional bushings.

Rod End Mount Code

"SN" Rod Mount Code, Spherical Bearing Narrow Rod Mounts

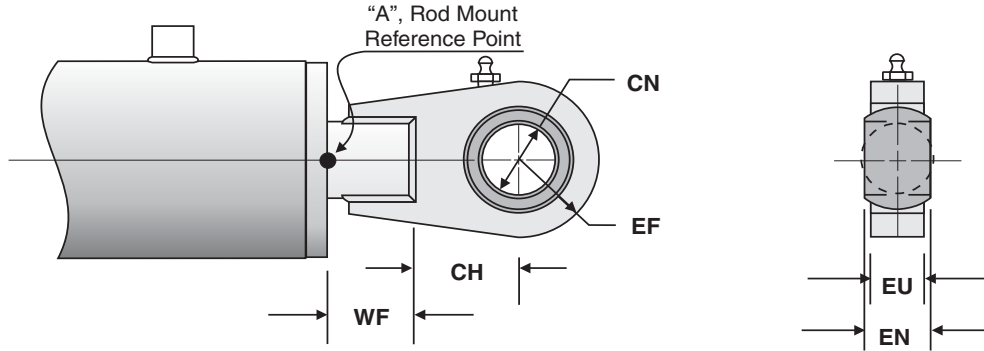

Rod Code	Rod Diameter	Rod Mount Code	Nominal Pin Size	Actual CN	Bearing Width EN	Lug Width EU	Length CH	Length L1	Radius EF	Rod Ext. WF	Max Pull at Yield
10	1.00" OD	SN100721	1.00"	1.00"	0.88"	0.75"	2.12"	2.75"	1.25"	1.38"	15,000#
11	1.12" OD	SN100721	1.00"	1.00"	0.88"	0.75"	2.12"	2.75"	1.25"	1.38"	15,000#
12	1.25" OD	SN100721	1.00"	1.00"	0.88"	0.75"	2.12"	2.75"	1.25"	1.38"	15,000#
12	1.25" OD	SN120922	1.25"	1.25"	1.09"	0.94"	2.25"	3.00"	1.50"	1.62"	20,000#
13	1.38" OD	SN120922	1.25"	1.25"	1.09"	0.94"	2.25"	3.00"	1.50"	1.62"	20,000#
15	1.50" OD	SN151125	1.50"	1.50"	1.31"	1.12"	2.50"	3.25"	1.88"	1.62"	35,000#
17	1.75" OD	SN120922	1.25"	1.25"	1.09"	0.94"	2.25"	3.00"	1.50"	1.62"	20,000#
17	1.75" OD	SN151125	1.50"	1.50"	1.31"	1.12"	2.50"	3.25"	1.88"	1.62"	35,000#
17	1.75" OD	SN171327	1.75"	1.75"	1.53"	1.31"	2.75"	3.75"	2.00"	1.88"	35,000#
20	2.00" OD	SN120922	1.25"	1.25"	1.09"	0.94"	2.25"	3.00"	1.50"	1.62"	20,000#
20	2.00" OD	SN151125	1.50"	1.50"	1.31"	1.12"	2.50"	3.25"	1.88"	1.88"	35,000#
20	2.00" OD	SN171327	1.75"	1.75"	1.53"	1.31"	2.75"	3.75"	2.00"	1.88"	35,000#
20	2.00" OD	SN201530	2.00"	2.00"	1.75"	1.50"	3.00"	4.00"	2.38"	1.88"	55,000#
25	2.50" OD	SN151125	1.50"	1.50"	1.31"	1.12"	2.50"	3.25"	1.88"	1.62"	35,000#
25	2.50" OD	SN171327	1.75"	1.75"	1.53"	1.31"	2.75"	3.75"	2.00"	1.88"	35,000#
25	2.50" OD	SN201530	2.00"	2.00"	1.75"	1.50"	3.00"	4.00"	2.38"	1.88"	55,000#
25	2.50" OD	SN251935	2.50"	2.50"	2.19"	1.88"	3.50"	4.75"	3.00"	2.12"	95,000#
30	3.00" OD	SN151125	1.50"	1.50"	1.31"	1.12"	2.50"	3.25"	1.88"	1.62"	35,000#
30	3.00" OD	SN171327	1.75"	1.75"	1.53"	1.31"	2.75"	3.75"	2.00"	1.88"	35,000#
30	3.00" OD	SN201530	2.00"	2.00"	1.75"	1.50"	3.00"	4.00"	2.38"	1.88"	55,000#
30	3.00" OD	SN251935	2.50"	2.50"	2.19"	1.88"	3.50"	4.75"	3.00"	2.12"	95,000#
35	3.50" OD	SN151125	1.50"	1.50"	1.31"	1.12"	2.50"	3.25"	1.88"	1.62"	35,000#
35	3.50" OD	SN171327	1.75"	1.75"	1.53"	1.31"	2.75"	3.75"	2.00"	1.88"	35,000#
35	3.50" OD	SN201530	2.00"	2.00"	1.75"	1.50"	3.00"	4.00"	2.38"	1.88"	55,000#
35	3.50" OD	SN251935	2.50"	2.50"	2.19"	1.88"	3.50"	4.75"	3.00"	2.12"	95,000#
40	4.00" OD	SN171327	1.75"	1.75"	1.53"	1.31"	2.75"	3.75"	2.00"	1.88"	35,000#
40	4.00" OD	SN201530	2.00"	2.00"	1.75"	1.50"	3.00"	4.00"	2.38"	1.88"	55,000#
40	4.00" OD	SN251935	2.50"	2.50"	2.19"	1.88"	3.50"	4.75"	3.00"	2.12"	95,000#
40	4.00" OD	SN302242	3.00"	3.00"	2.62"	2.25"	4.25"	5.50"	3.75"	2.12"	120,000#
45	4.50" OD	SN251935	2.50"	2.50"	2.19"	1.88"	3.50"	4.75"	3.00"	2.12"	95,000#
45	4.50" OD	SN302242	3.00"	3.00"	2.62"	2.25"	4.25"	5.50"	3.75"	2.12"	120,000#

* Max Pull Yield is based on a 2:1 safety factor

Rob Mount SN 10 10 20
Code Description = Code Pin Size Width Length

Note: Other mounts sizes available.

Rod End Mount Code

"B" Rod Mount Code, Drill Thru Rod Mounts

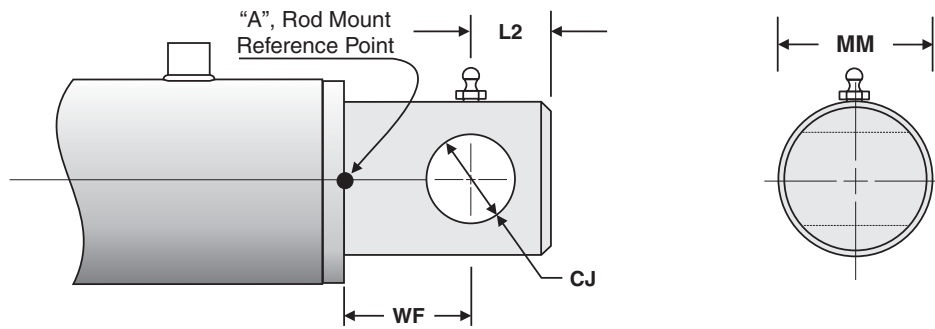

Rod Code	Rod Diameter	Rod Mount Code	Nominal Pin Size	Actual CJ	Diameter MM	Length WF	Length L2	Max Pull at Yield *
10	1.00" OD	B051600	0.50"	0.515"	1.00"	1.62"	0.75"	14,000#
11	1.12" OD	B051600	0.50"	0.515"	1.00"	1.62"	0.75"	16,500#
12	1.25" OD	B051600	0.50"	0.515"	1.00"	1.62"	0.75"	30,000#
12	1.25" OD	B071900	0.75"	0.760"	1.00"	1.88"	0.75"	17,000#
13	1.38" OD	B071900	0.75"	0.760"	1.38"	1.88"	0.75"	24,750#
15	1.50" OD	B071900	0.75"	0.760"	1.50"	1.88"	0.75"	33,800#
15	1.50" OD	B102100	1.00"	1.015"	1.50"	2.12"	1.00"	18,500#
17	1.75" OD	B071900	0.75"	0.760"	1.75"	1.88"	0.75"	55,900#
17	1.75" OD	B102100	1.00"	1.015"	1.75"	2.12"	1.00"	36,700#
20	2.00" OD	B071900	0.75"	0.760"	2.00"	1.88"	0.75"	77,000#
20	2.00" OD	B102100	1.00"	1.015"	2.00"	2.12"	1.00"	60,000#
20	2.00" OD	B122100	1.25"	1.265"	2.00"	2.12"	1.25"	39,500#
25	2.50" OD	B102100	1.00"	1.015"	2.50"	2.12"	1.00"	77,000#
25	2.50" OD	B122100	1.25"	1.265"	2.50"	2.12"	1.25"	77,000#
25	2.50" OD	B152400	1.50"	1.515"	2.50"	2.37"	1.50"	68,000#
30	3.00" OD	B102100	1.00"	1.015"	3.00"	2.12"	1.00"	140,000#
30	3.00" OD	B122100	1.25"	1.265"	3.00"	2.12"	1.25"	140,000#
30	3.00" OD	B152400	1.50"	1.515"	3.00"	2.37"	1.50"	140,000#
35	3.50" OD	B122100	1.25"	1.265"	3.50"	2.12"	1.25"	140,000#
35	3.50" OD	B152400	1.50"	1.515"	3.50"	2.37"	1.50"	140,000#
35	3.50" OD	B202600	2.00"	2.031"	3.50"	2.62"	2.00"	136,000#
40	4.00" OD	B122100	1.25"	1.265"	4.00"	2.12"	1.25"	140,000#
40	4.00" OD	B152400	1.50"	1.515"	4.00"	2.37"	1.50"	140,000#
40	4.00" OD	B202600	2.00"	2.031"	4.00"	2.62"	2.00"	140,000#
45	4.50" OD	B152400	1.50"	1.515"	4.50"	2.37"	1.50"	140,000#
45	4.50" OD	B202600	2.00"	2.031"	4.50"	2.62"	2.00"	140,000#
45	4.50" OD	B253100	2.50"	2.562"	4.50"	3.12"	2.50"	140,000#

* Max Pull Yield is based on a 2:1 safety factor

Rod Mount Code Description = **B** 10 21 00
 Code Pin Size Length Filler

Note: Other mounts sizes available.

Note: Mounts also available with optional bushings.

Rod End Mount Code

"N" Rod Mount Code, Female Thread Rod Mounts

Some sizes dimensionally interchangeable with NFPA Style SF

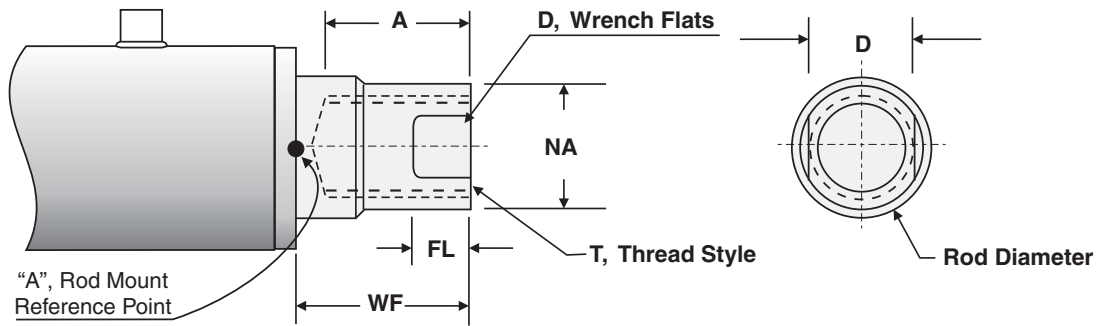

Rod Code	Rod Diameter	Rod Mount Code	Thread Style T	Length A	Wrench Flats FL	Wrench Flats D	End Rod NA	Rod Ext. WF	Max Pull at Yield *	NFPA Style
10	1.00" OD	N082017	1/2"-20	1.75"	0.38"	0.88"	NA	1.50"	16,500#	
10	1.00" OD	N121611	3/4"-16	1.12"	0.38"	0.88"	0.94"	1.50"	16,500#	SF
11	1.12" OD	N121611	3/4"-16	1.12"	0.38"	0.88"	1.06"	1.50"	16,500#	
12	1.25" OD	N121611	3/4"-16	1.12"	0.38"	0.88"	1.12"	1.50"	39,000#	
13	1.38" OD	N161416	1"-14	1.62"	0.62"	1.12"	1.31"	1.50"	35,000#	SF
15	1.50" OD	N121611	3/4"-16	1.12"	0.38"	0.88"	1.31"	1.50"	41,000#	
15	1.50" OD	N161416	1"-14	1.62"	0.62"	1.12"	1.31"	1.50"	41,000#	
17	1.75" OD	N201220	1-1/4"-12	2.00"	0.88"	1.50"	1.69"	1.75"	58,900#	SF
20	2.00" OD	N241222	1-1/2"-12	2.25"	0.75"	1.50"	1.94"	1.75"	68,700#	SF
25	2.50" OD	N301230	1-7/8"-12	3.00"	1.00"	2.06"	2.38"	2.00"	77,000#	SF
30	3.00" OD	N361235	2-1/4"-12	3.50"	1.00"	2.62"	2.88"	2.00"	102,000#	SF
35	3.50" OD	N401235	2-1/2"-12	3.50"	1.00"	3.00"	3.38"	2.00"	140,000#	SF
40	4.00" OD	N481240	3"-12	4.00"	1.00"	3.38"	3.88"	2.00"	140,000#	SF
45	4.50" OD	N521245	3-1/4"-12	4.50"	1.00"	4.00"	4.38"	2.00"	140,000#	SF

* Max Pull Yield is based on a 2:1 safety factor

Note: Usually, a female thread is recommended over a male thread because a broken end can be easily replaced as opposed to changing a rod that had a male thread. Also, a female thread can be converted to a male thread by using a rod stud (consult factory for rod stud options).

Rod Mount Code Description = $\frac{N}{Code} \frac{08}{Diameter} \frac{20}{Pitch} \frac{17}{Depth}$
 Note: Other mounts sizes available.

Rod End Mount Code

"E" Rod Mount Code, Male Thread Rod Mounts

Some sizes dimensionally interchangeable with NFPA Style IM & SM

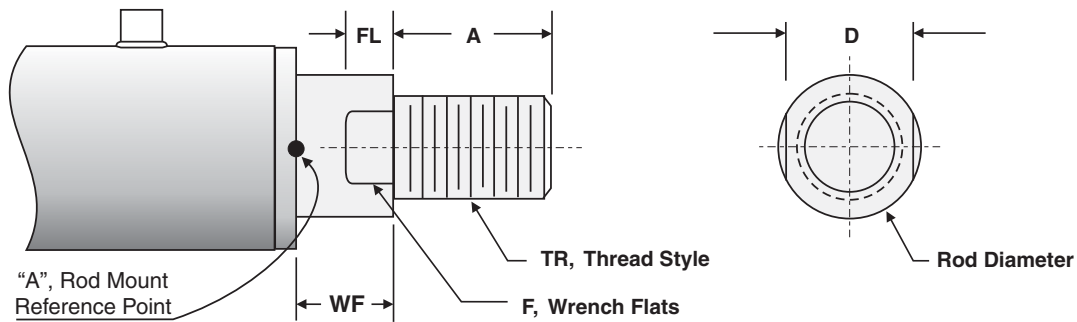

Rod Code	Rod Diameter	Rod Mount Code	Thread Style TR	Length A	Wrench Flats FL	Wrench Flats D	Rod Ext. WF	Max Pull at Yield *	NFPA Style
10	1.00" OD	E121612	3/4"-16	1.12"	0.50"	0.88"	1.00"	16,500#	SM
10	1.00" OD	E141416	7/8"-14	1.62"	0.50"	0.88"	1.00"	16,500#	IM
10	1.00" OD	E161416	1"-14	1.62"	0.62"	0.88"	1.12"	16,500#	
11	1.12" OD	E161416	1"-14	1.62"	0.62"	1.00"	1.12"	16,500#	
11	1.12" OD	E161220	1"-12	2.00"	0.31"	1.00"	0.81"	16,500#	
12	1.25" OD	E201216	1-1/4"-12	1.62"	0.62"	1.12"	1.12"	41,000#	
13	1.38" OD	E161416	1"-14	1.62"	0.62"	1.12"	1.12"	32,000#	SM
13	1.38" OD	E201216	1-1/4"-12	1.62"	0.62"	1.12"	1.12"	41,000#	IM
15	1.50" OD	E161416	1"-14	1.62"	0.62"	1.25"	1.12"	32,000#	
15	1.50" OD	E201216	1-1/4"-12	1.62"	0.62"	1.25"	1.12"	41,000#	
15	1.50" OD	E221212	1-3/8"-12	1.19"	0.43"	1.25"	0.94"	41,000#	
17	1.75" OD	E201220	1-1/4"-12	2.00"	0.75"	1.50"	1.25"	52,000#	SM
17	1.75" OD	E241220	1-1/2"-12	2.00"	0.75"	1.50"	1.25"	71,000#	IM
20	2.00" OD	E241222	1-1/2"-12	2.25"	0.88"	1.69"	1.38"	77,000#	SM
20	2.00" OD	E281222	1-3/4"-12	2.25"	0.88"	1.69"	1.38"	77,000#	IM
20	2.00" OD	E320832	2"-8	3.25"	0.75"	1.75"	1.25"	77,000#	
20	2.00" OD	E321228	2"-12	2.88"	1.00"	1.75"	1.50"	77,000#	
25	2.50" OD	E301230	1-7/8"-12	3.00"	1.00"	2.06"	1.50"	77,000#	SM
25	2.50" OD	E361230	2-1/4"-12	3.00"	1.00"	2.06"	1.50"	77,000#	IM
30	3.00" OD	E361235	2-1/4"-12	3.50"	1.00"	2.62"	1.50"	141,000#	SM
30	3.00" OD	E441235	2-3/4"-12	3.50"	1.00"	2.62"	1.50"	141,000#	IM
35	3.50" OD	E401235	2-1/2"-12	3.50"	1.00"	3.00"	1.50"	141,000#	SM
35	3.50" OD	E521235	3-1/4"-12	3.50"	1.00"	3.00"	1.50"	141,000#	IM
40	4.00" OD	E481240	3"-12	4.00"	1.00"	3.38"	1.50"	141,000#	SM
40	4.00" OD	E601240	3-3/4"-12	4.00"	1.00"	3.38"	1.50"	141,000#	IM
45	4.50" OD	E521245	3-1/4"-12	4.50"	1.00"	4.00"	1.50"	141,000#	SM

* Max Pull Yield is based on a 2:1 safety factor

Rod Mount Code Description = E 08 20 17
 = Code Diameter Pitch Depth

Note: Other mounts sizes available.

Rod End Mount Code

Other mounting options available upon request:

Please contact sales office for availability.

"SW" Rod Mount Code, Spherical Bearing Wide Rod Mounts

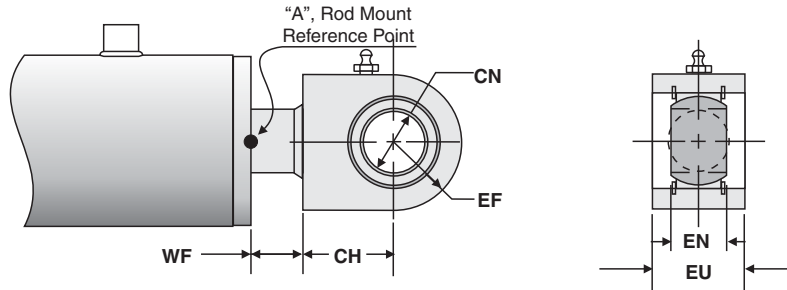

"Z" Rod Mount Code, Ball Type Rod Mounts

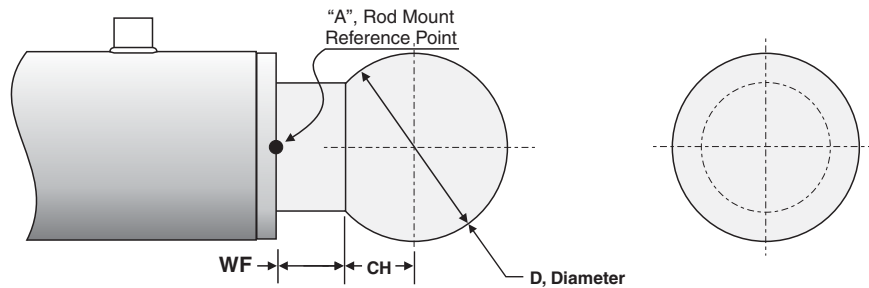

"F" Rod Mount Code, Drilled & Tapped 2 or More Holes Rod Mounts

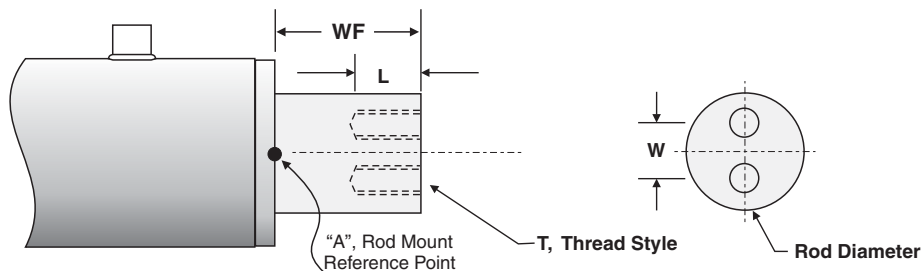

Rod Extension, Stop Tube and Ports

Rod Extension: (default is 0.000)

Enter amount of additional rod extension required in inches if other than the standard catalog "WF" dimension.

Example 3.250" Rod Extension

Note: This will effect over all Closed Length and Open Length by the additional Rod Extension, but will NOT affect the Stroke.

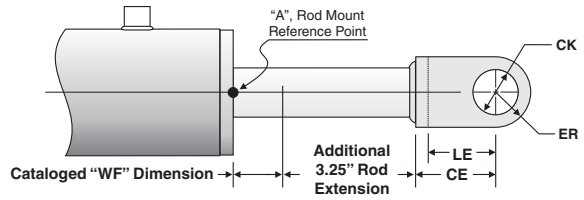

Stop Tube Length: (default is 0.000)

Enter length of stop tube required in inches, example 3.250".

Note: This will effect the over all Stroke and the Open dimensions, but will NOT affect the Closed length. (Example; "A" = 6.56" + Stroke of 20" = 26.56" Closed and 46.56" Open Length, add 3.250" Stop Tube 26.56" Closed remains the same but Open Length becomes 43.31".

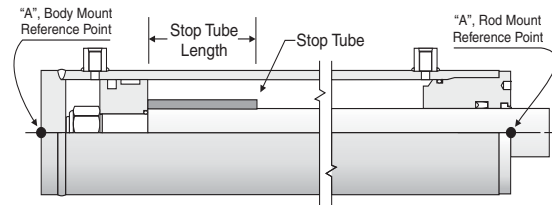

Port Code, Extend Cap Port and Retract Head Port:

Enter Port Code

Port Code	Port Size & Type	A	B	C	D	WMD Availability	WHD Availability
TS04	#4 SAE	0.63"	-	-	0.75"	2.00"-5.00"	N/A
TS06	#6 SAE	0.75"	-	-	1.00"	2.00"-5.00"	3.00"-5.50"
TS08	#8 SAE	0.81"	-	-	1.12"	2.00"-5.00"	3.00"-8.00"
TS10	#10 SAE	0.78"	-	-	1.25"	5.00"	3.00"-8.00"
TS12	#12 SAE	0.78"	-	-	1.50"	5.00"	3.00"-8.00"
TS16	#16 SAE	0.96"	-	-	2.00"	N/A	4.50"-8.00"
TS20	#20 SAE	0.88"	-	-	2.25"	N/A	8.00"
US04	1/4" NPT	0.69"	-	-	0.75"	2.00"-5.00"	N/A
US06	3/8" NPT	0.75"	-	-	1.25"	2.00"-5.00"	3.00"-5.50"
US08	1/2" NPT	0.88"	-	-	1.13"	2.00"-5.00"	3.00"-8.00"
US12	3/4" NPT	0.94"	-	-	1.38"	5.00"	3.00"-8.00"
US16	1" NPT	1.13"	-	-	1.75"	N/A	4.50"-8.00"
US20	1 1/4" NPT	1.19"	-	-	2.25"	N/A	8.00"

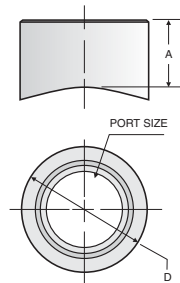

Port Code	Port Size & Type	A	B	C	D	WMD Availability	WHD Availability
TE04	#4 SAE Elbow	1.13"	0.75"	0.44"	1.13"	2.00"-5.00"	N/A
TE06	#6 SAE Elbow	1.25"	0.81"	0.50"	1.25"	2.00"-5.00"	3.00"-5.50"
TE08	#8 SAE Elbow	1.57"	0.95"	0.63"	1.63"	2.00"-5.00"	3.00"-8.00"
TE10	#10 SAE Elbow	1.81"	1.05"	0.69"	1.75"	5.00"	3.00"-8.00"
TE12	#12 SAE Elbow	1.93"	1.12"	0.81"	2.12"	5.00"	3.00"-8.00"
TE16	#16 SAE Elbow	2.31"	1.31"	0.81"	2.25"	N/A	4.50"-8.00"
TE20	#20 SAE Elbow	2.56"	1.56"	0.88"	2.63"	N/A	8.00"
UE04	1/4" NPT Elbow	1.03"	0.65"	0.41"	1.00"	2.00"-5.00"	N/A
UE06	3/8" NPT Elbow	1.20"	0.75"	0.50"	1.25"	2.00"-5.00"	3.00"-5.50"
UE08	1/2" NPT Elbow	1.57"	0.95"	0.69"	1.63"	2.00"-5.00"	3.00"-8.00"
UE12	3/4" NPT Elbow	1.94"	1.13"	0.81"	2.00"	5.00"	3.00"-8.00"
UE16	1" NPT Elbow	2.31"	1.31"	0.81"	2.25"	N/A	4.50"-8.00"
UE20	1 1/4" NPT Elbow	2.56"	1.56"	0.94"	2.63"	N/A	8.00"

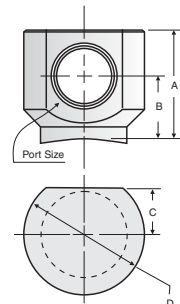

Note: Unless otherwise specified as a "SR" Option, 90-degree elbows the port will face the base of cylinder.

Port Location, Extend, Cap and Retract, Head:

Enter location in degrees in reference to base or blind end lug.

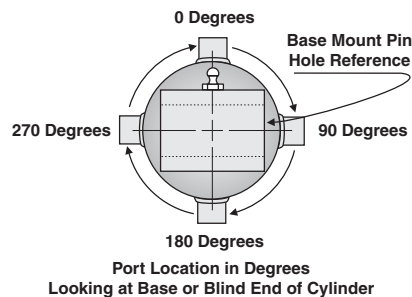

Please contact the factory for following options other than "N"

Rod and Base Mount Bushings

Special Seals

Special Rod Coatings (Nitrated, Stainless, Electroless Nickel-Plated)

Non Cataloged Mounts

Non Cataloged Porting

Air Bleeds

Flow Tubes

Lift Lugs

Pad Support Mounts

Position Sensing

Proximity Switch

Special Porting

Special Valving (Counterbalance, Holding, Lock)

Rod End Bellows

Cylinder Mounting Accessories

Rod Clevis

Material: CD 1/2, 3/4, 1 Forging, 1-3/8 & Up Ductile Iron Casting

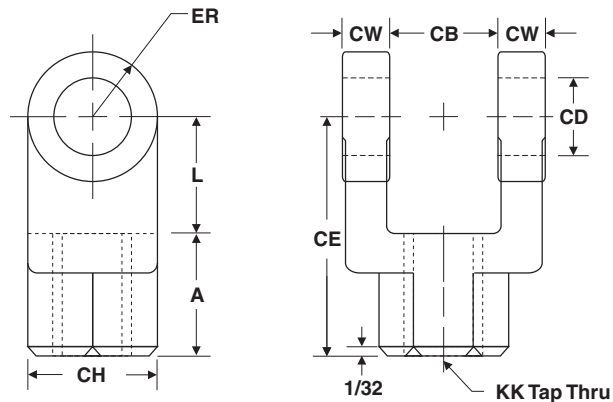

Part No.	CB	CD	CE	CH	CW	L	A	KK	ER
3753035079	0.765	1/2	1-1/2	1	1/2	3/4	3/4	7/16-20	1/2
3753035080	1.265	3/4	2-3/8	1-1/4	5/8	1-1/4	1-1/8	3/4-16	3/4
3753035081	1.515	1	3-1/8	1-1/2	3/4	1-1/2	1-5/8	1-14	1
3753035082	2.032	1-3/8	4-1/8	2	1	2-1/8	2	1-1/4-12	1-3/8
3753035084	2.531	1-3/4	4-1/2	2-3/8	1-1/4	2-1/4	2-1/4	1-1/2-12	1-3/4
3753035085	2.531	2	5-1/2	2-15/16	1-1/4	2-1/2	3	1-7/8-12	2
3753035086	3.032	2-1/2	6-1/2	3-1/2	1-1/2	3	3-1/2	2-1/4-12	2-1/2
3753035087	3.032	3	6-3/4	3-7/8	1-1/2	3-1/4	3-1/2	2-1/2-12	2-3/4
3753035088	4.032	3-1/2	8-1/2	5	2	4	4-1/2	3-1/4-12	3-1/2
3753035089	4.532	4	10	6-1/8	2-1/4	4-1/2	5-1/2	4-12	4

Spherical Rod Eye

Material: Forging, Weldment, or Ductile Iron

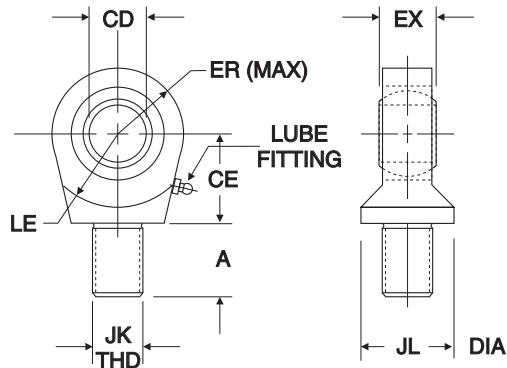

Part No.	CD	A	CE	EX	ER	LE	JK	JL Ref.	Load Cap.	Spacer Width
3753035192	0.500	11/16	7/8	7/16	7/8	3/4	7/16-20	7/8	2,600	.150
3753035193	0.750	1	1-1/4	21/32	1-1/4	1-1/16	3/4-16	1-5/16	9,400	.250
3753035194	1.000	1-1/2	1-7/8	7/8	1-3/8	1-7/16	1-14	1-1/2	16,800	.250
3753035195	1.375	2	2-1/8	1-3/16	1-13/16	1-7/8	1-1/4-12	2	28,600	.375
3753035196	1.750	2-1/8	2-1/2	1-17/32	2-3/16	2-1/8	1-1/2-12	2-1/4	43,000	.416
3753035197	2.000	2-7/8	2-3/4	1-3/4	2-5/8	2-1/2	1-7/8-12	2-3/4	70,000	.375

Cylinder Mounting Accessories

Rod Eyes

Material: CD 1/2 thru 1-3/8 C.F. Bar, 1-3/4 & Up Steel Plate

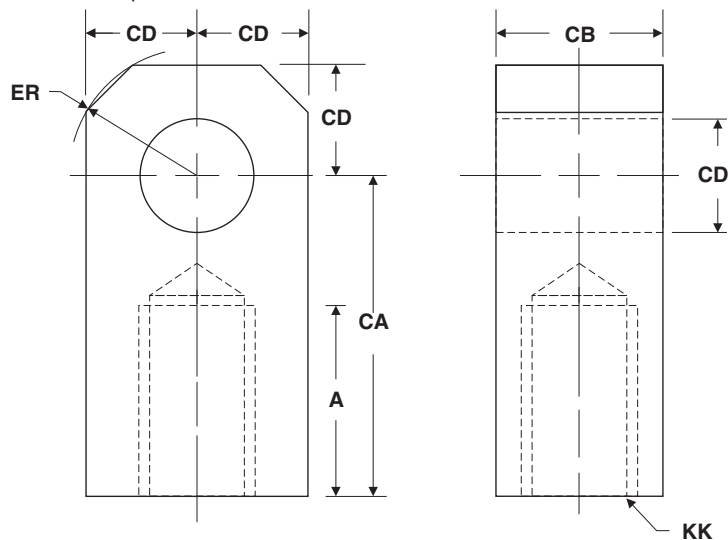

Part No.	A	CA	CB	CD	ER	KK
3753035096	3/4	1-1/2	3/4	1/2	5/8	7/16-20
3753035097	1-1/8	2-1/16	1-1/4	3/4	7/8	3/4-16
3753035098	1-5/8	2-13/16	1-1/2	1	1-3/16	1-14
3753035099	2	3-7/16	2	1-3/8	1-9/16	1-1/4-12
3753035100	2-1/4	4	2-1/2	1-3/4	2	1-1/2-12
3753035101	3	5	2-1/2	2	2-1/2	1-7/8-12
3753035102	3-1/2	5-13/16	2	2-1/2	2-13/16	2-1/4-12
3753035103	3-1/2	6-1/8	3	3	3-1/4	2-1/2-12
3753035104	4-1/2	7-5/8	4	3-1/2	3-7/8	3-1/4-12
3753035105	5-1/2	9-1/8	4-1/2	4	4-7/16	4-12

Pivot Pin

Material: 1144 Steel Nitrotec Treated Surface

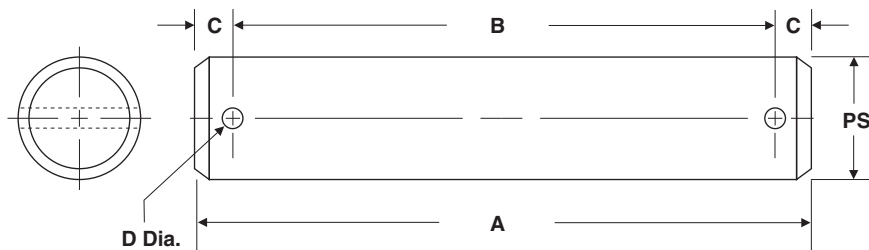

Part No.	Pin Size	A	B	C	D
3757244002	0.500	2.281	1.938	.172	.106
3757244003	0.750	3.094	2.719	.188	.140
3757244004	1.000	3.594	3.219	.188	.140
3757244005	1.375	4.656	4.250	.203	.173
3757244006	1.750	5.656	5.250	.203	.173
3757244007	2.000	5.719	5.281	.219	.201
3757244008	2.500	6.781	6.313	.234	.219
3757244009	3.000	6.844	6.344	.250	.250
3757244010	3.500	8.969	8.406	.282	.312
3757244011	4.000	9.969	9.406	.282	.321

Cylinder Mounting Accessories

Alignment Coupler

1/16 Radial Float 2° Spherical Motion

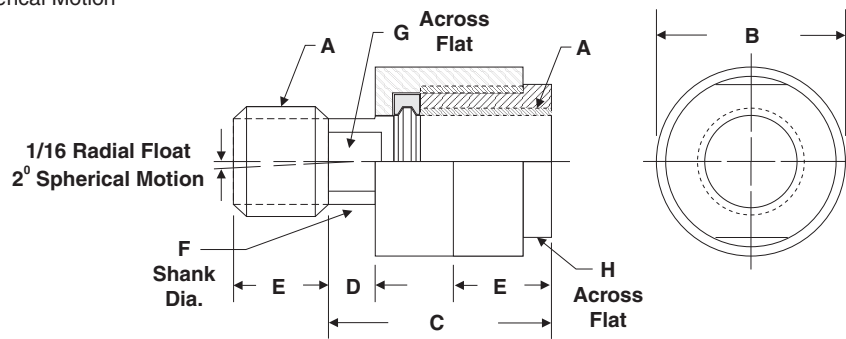

Part No.	A	B	C	D	E	F	G	H	Max. Pull at Yield
3753035078	1/4-28	7/8	1-1/4	1/4	5/8	5/16	3/16	3/4	6,000
3750484033	5/16-24	7/8	1-1/4	1/4	5/8	5/16	1/4	3/4	8,300
3750484034	3/8-24	7/8	1-1/4	1/4	5/8	5/16	5/16	3/4	8,300
3750484035	3/8-16	7/8	1-1/4	1/4	5/8	5/16	5/16	3/4	5,000
3750484036	7/16-20	1-1/4	2	1/2	3/4	5/8	1/2	1	10,000
3750484037	1/2-20	1-1/4	2	1/2	3/4	5/8	1/2	1	14,000
3750484038	1/2-13	1-1/4	2	1/2	3/4	5/8	1/2	1	14,000
3750484039	5/8-18	1-1/4	2	1/2	3/4	5/8	1/2	1	19,000
3750484040	3/4-16	1-3/4	2-5/16	1/2	1-1/8	31/32	13/16	1-1/2	34,000
3750484041	3/4-10	1-3/4	2-5/16	1/2	1-1/8	31/32	13/16	1-1/2	34,000
3750484042	7/8-14	1-3/4	2-5/16	1/2	1-1/8	31/32	13/16	1-1/2	39,000
3750484029	1-14	2-1/2	2-15/16	1/2	1-5/8	1-3/8	1-5/32	2-1/4	64,000
3750484030	1-1/4-12	2-1/2	2-15/16	1/2	1-5/8	1-3/8	1-5/32	2-1/4	78,000
3750484031	1-1/2-12	3-1/4	4-3/8	13/16	2-1/4	1-3/4	1-1/2	3	134,000
3753035077	1-3/4-12	3-1/4	4-3/8	13/16	2-1/4	1-3/4	1-1/2	3	134,000
3750484032	1-7/8-12	3-3/4	5-7/16	7/8	3	2	1-7/8	3-1/2	240,000
3750484044	2-12	3-3/4	5-7/16	7/8	3	2	1-7/8	3-1/2	240,000

Cylinder Mounting Accessories

Clevis Bracket

Material: Forging, Weldment, or Ductile Iron

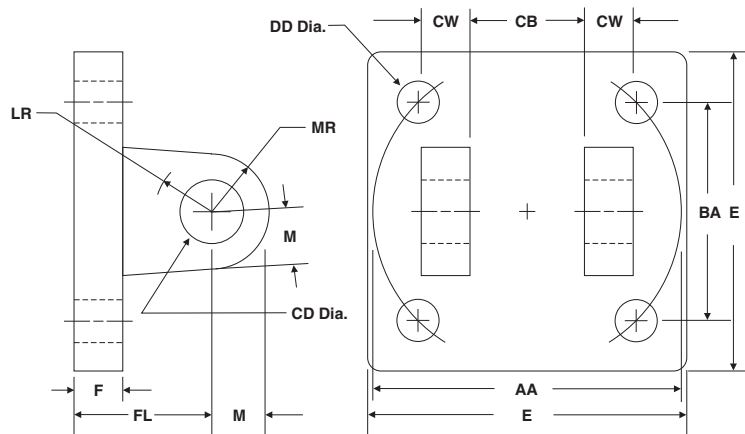

Part No.	AA	BA	CB	CD	CW	DD	E	F	FL	LR	M	MR
3753035090	2.3	1-5/8	0.765	1/2	1/2	3/8-24	2-1/2	3/8	1-1/8	1/2	1/2	9/16
3753035091	2.9	2-1/16	1.265	3/4	5/8	1/2-20	3	5/8	1-7/8	1	3/4	1-1//16
3753035092	3.6	2-9/16	1.265	3/4	5/8	1/2-20	3-1/2	5/8	1-7/8	1-1/16	3/4	1-1//16
3753035093	4.6	3-1/4	1.515	1	3/4	5/8-18	4-1/2	3/4	2-1/4	1-1/4	1	1-1/8
3753035094	5.4	3-13/16	2.032	1-3/8	1	5/8-18	5	7/8	3	1-7/8	1-3/8	1-3/4
3753035095	8.1	5-3/4	2.531	2	1-1/4	1-14	7-1/2	1	3-1/2	2-1/8	2	2-1/8

Eye Bracket

Material: Forging, Weldment, or Ductile Iron

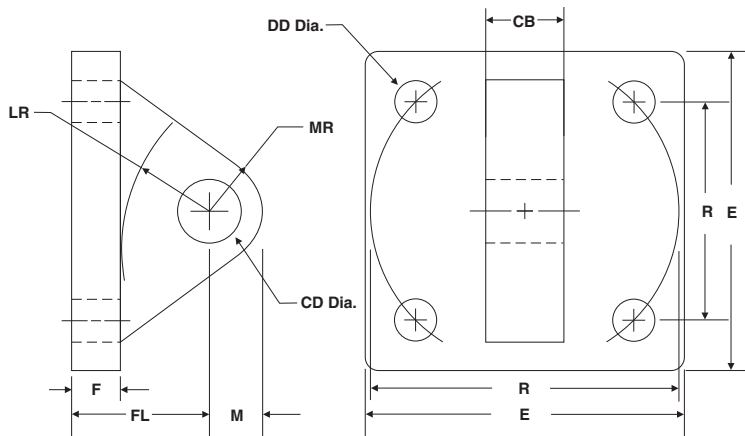

Part No.	CB	CD	DD	E	F	FL	LR	M	MR	R
3753035106	3/4	1/2	13/32	2-1/2	3/8	1-1/8	3/4	1/2	9/16	1.63
3753035107	1-1/4	3/4	17/32	3-1/2	5/8	1-7/8	1-1/4	3/4	7/8	2.56
3753035108	1-1/2	1	21/32	4-1/2	3/4	2-1/4	1-1/2	1	1-1/4	3.25
3753035109	2	1-3/8	21/32	5	7/8	3	2-1/8	1-3/8	1-5/8	3.81
3753035110	2-1/2	1-3/4	29/32	6-1/2	7/8	3-1/8	2-1/4	1-3/4	2-1/8	4.95
3753035111	2-1/2	2	1-1/16	7-1/2	1	3-1/2	2-1/2	2	2-7/16	5.75
3753035112	3	2-1/2	1-3/16	8-1/2	1	4	3	2-1/2	3	6.59
3753035113	3	3	1-5/16	9-1/2	1	4-1/4	3-1/4	3	3-1/4	7.50

Piston Rod Cylinder Application Data Form

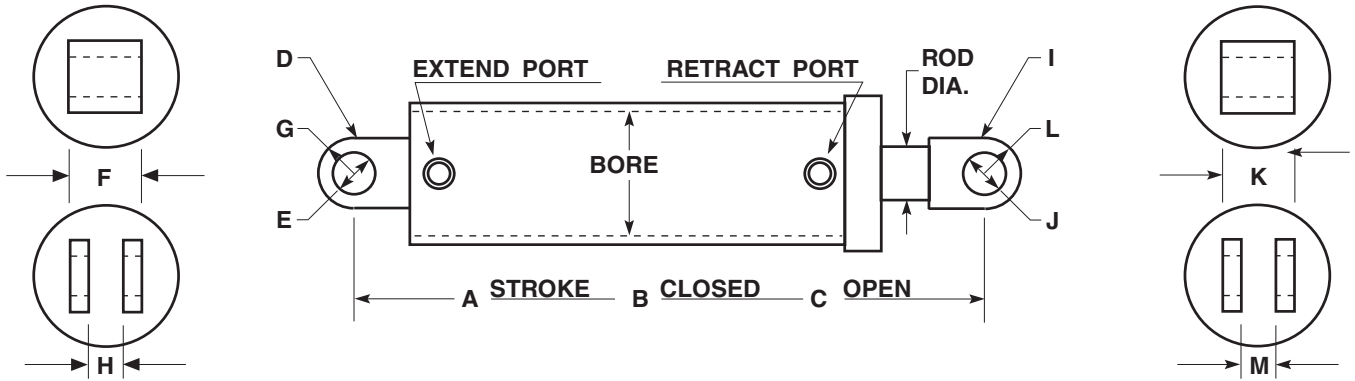

Cylinder application _____

Single- or Double-acting _____ System operating pressure Normal ____ Max. ____

Bore _____ Is there a relief valve in system ____ Setting ____

Rod diameter _____ System flow in G.P.M Min. ____ Max. ____

Head & gland design _____ System operating temp. Normal ____ Max. ____

Piston design _____ Fluid type _____

Mounting conditions ____Vert. ____Horz. ____Incline angle Load holding requirements _____

Any side or eccentric loading possible _____ Environmental condition _____

A : Total stroke _____

B : Closed length _____

C : Open length _____

D : Base mount type or code _____ I : Plunger mount type or code _____

E : Base pin diameter _____ J : Plunger pin diameter _____

F : Base mount width _____ K : Plunger mount width _____

G : Base mount radius _____ L : Plunger mount radius _____

H : Base Clevis Gap (if applicable) _____ M : Plunger clevis gap (if applicable) _____

Special mounting (if applicable) _____

Extend port size and type _____ Extend port location _____

Retract port size and type _____ Retract port location _____

Special features or comments _____

Requested by: Firm _____ Current Quan. _____

Address _____ Future Quan. _____

City _____ State _____ Zip _____

Phone _____ Fax _____

Contact _____

Phone: (800) 848-5575 * 330-480-8431 * Fax (800) 694-3392 * 330-480-8432

Service Parts and Rebuild Kits for "M" Series

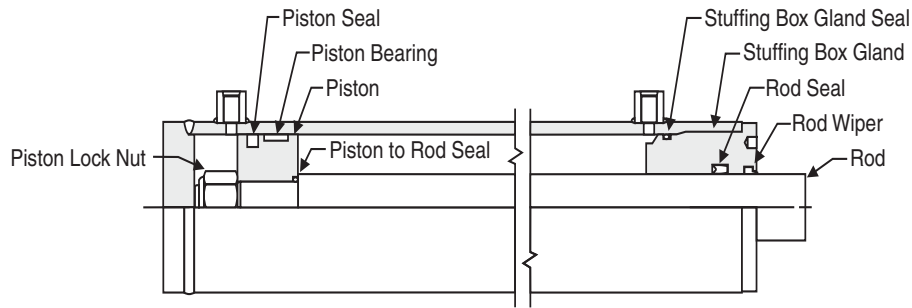

WMD Series	Bore Size	Rod Dia.	Seal Kit Part Number	Stuffing Box Part Number	Piston Part Number	Piston Nut Part Number
M-P-20-10-N	2.00	1.000	3751805283	BM02010020	PM02001012	3911457008
M-P-20-11-N	"	1.125	3751805284	BM02011220	"	"
M-P-20-12-N	"	1.250	3751805285	BM02012520	"	"
M-P-25-10-N	2.50	1.000	3751805288	BM02510022	PM25012516	3911457008
M-P-25-11-N	"	1.125	3751805289	BM02511222	"	"
M-P-25-12-N	"	1.250	3751805290	BM02512522	"	"
M-P-25-13-N	"	1.375	3751805291	BM02513822	"	"
M-P-25-15-N	"	1.500	3751805292	BM02515022	"	"
M-P-25-17-N	"	1.750	3751805293	BM02517522	"	"
M-P-30-10-N	3.00	1.000	3751805295	BM03010022	PM30015019S	3911457008
M-P-30-11-N	"	1.125	3751805296	BM03011222	"	"
M-P-30-12-N	"	1.250	3751805297	BM03012522	"	"
M-P-30-13-N	"	1.375	3751805298	BM03013822	"	"
M-P-30-15-N	"	1.500	3751805299	BM03015022	"	"
M-P-30-17-N	"	1.750	3751805300	BM03017522	"	"
M-P-30-20-N	"	2.000	3751805301	BM03020022	"	"
M-P-32-12-N	3.25	1.250	3751805302	BM03212522	PM32015024	3911457010
M-P-32-13-N	"	1.375	3751805303	BM03213822	"	"
M-P-32-15-N	"	1.500	3751805304	BM03215022	"	"
M-P-32-17-N	"	1.750	3751805305	BM03217522	"	"
M-P-32-20-N	"	2.000	3751805306	BM03220022	"	"
M-P-35-12-N	3.50	1.250	3751805307	BM03512525	PM35015024S	3911457010
M-P-35-13-N	"	1.375	3751805308	BM03513825	"	"
M-P-35-15-N	"	1.500	3751805309	BM03515025	"	"
M-P-35-17-N	"	1.750	3751805310	BM03517525	"	"
M-P-35-20-N	"	2.000	3751805311	BM03520025	"	"
M-P-35-25-N	"	2.500	3751805313	BM03525025	"	"
M-P-40-13-N	4.00	1.375	3751805314	BM04013825	PM40015024	3911457010
M-P-40-15-N	"	1.500	3751805315	BM04015025	"	"
M-P-40-17-N	"	1.750	3751805316	BM04017525	"	"
M-P-40-20-N	"	2.000	3751805317	BM04020025	"	"
M-P-40-25-N	"	2.500	3751805319	BM04025025	"	"
M-P-40-30-N	"	3.000	3751805320	BM04030025	"	"
M-P-45-17-N	4.50	1.750	3751805321	BM04517525	PM45015025S	3911457011
M-P-45-20-N	"	2.000	3751805322	BM04520025	"	"
M-P-45-25-N	"	2.500	3751805324	BM04525025	"	"
M-P-45-30-N	"	3.000	3751805325	BM04530025	"	"
M-P-45-35-N	"	3.500	3751805326	BM04535025	"	"
M-P-50-20-N	5.00	2.000	3751805327	BM05020025	PM50015030	3751457002
M-P-50-25-N	"	2.500	3751805329	BM05025025	"	"
M-P-50-30-N	"	3.000	3751805330	BM05030025	"	"
M-P-50-35-N	"	3.500	3751805331	BM05035025	"	"
M-P-50-40-N	"	4.000	3751805332	BM05040025	"	"

Service Parts and Rebuild Kits for "H" Series

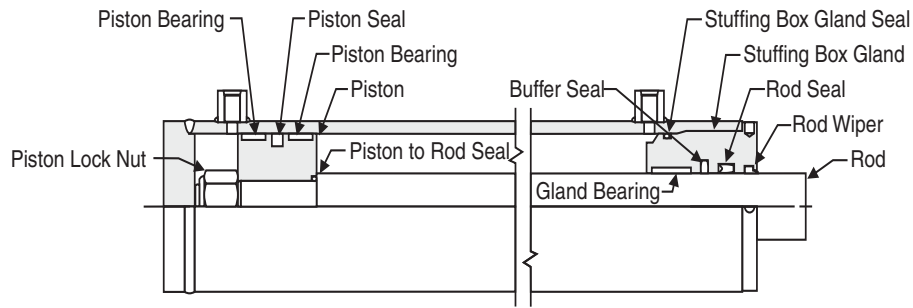

WHD Series	Bore Size	Rod Dia.	Seal Kit Part Number	Stuffing Box Part Number	Piston Part Number	Piston Nut Part Number
H-P-30-13-N	3.00	1.375	3751805366	BH03013830	PH30020021	3751457001
H-P-30-15-N	"	1.500	3751805367	BH03015030	"	"
H-P-30-17-N	"	1.750	3751805368	BH03017530	"	"
H-P-30-20-N	"	2.000	3751805369	BH03020030	"	"
H-P-32-12-N	3.25	1.250	3751805370		PH32020023	3911451010
H-P-32-13-N	"	1.375	3751805371		"	"
H-P-32-15-N	"	1.500	3751805372		"	"
H-P-32-17-N	"	1.750	3751805373		"	"
H-P-32-20-N	"	2.000	3751805374		"	"
H-P-35-12-N	3.50	1.250	3751805375	BH03512530	PH35020025	3911457011
H-P-35-13-N	"	1.375	3751805376	BH03513830	"	"
H-P-35-15-N	"	1.500	3751805377	BH03515030	"	"
H-P-35-17-N	"	1.750	3751805378	BH03517530	"	"
H-P-35-20-N	"	2.000	3751805379	BH03520030	"	"
H-P-35-25-N	"	2.500	3751805381	BH03525030	"	"
H-P-40-13-N	4.00	1.375	3751805382	BH04013835	PH40020025	3911457011
H-P-40-15-N	"	1.500	3751805383	BH04015035	"	"
H-P-40-17-N	"	1.750	3751805384	BH04017535	"	"
H-P-40-20-N	"	2.000	3751805385	BH04020035	"	"
H-P-40-25-N	"	2.500	3751805387	BH04025035	"	"
H-P-40-30-N	"	3.000	3751805388	BH04030035	"	"
H-P-45-17-N	4.50	1.750	3751805389	BH04517535	PH45020030	3751457002
H-P-45-20-N	"	2.000	3751805390	BH04520035	"	"
H-P-45-25-N	"	2.500	3751805392	BH04525035	"	"
H-P-45-30-N	"	3.000	3751805393	BH04530035	"	"
H-P-45-35-N	"	3.500	3751805394	BH04535035	"	"
H-P-50-20-N	5.00	2.000	3751805395	BH05020037	PH50020035	3911457013
H-P-50-25-N	"	2.500	3751805397	BH05025037	"	"
H-P-50-30-N	"	3.000	3751805398	BH05030037	"	"
H-P-50-35-N	"	3.500	3751805399	BH05035037	"	"
H-P-50-40-N	"	4.000	3751805400	BH05040037	"	"
H-P-55-25-N	5.50	2.500	3751805401	BH05525037	PH55021240S	3911457013
H-P-55-30-N	"	3.000	3751805402	BH05530037	"	"
H-P-55-35-N	"	3.500	3751805403	BH05535037	"	"
H-P-55-40-N	"	4.000	3751805404	BH05540037	"	"
H-P-55-45-N	"	4.500	3751805405	BH05545037	"	"
H-P-60-25-N	6.00	2.500	3751805406	BH06025037	PH60021245S	3751457046
H-P-60-30-N	"	3.000	3751805407	BH06030037	"	"
H-P-60-35-N	"	3.500	3751805408	BH06035037	"	"
H-P-60-40-N	"	4.000	3751805409	BH06040037	"	"
H-P-60-45-N	"	4.500	3751805410	BH06045037	"	"
H-P-70-25-N	7.00	2.500	3751805411	BH07025042	PH70021245	3751457050
H-P-70-30-N	"	3.000	3751805412	BH07030042	"	"
H-P-70-35-N	"	3.500	3751805413	BH07035042	"	"
H-P-70-40-N	"	4.000	3751805414	BH07040042	"	"
H-P-70-45-N	"	4.500	3751805415	BH07045042	"	"
H-P-80-35-N	8.00	3.500	3751805416	BH08035042	PH80031249	3751457050
H-P-80-40-N	"	4.000	3751805417	BH08040042	"	"
H-P-80-45-N	"	4.500	3751805418	BH08045042	"	"

WMD and WHD Series Disassembly Instructions

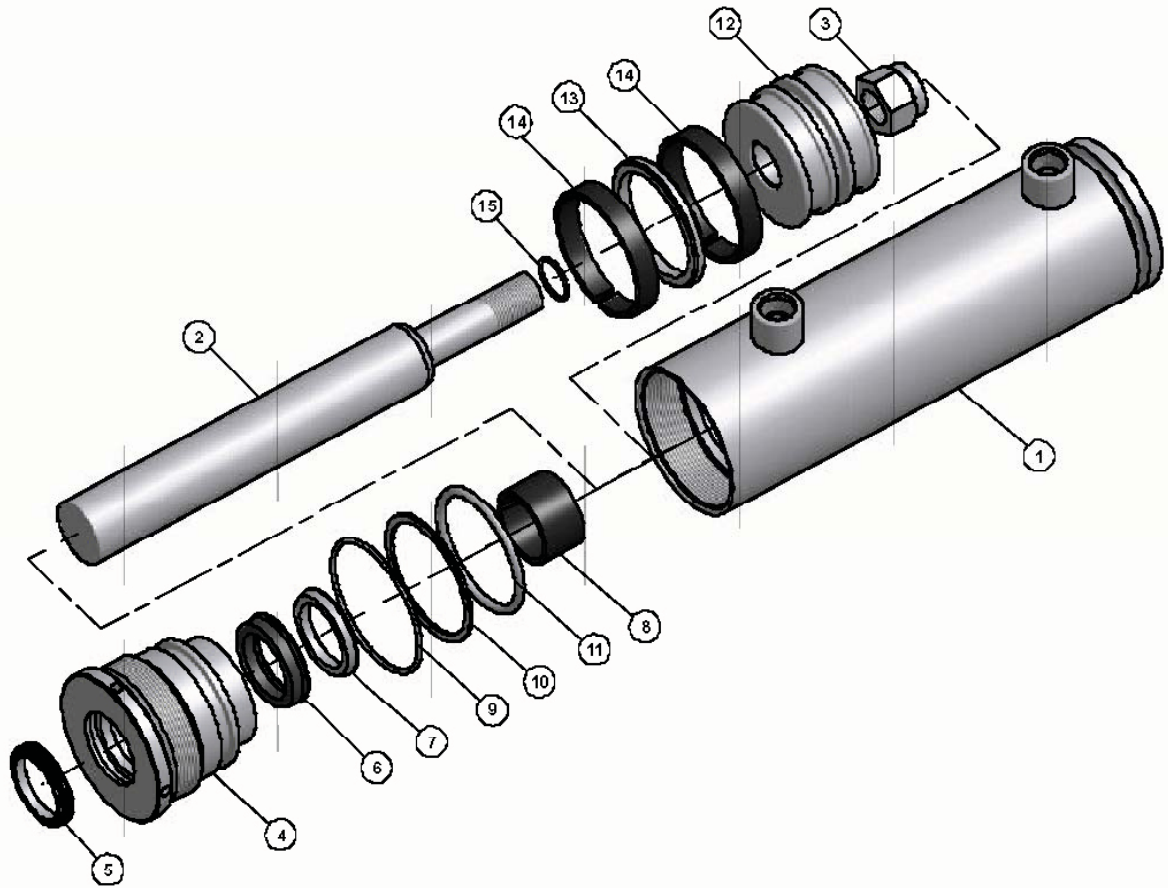
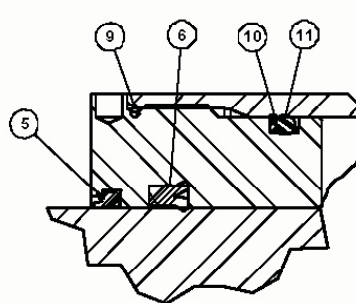

Figure 1. Standard cylinder assembly of seal(s), wiper, backup and o-ring.

Key to Part Numbers:

1. Cylinder Main (case)
2. Cylinder Rod
3. Elastic Stop Nut
4. Stuffing Box (head)
5. Wiper
6. Rod Seal
7. Buffer Seal
8. Wear Ring
9. O-ring
10. Back-up Ring
11. O-ring
12. Piston
13. Piston Seal
14. Wear Ring(s)
15. O-ring
16. Self-tapping screw



MEDIUM DUTY STUFFING BOX

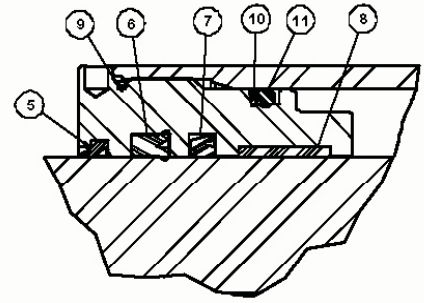

HEAVY DUTY STUFFING BOX

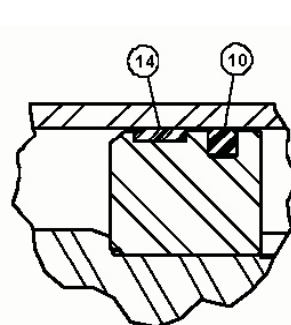

MEDIUM DUTY PISTON

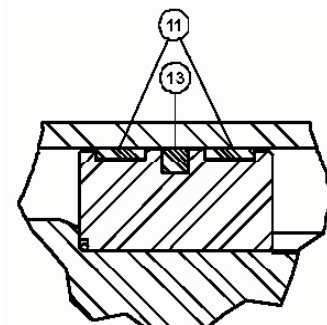

HEAVY DUTY PISTON

WMD and WHD Series Disassembly instructions

Before getting started:

- Ensure the work environment is clean and safe.
- Remove port plugs (if any) and drain excess oil.

A) Cylinder disassembly

1. Remove self-tapping screw where head meets the case or set screw on side of case.
2. Open the cylinder by using a spanner wrench to turn the head counter clock-wise. The head may be tight due to the manufacture's torque requirement.
3. After head is turned $\frac{3}{4}$ of the way out, support the rod the rest of the way to prevent rod hitting the thread.
4. Be sure not to scratch the rod when removing from case and set it on a clean surface. Note that the surface finish of the rod is crucial to the cylinder's overall quality.

B) Rod disassembly

1. Uninstall elastic stop nut (#3) by using a torque socket wrench turning counter clock-wise. The nut may be difficult due to the manufacture's required torque specification (250 lb/ft ~ 500 lb/ft). Since the surface finish of the rod is crucial to the cylinder's overall quality, use a vise to hold the mount only and support the rest of the rod with a clothed support.
2. Uninstall piston by pulling piston out aligning with the rod so that the piston will not damage the threads.
3. Uninstall head (#4) by sliding over the threaded rod end. Maintain alignment between rod and head to prevent damage to the thread.

C) Piston disassembly. Please refer to fig.1 for seals, back-up, and o-ring number. These processes may require a seal pick and/or 90 degree seal pick, be cautious not to score the piston wall.

1. Uninstall wear ring(s) (#14) by inserting the tip of the screw driver underneath the wear ring and pry it out. Use the split embedded on one of wear ring to reduce the OD by overlapping the ends. Use caution when uninstalling, although wear ring is made to be flexible, it is also brittle.
2. Repeat same step for second wear ring
3. Uninstall piston seal and energizer ring (#13), using a seal pick to pry it out, and in a circular motion to expand the circumference of the seal. The increased circumference will enable the seal to slide out more efficiently.
4. Uninstall o-ring (#15) is located inside the piston furthest away from the elastic stop nut end. Uninstall it by prying it out with a seal pick.

D) Head disassembly Please refer to fig.1 for respective seals, back-up, and o-ring number. These processes require a seal pick but caution should be used not to score the ID of the head.

1. Uninstall back-up & o-ring (outside head) by inserting the tip of the seal pick underneath the seal, prying it out, and in a circular motion to expand the circumference of the seal. The increased circumference will enable the seal to slide out more efficiently.
 - a. Uninstall o-ring (#11) first before back-up (#10).
 - b. Uninstall back-up (#10)
 - c. Uninstall o-ring (#9)
2. Uninstall head seal(s) (inside head) using the same method as (outside head).
 - a. Uninstall wear ring #8. The split in the wear ring will allow it to come compress and taken out more effectively. Use caution when uninstalling, although wear ring is made to be flexible, it is also brittle.
 - b. Uninstall seal #7
 - c. Uninstall seal #6
 - d. Uninstall seal #5

TOOL LIST:

- Spanner wrench
- Seal pick
- Flat head screw driver
- Seal lubricant (Petroleum Jelly)
- Anti-seize
- Loctite 242

WMD and WHD Series Assembly Instructions

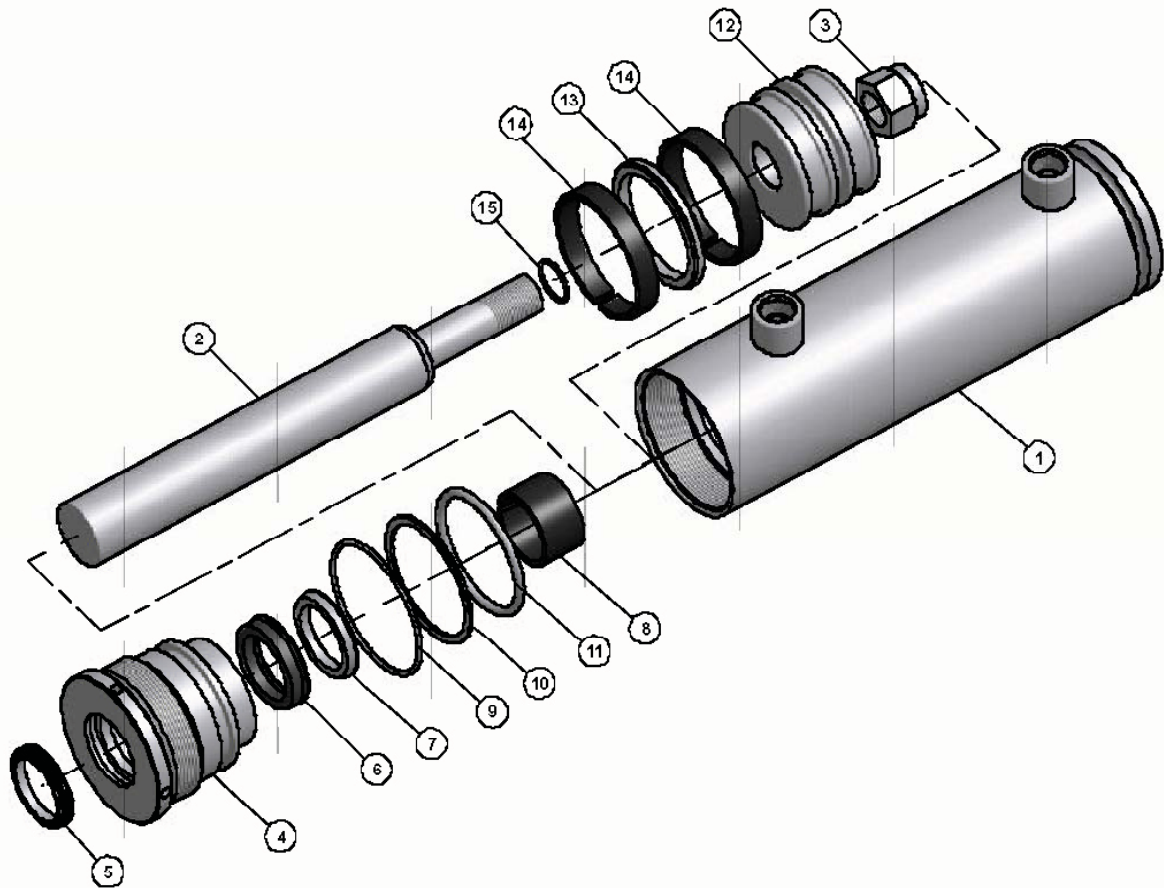
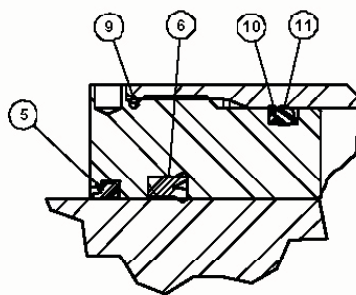

Figure 1. Standard cylinder assembly of seal(s), wiper, backup and o-ring.

Key to Part Numbers:

1. Cylinder Main (case)
2. Cylinder Rod
3. Elastic Stop Nut
4. Stuffing Box (head)
5. Wiper
6. Rod Seal
7. Buffer Seal
8. Wear Ring
9. O-ring
10. Back-up Ring
11. O-ring
12. Piston
13. Piston Seal
14. Wear Ring(s)
15. O-ring
16. Self-tapping screw



MEDIUM DUTY STUFFING BOX

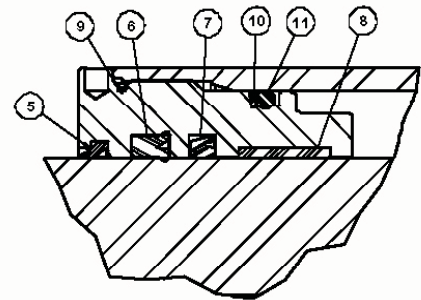

HEAVY DUTY STUFFING BOX

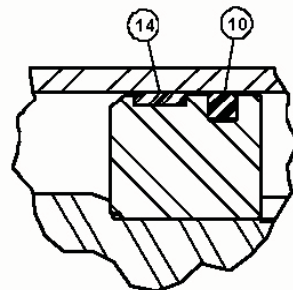

MEDIUM DUTY PISTON

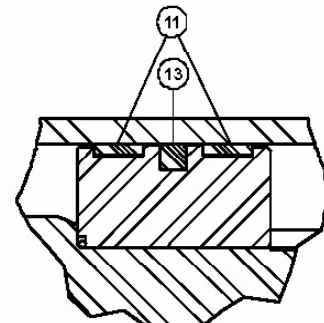

HEAVY DUTY PISTON

WMD and WHD Series Assembly instructions

Before getting started:

- Ensure the work environment is clean and safe.

A) Clean

Clean head, piston, rod and case with water and small amount of soap. The parts must be dried quickly after washing to prevent possible corrosion.

B) Head Assembly Please refer to fig. 1 for respective seals, back-up, and o-ring installation order.

1) Install head seal(s) (inside head).

- a) Install wiper #5. This seal should be fairly easy to install. Note that the wider end should align towards the bottom of the head.
- b) Install seal #6. See fig. 2 for seal #6 instructions.

1. Insert C to the inside wall of the head to use as leverage. Note, the grooved side of the seal should be oriented as the bottom and the flat as top. Figure 1, seal #6 illustrates the proper orientation. Note that the smaller the seal, the more difficult to bend.

2. Now that C is inside the wall of the head, push in at A. Bending motion might require both hands if necessary. Bend B and D inward towards the thumb arrow. The seal might have to be slightly bending up towards the installer to maintain a smaller seal radius to fit inside wall of the head. Slowly slide B and D into the seal groove and release the seal to its original shape. Use a seal pick for leverage if necessary. Care should be taken to not damage the ID or OD sealing lips.

Figure 2. Installation instruction for rod U-seal #6

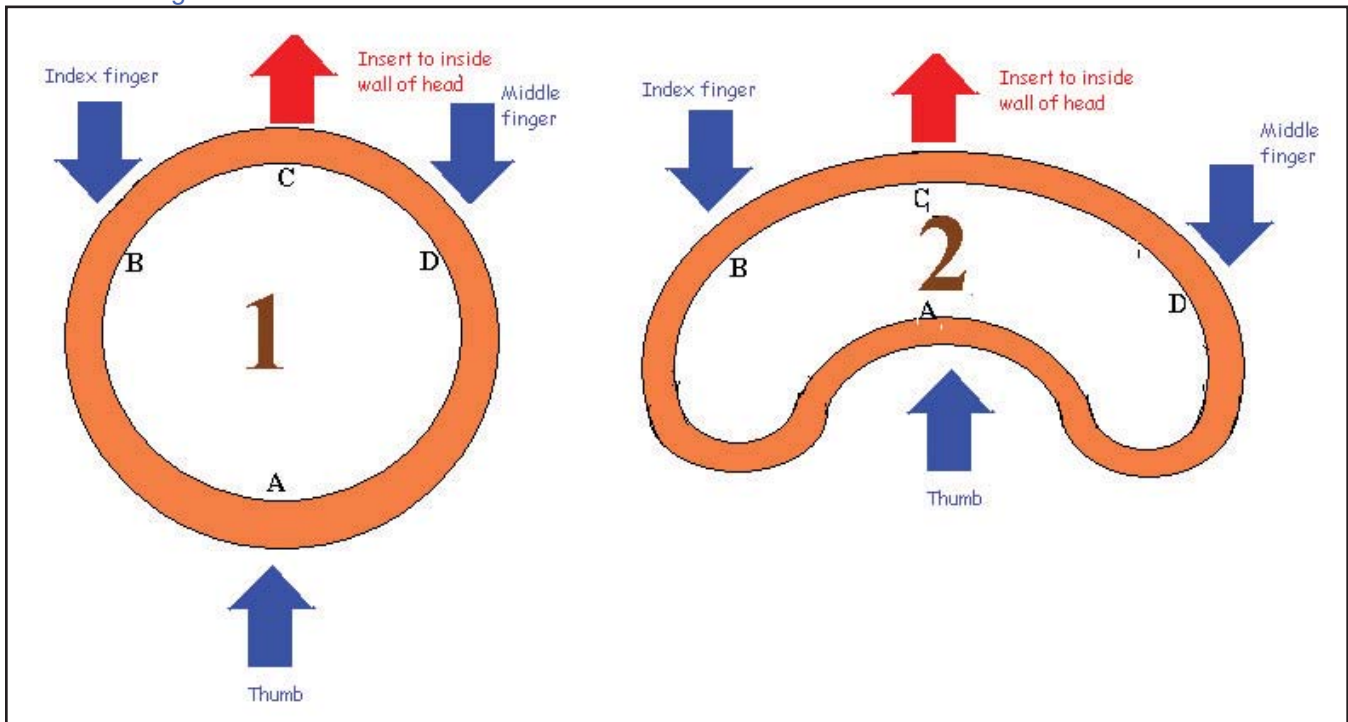

- c) Install buffer seal#7. This seal is more elastic than rod U-seal#6, therefore the circumference is easier to reduce to install inside the head. After installing the seal, use finger to ensure the seal is properly place.
- d) Install wear ring #8 (inside head). Use caution when installing, although wear ring is made to be flexible, wear ring is also brittle.
 1. Compress the wear ring into a smaller circumference.
 2. Insert wear ring into inside wall of head.

WMD and WHD Series Assembly instructions

- 2) Install back-up & o-ring (outside head).
 - a) Install o-ring (#9). This o-ring is designed to simply roll in place.
 - b) Install back-up ring (#10). The back-up ring helps keep the o-ring (#11) in place. The flat side must be adjacent to the wall and the concaved side must face the o-ring (#11).
 - c) Install o-ring (#11) adjacent to back-up (#10). The o-ring should fit into concaved side of the back-up.

C) Piston Assembly Please refer to fig. 1 for respective seals, back-up, and o-ring installation order.

- 1) Install o-ring (#15).
 - a) O-ring (#15) is to be placed inside of the piston furthest away from the elastic stop nut.
 - b) Press the o-ring against the inside wall to ensure the seal will not fall out
- 2) Install piston seals (#13). This is a two piece seal with a Buna energizer and Bronze filled PTFE outer seal.
 - a) Seal may not provide sufficient elasticity to slide in place. Aid of a tool such as pick may necessary for installation but please avoid sharp object.
 - b) After installing, ensure seal is properly place inside of seal groove.
 - c) Energizer (bronze) will need to be stretched to fit over piston and into proper groove.
 - d) Place tough Styrofoam sheet around the energizer to prevent any possible damages when using a chain wrench to compress the energizer.
- 3) Install wear ring(s) (#14). Use caution when installing, although wear ring is made to be flexible, wear ring is also brittle.
 - a) Open the circumference of the wear ring providing just enough clearance to slide over the piston. Position in the wear ring groove.
 - b) Repeat same step for second wear ring

D) Rod Assembly Instruction for rod only. Please refer to fig. 1 for respective head and piston orientation on rod.

- 1) Install stuffing box (head) (add lubricant before installation)
 - a) Add lubrication (strongly recommend petroleum jelly) to the ID (inside) wiper.
 - b) Slide the head onto the threaded end of the rod since other end will have a mount which prevents the head from sliding in.
 - c) Use caution not to damage the threads on piston stud.
 - d) Gently rock head up-and-down if necessary when sliding head towards mount. Note that the sliding motion should require a firm push; otherwise the seals are installed improperly.
- 2) Install piston (add lubrication before installation)
 - a) Add lubrication (strongly recommend petroleum jelly) to the inside wall.
 - b) Place the piston next to the threaded end of the rod. Check to make sure the piston is aligned with the rod. Slowly push the piston so the threads and piston is align, preventing damage to the threads.
 - c) Slowly slide the piston up until it meets the major rod diameter. O-ring (#15) should be flush against the leading edge.
- 3) Install elastic stop nut
 - a) After the piston is installed, an elastic stop nut is placed behind piston to prevent it from coming out.
 - b) Turn the nut clock-wise until tight.
 - c) Torque the nut to the require specification (250 lb/ft ~ 500 lb/ft). Refer to table 1. for torque specification.

WMD and WHD Series Assembly instructions

Table 1. Piston Nut torque specification

Stud Diameter (inches)	Torque (ft-lbs)
0.75	242
0.875	275
1.00	325
1.12	375
1.25	400
1.50	425
1.75	450
2.00	500

- 4) Lubricate (strongly recommend petroleum jelly) seals and o-rings to aid assembly.

E) Cylinder Assembly

- 1) Install rod assembly
 - a. Lubricate (strongly recommend petroleum jelly) counter bore, incase below thread. Lightly grease piston and head seals, O-ring, back-up, and wear rings. Apply never seize on head.
 - b. Gently insert rod in, piston end first. Push rod all the way in until the head meets the open end of the case. Leave enough distance between the head and mount to provide room for turning the head.
 - c. Slowly turn the head clock-wise manually by hand to ensure the head and case thread is aligned. If the head is difficult to turn after the first few turns, stop and retrieve the head back out. Check the threads for possible foreign objects, wipe the head, realign and screw it back in.
 - d. After head is turned $\frac{3}{4}$ of the way into the case by hand, it may be difficult to proceed. For this purpose, a spanner wrench is required.
 - e. Torque head until firmly seated in case (torque requirement).
- 2) Drill a small diameter hole (size 28) $\frac{9}{32}$ " inches deep where head gland meets the case and install self tapping screw. IF there is a set screw hole, omit self tapping screw and add thread locker (Loctite #242) to set screw and install. Please refer to figure for illustration.

Figure 3. Installation of self tapping screw.

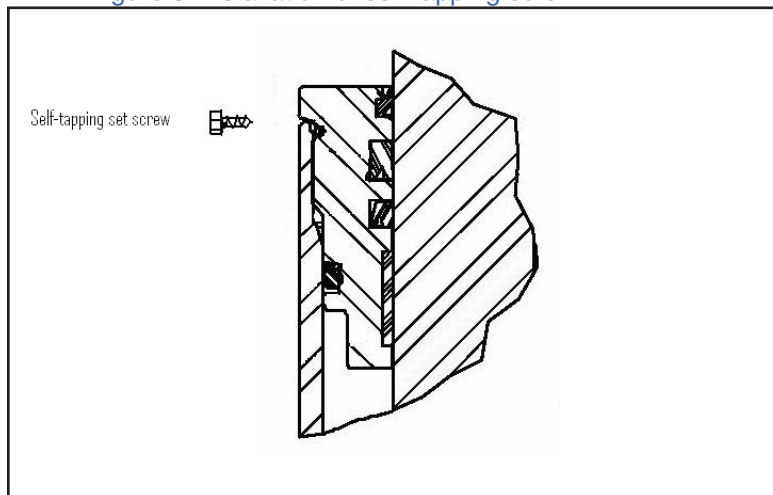

TOOL LIST:

- Spanner wrench
- Seal pick
- Flat head screw driver
- Seal lubricant (Petroleum Jelly)
- Anti-seize
- Loctite 242

Designing With Cylinders

The basis for all hydraulic systems is expressed by Pascal's law which states that the pressure exerted anywhere upon an enclosed liquid is transmitted undiminished, in all directions, to the interior of the container. This principle allows large forces to be generated with relatively little effort. As illustrated, a 5 pound force exerted against a 1 inch square area creates an internal pressure of 5 psi. This pressure, acting against the 10 square inch area develops 50 pounds of force.

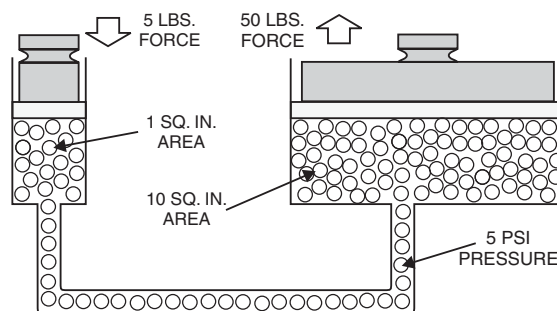

In a basic hydraulic circuit, the force exerted by a cylinder is dependent upon the cylinder bore size and the pump pressure. (There is no force generated unless there is resistance to the movement of the piston). With 1000 psi pump pressure exerted against a 12 square inch piston area (approximately 4" dia.), a force of 12,000 pounds is developed by the cylinder. The speed at which the piston will move is dependent upon the flow rate (gpm) from the pump and the cylinder area. Hence, if pump delivery is 1 gallon per minute (231 cu. in./min.) the cylinder piston will move at a rate of 19.25 in./min. ($231 \text{ cu. in.} \div 12 \text{ sq. in./min.}$).

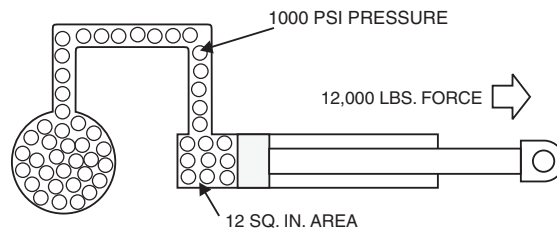

The simplest hydraulic circuit consists of a reservoir, pump, relief valve, 3-way directional control valve, single acting cylinder, connectors and lines. This system is used where the cylinder piston is returned by mechanical force. With the control valve in neutral, pump flow passes through the valve and back to the reservoir. With the valve shifted, oil is directed to the piston side of the cylinder, causing the piston to move, extending the rod. If the valve is returned to neutral, the oil is trapped in the cylinder, holding it in a fixed position, while pump flow is returned to the reservoir. Shifting the valve in the opposite direction permits the oil to pass through the valve back to the reservoir. The relief valve limits the system pressure to a pre-set amount. Relief valves are commonly incorporated into the directional control valve.

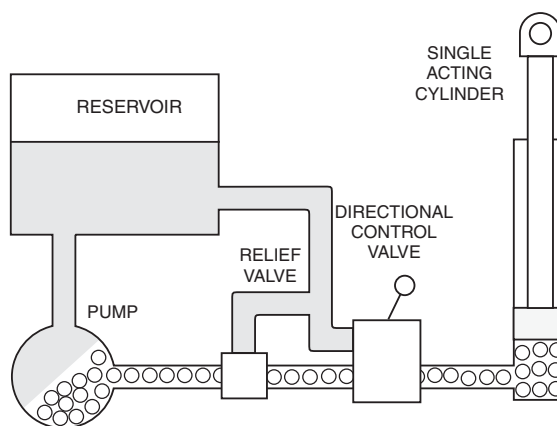

A hydraulic system using a double acting cylinder and a 4-way valve differs from a single acting cylinder system in that the cylinder can exert force in both directions. With the control valve in neutral, flow is returned to the reservoir. When shifted in one direction, oil is directed to the piston side of the cylinder, causing the cylinder to extend. Oil from the rod side passes through the valve back to the reservoir. If the valve is shifted to neutral, oil in the cylinder is trapped, holding it in a fixed position. When the valve is shifted in the opposite position, oil is directed to the rod side of the cylinder, causing the cylinder to retract. Oil from the piston side passes through the valve back to the reservoir. Cylinder extend force is the result of pressure (psi) times the piston area (minus any force resulting from the pressure acting against the rod side of the piston). Retract force is a result of the pressure (psi) times the area difference between the rod and the piston (minus any force resulting from pressure acting against the piston side of the cylinder).

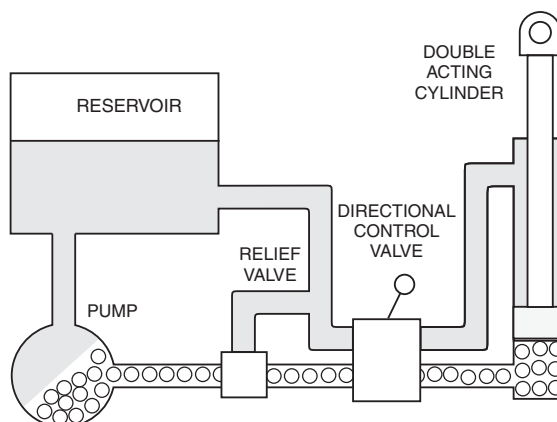

All of the systems described above are open center systems due to the oil flowing through the control valve back to the tank. Most systems are this type. Closed center systems use control valves with the inlet port blocked and variable displacement pumps. With the control valve in neutral, the pump is "de-stroked" to zero flow.

Designing With Cylinders

The function of a cylinder in a fluid power system is to convert energy in the fluid stream into an equivalent amount of mechanical energy. Its power is delivered in a straight-line, push-pull motion.

Graphic Symbols: Following diagram illustrates standard ANSI (American National Standards Institute) graphic symbols for use in circuit diagrams. Six of the more often used are shown:

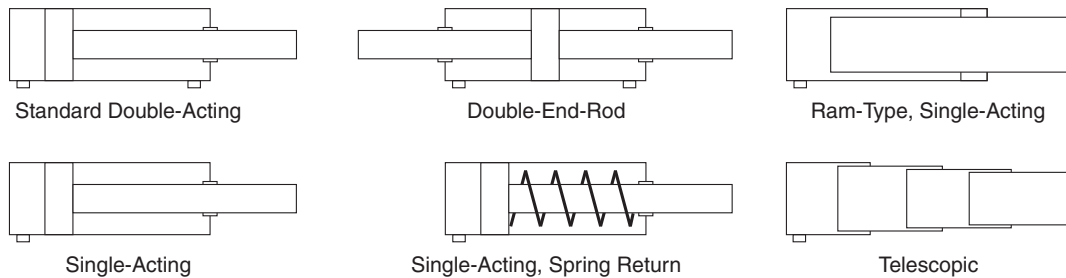

Standard ANSI (American National Standards Institute) Graphic Symbols for Use in Circuit Diagrams.

The standard double-acting cylinder with piston rod out one end, is used in the majority of applications. It develops force in both directions of piston travel. The double-end-rod type is a variation of the standard cylinder but having a piston rod extending out both end caps. It is occasionally used where it is necessary to have equal area on both sides of the piston, such as a steering application, or where one of rod extensions is to be used for mounting a cam for actuation of a limit switch, or for mounting a stroke limiting stop. The single-acting cylinder develops force in one direction, and is retracted by the reactive force from the load or an internal or external spring. The single-acting ram is a construction often used on fork lift mast raise, or a refuse body tailgate raise, or a high tonnage press cylinders. The telescoping cylinder is built in both single-acting and double-acting types. Its purpose is to provide a long stroke with a relatively short collapsed length. The single-acting telescopic is a construction often used to raise dump trucks and dump trailers. The double-acting telescopic is a construction often used in garbage bodies to pack and eject the load.

Force Produced by a Cylinder:

A standard double-acting cylinder has three significant internal areas. The full piston area when exposed to fluid pressure, produces force to extend the piston rod. The amount of this force, in pounds, is calculated by multiplying piston square inch area times gauge pressure, in PSI.

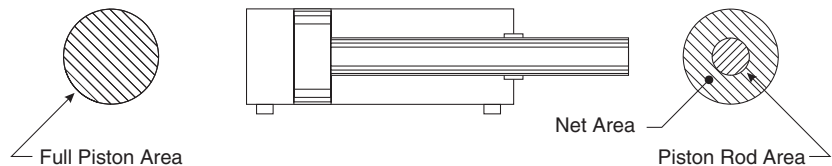

Significant Areas in a Double-Acting Cylinder, Single-End-Rod Type.

The "net" area on the front side of the piston is less than full piston area because part of the piston surface is covered by the rod. Net area is calculated by subtracting rod area from full piston area. Because net area is always less than piston area, cylinder force for rod retraction is always less than can be developed for extension when working at the same pressure.

Cylinder Force Against a Load: The force which a cylinder can exert against a load is determined by making two calculations. First, extension force is calculated according to piston area and PSI pressure against it. Then, the opposing force on the opposite side of the piston is calculated the same way. Net force against a load is the difference between the two.

Caution! It is incorrect, on a single-end-rod cylinder to calculate cylinder net force as piston area times ΔP (pressure drop, psid) across the piston. This is true only for double-end-rod cylinders which have equal areas on both sides of the piston.

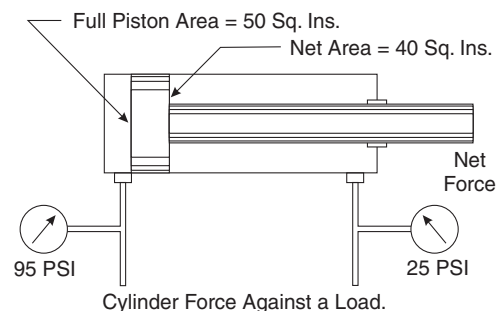

Example: The extension force is 95 PSI x 50 sq. in. = 4750 lbs. The opposing force on the rod side is 25 PSI x 40 sq. in. = 1000 lbs. Therefore, the net force which the cylinder can exert against a load in its extension direction is 4750 - 1000 = 3750 lbs. In making cylinder force calculation we sometimes assume that the opposite side of the piston is at atmospheric pressure, and that the counter-force is zero. On some kinds of loads this can lead to serious error.

Note: Most designers try to eliminate back pressure to get full extend force, but there will always be back pressure.

Designing With Cylinders

Standard catalog cylinder models are not designed to take any appreciable side load on the piston rod. They must be mounted so the rod is not placed in a bind at any part of the stroke. If the direction of the load changes during the stroke, hinge mounting must be used on both the rod end and rear end. Use guides on the mechanism, if necessary, to assure that no side load is transmitted to the cylinder rod or piston.

Rod Buckling

Column failure or buckling of the rod may occur if the cylinder stroke is too long relative to the rod diameter. The exact ratio of rod length to rod diameter at which column failure will occur cannot be accurately calculated, but the "Column Strength" table in this manual shows suggested safe ratios for normal applications.

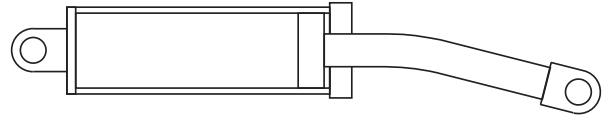

Tension and Compression Failures

All standard cylinders have been designed with sufficiently large piston rods so failure will never occur either in tension or compression, provided the cylinder is operated within the manufacturers pressure rating.

Rod Bearing Failure

Rod bearing failures usually occur when the cylinder is at maximum extension. Failures occur more often on hinge or trunnion mount cylinders, in which the rear support point is located considerably behind the rod bearing. If space permits, it is wise to order cylinders with longer stroke than actually required, and not permit the piston to approach to the front end while under full load.

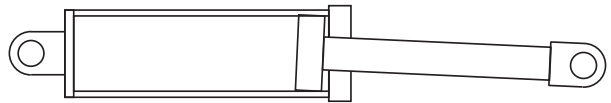

Stop Collar

On those application where it is necessary to let the piston "bottom out" on the front end, the cylinder may be ordered with a stop collar. The stop collar should be especially considered on long strokes if the distance between support exceeds 10 times the rod diameter, if the maximum thrust is required at full extension, and if the cylinder has a rear flange, clevis, tang, or trunnion mounting.

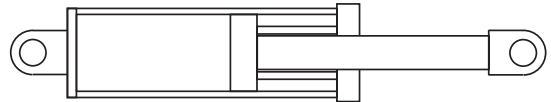

MINIMUM PISTON ROD DIAMETER

Figures in body of chart are suggested minimum rod diameters, in inches.

Load, Pounds	Exposed Length of Piston Rod, Inches / Rod Diameter, Inches							
	10"	20"	40"	60"	70"	80"	100"	120"
1,000			3/4	1				
1,500			13/16	1-1/16				
2,000		5/8	7/8	1-1/8	1-1/4	1-3/8		
3,000		11/16	15/16	1-3/16	1-3/8	1-1/2		
4,000		3/4	1	1-1/4	1-7/16	1-9/16	1-7/8	
6,000	13/16	7/8	1-1/8	1-3/8	1-9/16	1-5/8	1-7/8	
8,000	15/16	1	1-3/16	1-1/2	1-5/8	1-3/4	2	2-1/4
10,000	1	1-1/8	1-5/16	1-9/16	1-3/4	1-7/8	2-1/8	2-3/8
15,000	1-3/16	1-1/4	1-7/16	1-3/4	1-3/4	2	2-1/4	2-1/2
20,000	1-3/8	1-7/16	1-5/8	1-7/8	2	2-1/8	2-7/16	2-3/4
30,000	1-11/16	1-3/4	1-7/8	2-1/8	2-1/4	2-3/8	2-11/16	3
40,000	2	2	2-1/8	2-3/8	2-1/2	2-5/8	2-7/8	3-1/4
60,000	2-3/8	2-7/16	2-1/2	2-3/4	2-3/4	2-7/8	3-1/4	3-1/2
80,000	2-3/4	2-3/4	2-7/8	3	3	3-1/4	3-1/2	3-3/4
100,000	3-1/8	3-1/8	3-1/4	3-3/8	3-1/2	3-1/2	3-3/4	4
150,000	3-3/4	3-3/4	3-7/8	4	4	4-1/8	4-3/8	4-1/2
200,000	4-3/8	4-3/8	4-3/8	4-1/2	4-3/4	4-3/4	4-7/8	5
300,000	5-3/8	5-3/8	5-3/8	5-1/2	5-1/2	5-1/2	5-3/4	6

Cylinder Working a Rotating Lever:

A cylinder working a hinged lever can exert its maximum force on the lever only when the lever axis and cylinder axis are at right angles. When Angle "A" is greater or less than a right angle, only part of the cylinder force is effective on the lever. The cylinder force is found by multiplying the full cylinder force times the sine (sin) of the least angle between cylinder and lever axes. Cylinder Force, FF, is horizontal in this figure. Only that portion, EF, which is at right angles to the lever axis is effective for turning the lever. The value of EF varies with the acute angle "A" between the cylinder and lever axis.

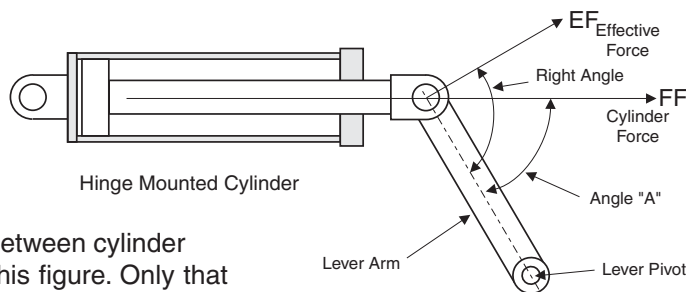

Example: Find the effective force exerted by a 3-inch bore cylinder against a lever when the cylinder is operating at 3000 PSI and when its axis is at an angle of 55 degrees with the lever axis.

First, find the full force developed by the cylinder: FF (full force) = 7.07 (piston area) x 3000 PSI = 21,210 lbs. Next, find the effective force at 55°: EF (effective force) = 21,210 x 819 (sin 55°) = 17,371 lbs.

Since maximum cylinder force is delivered in the right angle position, the hinge points for the cylinder and lever should be located, if possible, so the right angle falls close to the lever position which requires the greatest torque (force).

Note: The working angles on a hinged units, such as a dump truck, refuse body packer blade, or a crane, are constantly changing, it may be necessary to construct a rough model on a sheet of paper, to exact scale, with cardboard arms and thumbtack hinge pins. This will show the point at which the greatest cylinder thrust is needed. An exact calculation can then be made for this condition.

POWER FACTOR TABLE
Trigonometric Sines and Cosines

Angle, Degrees	Sine (sin)	Cosine (cos)	Angle, Degrees	Sine (sin)	Cosine (cos)	Angle, Degrees	Sine (sin)	Cosine (cos)
1	0.0175	0.9998	31	0.5150	0.8572	61	0.8746	0.4848
2	0.0349	0.9994	32	0.5299	0.8480	62	0.8829	0.4695
3	0.0523	0.9986	33	0.5446	0.8387	63	0.8910	0.4540
4	0.0698	0.9976	34	0.5592	0.8290	64	0.8988	0.4384
5	0.0872	0.9962	35	0.5736	0.8192	65	0.9063	0.4226
6	0.1045	0.9945	36	0.5878	0.8090	66	0.9135	0.4067
7	0.1219	0.9925	37	0.6018	0.7986	67	0.9205	0.3907
8	0.1392	0.9903	38	0.6157	0.7880	68	0.9272	0.3746
9	0.1564	0.9877	39	0.6293	0.7771	69	0.9336	0.3584
10	0.1736	0.9848	40	0.6428	0.7660	70	0.9397	0.3420
11	0.1908	0.9816	41	0.6561	0.7547	71	0.9455	0.3256
12	0.2079	0.9781	42	0.6691	0.7431	72	0.9511	0.3090
13	0.2250	0.9744	43	0.6820	0.7314	73	0.9563	0.2924
14	0.2419	0.9703	44	0.6947	0.7193	74	0.9613	0.2756
15	0.2588	0.9659	45	0.7071	0.7071	75	0.9659	0.2588
16	0.2756	0.9613	46	0.7193	0.6947	76	0.9703	0.2419
17	0.2924	0.9563	47	0.7314	0.6820	77	0.9744	0.2250
18	0.3090	0.9511	48	0.7431	0.6691	78	0.9781	0.2079
19	0.3256	0.9455	49	0.7547	0.6561	79	0.9816	0.1908
20	0.3420	0.9397	50	0.7660	0.6428	80	0.9848	0.1736
21	0.3584	0.9336	51	0.7771	0.6293	81	0.9877	0.1564
22	0.3746	0.9272	52	0.7880	0.6157	82	0.9903	0.1392
23	0.3907	0.9205	53	0.7986	0.6018	83	0.9925	0.1219
24	0.4067	0.9135	54	0.8090	0.5878	84	0.9945	0.1045
25	0.4226	0.9063	55	0.8192	0.5736	85	0.9962	0.0872
26	0.4384	0.8988	56	0.8290	0.5592	86	0.9976	0.0698
27	0.4540	0.8910	57	0.8387	0.5446	87	0.9986	0.0523
28	0.4695	0.8829	58	0.8480	0.5299	88	0.9994	0.0349
29	0.4848	0.8746	59	0.8572	0.5150	89	0.9998	0.0175
30	0.5000	0.8660	60	0.8660	0.5000	90	1	0

Cylinders on Cranes and Beams:

Example 1: Calculation to find cylinder force required to handle 15,000 lbs. when the beam is in the position shown.

First find the force F2 at right angles to the beam which must be present to support the 15,000 lb. load.

$$F2 = W \times \cos 50^\circ = 15,000 \times .643 = 9,645 \text{ lbs.}$$

Next, find the force F1, also at right angles to the beam, which must be produced by the cylinder to support the 15,000 lb. load. This is calculated by proportion. F1 will be greater than F2 in the same ratio that arm length 17 feet is greater than arm length 5 feet.

$$\text{Arm length ratio of } 17 \div 5 = 3.4.$$

Therefore, $F1 = 9,645 \times 3.4 = 32,793 \text{ lbs.}$

Finally, calculate the cylinder force, at an angle of 30° to the beam, which will produce a force of 32,793 lbs. at its rod hinge point at right angles to the beam.

$$F \text{ (cylinder force)} = F1 \div \sin 30^\circ = 32,793 \div .500 = 65,586 \text{ lbs.}$$

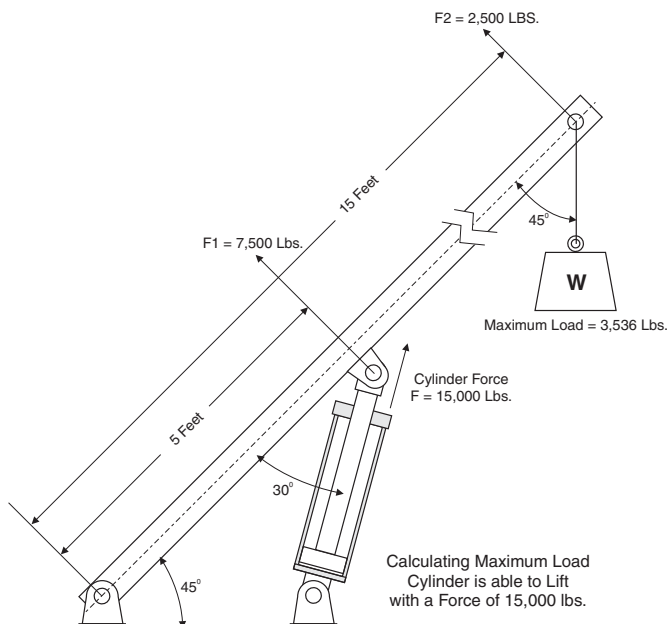
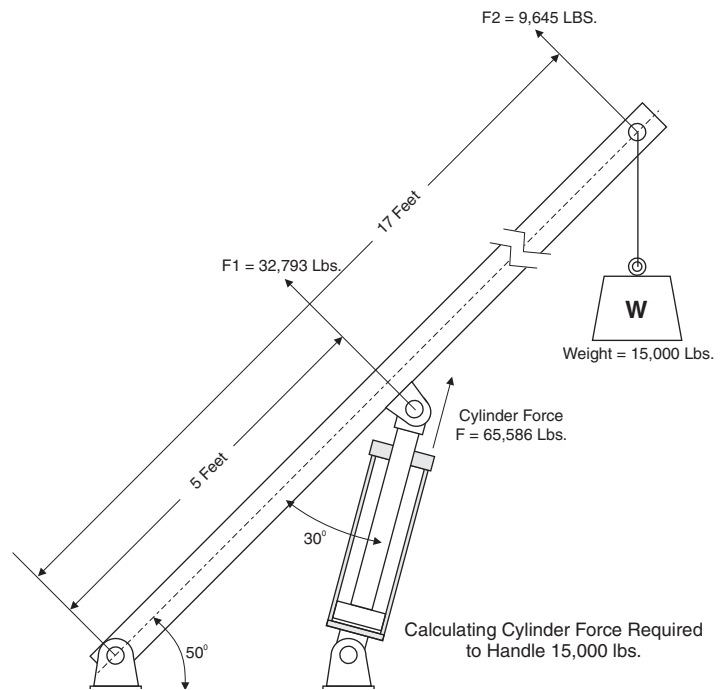

Example 2: Calculation to find maximum load that can be lifted with a cylinder force of 15,000 lbs. when the beam is in the position shown.

First, translate the cylinder thrust, F, of 15,000 lbs. into 7,500 lbs. at right angles to the beam using power factor of 0.500 (sin) from the power factor table, for a 30° angle.

Next, translate this to F2, 2,500 lbs. at the end of beam where the weight is suspended. This is done with simple proportion by the length of each arm from the base pivot point. F2 is 1/3rd F1 since the lever arm is 3 times as long.

Finally, find the maximum hanging load that can be lifted, at a 45° angle between beam and load weight, using sin (power factor) for 45° :

$$W = F2 \div \sin 45^\circ = 2500 \div 0.707 = 3535 \text{ lbs.}$$

Calculations for a Heavy Beam:

On a heavy beam it is necessary to calculate not only for concentrated loads such as the suspended weights and cylinder thrust, but to figure in the weight of the beam itself. If the beam is uniform, so many pounds per foot of length, the calculation is relatively easy. In the example shown in figure "B", the beam has a uniform weight of 150 lbs. per foot, is partially counterbalanced by a weight of 500 lbs. on the left side of the fulcrum, and must be raised by the force of a cylinder applied at a point 9 feet from the right side of the fulcrum.

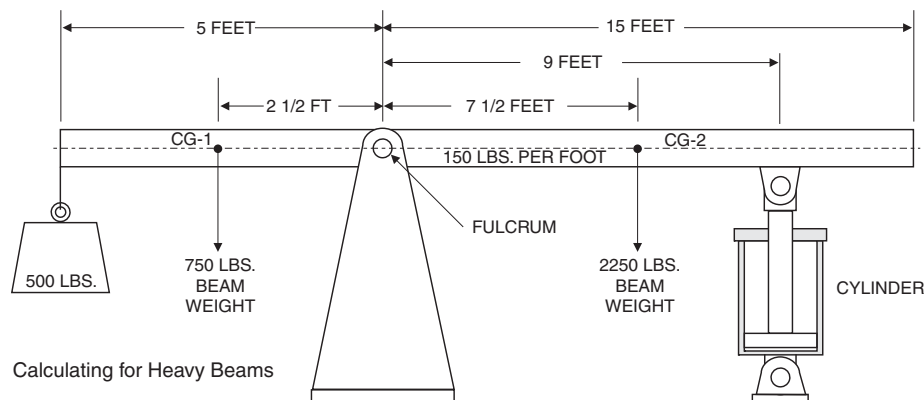

foot, is partially counterbalanced by a weight of 500 lbs. on the left side of the fulcrum, and must be raised by the force of a cylinder applied at a point 9 feet from the right side of the fulcrum.

The best method of solution is to use the principle of moments. A moment is a torque force consisting of (so many) pounds applied at a lever distance of (so many) feet or inches. The solution here is to find how much cylinder thrust is needed to just balance the beam. Then, by increasing the hydraulic cylinder

thrust 5 to 10% to take care of friction losses, the cylinder would be able to raise the beam.

Using the principle of moments, it is necessary to calculate all of the moment forces which are trying to turn the beam clockwise, then calculate all the moment forces trying to turn the beam counter-clockwise, then subtract the two. In this case they must be equal to balance the beam.

Clockwise moment due to the 15 feet of beam on the right side of the fulcrum: This can be considered as a concentrated weight acting at its center of gravity 7 1/2 feet from the fulcrum. $\text{Moment} = 150 \text{ (lbs. per foot)} \times 15 \text{ feet} \times 7 \frac{1}{2} \text{ feet} = 16,875 \text{ foot pounds.}$

Counter-clockwise moment due to the 5 feet of beam on the left side of the fulcrum: $150 \text{ (lbs. per foot)} \times 5 \text{ feet} \times 2 \frac{1}{2} \text{ feet (CG distance)} = 1875 \text{ foot pounds.}$

Counter-clockwise moment due to hanging weight of 500 pounds: $500 \times 5 \text{ feet} = 2500 \text{ foot lbs.}$

Subtracting counter-clockwise from clockwise moments: $16,875 - 1875 - 2500 = 12,500 \text{ foot pounds}$ that must be supplied by the cylinder for balance condition. To find cylinder thrust: $12,500 \text{ foot pounds} \div 9 \text{ feet (distance from fulcrum)} = 1388.8 \text{ pounds.}$

Remember when working with moments, that only the portion of the total force which is at right angles to the beam is effective as a moment force. If the beam is at an angle to the cylinder or to the horizontal, then the effective portion of the concentrated or distributed weight, and the cylinder thrust, can be calculated with the power factors (refer to chart).

Cylinder Force

Theoretical Push and Pull Forces for Hydraulic Cylinders

(values do not reflect losses due to friction or other variables)

$$\text{Force (lb)} = \text{Pressure (psi)} \times \text{Piston Area (sq.in.)}$$

Push Force and Displacement

Cyl. Bore Size (Inches)	Piston Area (Sq. In.)	Cylinder Push Stroke Force In Pounds At Various Pressures										
		250	500	750	1000	1500	2000	2500	3000	3500	4000	5000
2.00	3.14	785	1570	2355	3140	4710	6280	7850	9420	10990	12560	15700
2.50	4.91	1228	2455	3683	4910	7365	9820	12275	14730	17185	19640	24550
3.00	7.07	1768	3535	5303	7070	10605	14140	17675	21210	24745	28280	35350
3.25	8.30	2075	4150	6225	8300	12450	16600	20750	24900	29050	33200	41500
3.50	9.62	2405	4810	7215	9620	14430	19240	24050	28860	33670	38480	48100
4.00	12.57	3143	6285	9428	12570	18855	25140	31425	37710	43995	50280	62850
4.50	15.90	3975	7950	11925	15900	23850	31800	39750	47700	55650	63600	79500
5.00	19.64	4910	9820	14730	19640	29460	39280	49100	58920	68740	78560	98200
5.50	23.76	5940	11880	17820	23760	35640	47520	59400	71280	83160	95040	118800
6.00	28.27	7068	14135	21203	28270	42405	56540	70675	84810	98945	113080	141350
7.00	38.49	9623	19245	28868	38490	57735	76980	96225	115470	134715	153960	192450
8.00	50.27	12568	25135	37703	50270	75405	100540	125675	150810	175945	201080	251350

Deductions for Pull Force and Displacement

Piston Rod Dia. (Inches)	Rod Area (Sq. In.)	Piston Rod Diameter Force In Pounds At Various Pressures										
		To determine Cylinder Pull Force or Displacement, deduct the following Force or Displacement corresponding to Rod Size, from selected Push Stroke Force or Displacement corresponding to Bore Size in table above.										
		250	500	750	1000	1500	2000	2500	3000	3500	4000	5000
1.00	.785	196	393	589	785	1178	1570	1963	2355	2748	3140	3925
1.125	.994	249	497	746	994	1491	1988	2485	2982	3479	3976	4970
1.25	1.23	308	615	923	1230	1845	2460	3075	3690	4305	4920	6150
1.375	1.49	373	745	1118	1490	2235	2980	3725	4470	5215	5960	7450
1.50	1.77	443	885	1328	1770	2655	3540	4425	5310	6195	7080	8850
1.75	2.41	603	1205	1808	2410	3615	4820	6025	7230	8435	9640	12050
2.00	3.14	785	1570	2355	3140	4710	6280	7850	9420	10990	12560	15700
2.25	3.98	995	1990	2985	3980	5970	7960	9950	11940	13930	15920	19900
2.50	4.91	1228	2455	3683	4910	7365	9820	12275	14730	17185	19640	24550
2.75	5.94	1485	2970	4455	5940	8910	11880	14850	17820	20790	23760	29700
3.00	7.07	1768	3535	5303	7070	10605	14140	17675	21210	24745	28280	35350
3.50	9.62	2405	4810	7215	9620	14430	19240	24050	28860	33670	38480	48100
4.00	12.57	3143	6285	9428	12570	18855	25140	31425	37710	43995	50280	62850
4.50	15.90	3975	7950	11925	15900	23850	31800	39750	47700	55650	63600	79500

THEORETICAL CYLINDER SPEEDS (inches per second)

Speed (in/sec) = 3.85 x Flow (GPM) ÷ Area (sq.in.)

Bore Size	Rod Size	Flow (GPM)															
		1	2	5	7	10	12	15	20	25	30	35	40	45	50	60	70
2.00		1.2	2.5	6.1	8.6	12.3	14.7	18.4									
	1.00	1.6	3.3	8.2	11.4	16.4	19.6	24.5									
	1.125	1.8	3.6	9.0	12.6	17.9	21.5	26.9									
	1.25	2.0	4.0	10.1	14.1	20.2	24.2	30.2									
	1.375	2.3	4.7	11.6	16.3	23.3	27.9	34.9									
2.50	1.50	2.8	5.6	14.1	19.7	28.1	33.7	42.2									
		0.8	1.6	3.9	5.5	7.9	9.4	11.8	15.7	19.6							
	1.00	0.9	1.9	4.7	6.5	9.3	11.2	14.0	18.7	23.5							
	1.125	1.0	2.0	4.9	6.9	9.8	11.8	14.7	19.7	24.6							
	1.25	1.0	2.1	5.2	7.3	10.5	12.6	15.7	20.9	26.2							
	1.375	1.1	2.3	5.6	7.9	11.3	13.5	16.9	22.5	28.1							
	1.50	1.2	2.5	6.1	8.6	12.3	14.7	18.4	24.5	30.7							
3.00	1.75	1.5	3.1	7.7	10.8	15.4	18.5	23.1	30.8	38.5							
	2.00	2.2	4.4	10.9	15.2	21.8	26.1	32.6	43.5	54.4							
		0.5	1.1	2.7	3.8	5.5	6.5	8.2	10.9	13.6	16.4	19.1					
	1.00	0.6	1.2	3.1	4.3	6.1	7.4	9.2	12.3	15.3	18.4	21.4					
	1.125	0.6	1.3	3.2	4.4	6.3	7.6	9.5	12.7	15.8	19.0	22.2					
	1.25	0.7	1.3	3.3	4.6	6.6	7.9	9.9	13.2	16.5	19.8	23.1					
	1.375	0.7	1.4	3.5	4.8	6.9	8.3	10.4	13.8	17.3	20.7	24.2					
	1.50	0.7	1.5	3.6	5.1	7.3	8.7	10.9	14.5	18.2	21.8	25.4					
	1.75	0.8	1.7	4.1	5.8	8.3	9.9	12.4	16.5	20.7	24.8	28.9					
3.25	2.00	1.0	2.0	5.0	6.9	9.8	11.8	14.7	19.6	24.5	29.4	34.3					
		0.5	0.9	2.3	3.3	4.6	5.6	7.0	9.3	11.6	13.9	16.3	18.6				
	1.25	0.5	1.1	2.7	3.8	5.4	6.5	8.2	10.9	13.6	16.3	19.1	21.8				
	1.375	0.6	1.1	2.8	3.9	5.7	6.8	8.5	11.3	14.1	17.0	19.8	22.6				
	1.50	0.6	1.2	2.9	4.1	5.9	7.1	8.8	11.8	14.7	17.7	20.6	23.6				
	1.75	0.7	1.3	3.3	4.6	6.5	7.9	9.8	13.1	16.4	19.6	22.9	26.2				
	2.00	0.8	1.5	3.7	5.2	7.5	9.0	11.2	15.0	18.7	22.4	26.1	29.9				
3.50		0.4	0.8	2.0	2.8	4.0	4.8	6.0	8.0	10.0	12.0	14.0	16.0	18.0			
	1.25	0.5	0.9	2.3	3.2	4.6	5.5	6.9	9.2	11.5	13.8	16.1	18.4	20.6			
	1.375	0.5	0.9	2.4	3.3	4.7	5.7	7.1	9.5	11.8	14.2	16.6	18.9	21.3			
	1.50	0.5	1.0	2.5	3.4	4.9	5.9	7.4	9.8	12.3	14.7	17.2	19.6	22.1			
	1.75	0.5	1.1	2.7	3.7	5.3	6.4	8.0	10.7	13.4	16.0	18.7	21.4	24.0			
	2.00	0.6	1.2	3.0	4.2	5.9	7.1	8.9	11.9	14.7	17.8	20.8	23.8	26.8			
	2.50	0.8	1.6	4.1	5.7	8.2	9.8	12.3	16.4	20.4	24.5	28.6	32.7	36.8			
4.00			0.6	1.5	2.2	3.1	3.7	4.6	6.1	7.7	9.2	10.7	12.3	13.8	15.3	18.4	
	1.375		0.7	1.7	2.4	3.5	4.2	5.2	6.9	8.7	10.4	12.2	13.9	15.6	17.4	20.8	
	1.50		0.7	1.8	2.5	3.6	4.3	5.3	7.1	8.9	10.7	12.5	14.3	16.0	17.8	21.4	
	1.75		0.8	1.9	2.7	3.8	4.6	5.7	7.6	9.5	11.4	13.3	15.2	17.1	19.0	22.8	
	2.00		0.8	2.0	2.9	4.1	4.9	6.1	8.2	10.2	12.3	14.3	16.4	18.4	20.4	24.5	
	2.50		1.0	2.5	3.5	5.0	6.0	7.5	10.1	12.6	15.1	17.6	20.1	22.6	25.1	30.2	
	3.00		1.4	3.5	4.9	7.0	8.4	10.5	14.0	17.5	21.0	24.5	28.0	31.5	35.0	42.0	
	4.50		0.5	1.2	1.7	2.4	2.9	3.6	4.8	6.1	7.3	8.5	9.7	10.9	12.1	14.5	17.0
1.75			0.6	1.4	2.0	2.9	3.4	4.3	5.7	7.1	8.6	10.0	11.4	12.8	14.3	17.1	20.0
2.00			0.6	1.5	2.1	3.0	3.6	4.5	6.0	7.6	9.1	10.6	12.1	13.6	15.1	18.1	21.1
2.50			0.7	1.8	2.5	3.5	4.2	5.3	7.0	8.8	10.5	12.3	14.0	15.8	17.5	21.0	24.5
3.00			0.9	2.2	3.1	4.4	5.2	6.5	8.7	10.9	13.1	15.3	17.4	19.6	21.8	26.2	30.5
3.50			1.2	3.1	4.3	6.1	7.4	9.2	12.3	15.3	18.4	21.5	24.5	27.6	30.7	36.8	42.9
5.00		0.4	1.0	1.4	2.0	2.4	2.9	3.9	4.9	5.9	6.9	7.9	8.8	9.8	11.8	13.7	
	2.00		0.5	1.2	1.6	2.3	2.8	3.5	4.7	5.8	7.0	8.2	9.3	10.5	11.7	14.0	16.4
	2.50		0.5	1.3	1.8	2.6	3.1	3.9	5.2	6.5	7.8	9.1	10.5	11.8	13.1	15.7	18.3
	3.00		0.6	1.5	2.2	3.1	3.7	4.6	6.1	7.7	9.2	10.7	12.3	13.8	15.3	18.4	21.5
	3.50		0.8	1.9	2.7	3.9	4.6	5.8	7.7	9.6	11.5	13.5	15.4	17.3	19.2	23.0	26.9
	4.00		1.1	2.7	3.8	5.4	6.5	8.2	10.9	13.6	16.3	19.1	21.8	24.5	27.2	32.7	38.1
5.50			0.8	1.1	1.6	1.9	2.4	3.2	4.1	4.9	5.7	6.5	7.3	8.1	9.7	11.3	
	2.50		1.0	1.4	2.0	2.5	3.1	4.1	5.1	6.1	7.1	8.2	9.2	10.2	12.3	14.3	
	3.00		1.2	1.6	2.3	2.8	3.5	4.6	5.8	6.9	8.1	9.2	10.4	11.5	13.8	16.1	
	3.50		1.4	1.9	2.7	3.3	4.1	5.4	6.8	8.2	9.5	10.9	12.3	13.6	16.3	19.1	
	4.00		1.7	2.4	3.4	4.1	5.2	6.9	8.6	10.3	12.0	13.8	15.5	17.2	20.6	24.1	
	4.50		2.4	3.4	4.9	5.9	7.3	9.8	12.2	14.7	17.1	19.6	22.0	24.5	29.4	34.3	
6.00			0.7	1.0	1.4	1.6	2.0	2.7	3.4	4.1	4.8	5.5	6.1	6.8	8.2	9.5	
	2.50		0.8	1.2	1.7	2.0	2.5	3.3	4.1	5.0	5.8	6.6	7.4	8.2	9.9	11.5	
	3.00		0.9	1.3	1.8	2.2	2.7	3.6	4.5	5.5	6.4	7.3	8.2	9.1	10.9	12.7	
	3.50		1.0	1.4	2.1	2.5	3.1	4.1	5.2	6.2	7.2	8.3	9.3	10.3	12.4	14.5	
	4.00		1.2	1.7	2.5	2.9	3.7	4.9	6.1	7.4	8.6	9.8	11.0	12.3	14.7	17.2	
	4.50		1.6	2.2	3.1	3.7	4.7	6.2	7.8	9.3	10.9	12.4	14.0	15.6	18.7	21.8	
7.00			0.5	0.7	1.0	1.2	1.5	2.0	2.5	3.0	3.5	4.0	4.5	5.0	6.0	7.0	
	2.50		0.6	0.8	1.1	1.4	1.7	2.3	2.9	3.4	4.0	4.6	5.2	5.7	6.9	8.0	
	3.00		0.6	0.9	1.2	1.5	1.8	2.5	3.1	3.7	4.3	4.9	5.5	6.1	7.4	8.6	
	3.50		0.7	0.9	1.3	1.6	2.0	2.7	3.3	4.0	4.7	5.3	6.0	6.7	8.0	9.3	
	4.00		0.7	1.0	1.5	1.8	2.2	3.0	3.7	4.5	5.2	5.9	6.7	7.4	8.9	10.4	
	4.50		0.9	1.2	1.7	2.0	2.6	3.4	4.3	5.1	6.0	6.8	7.7	8.5	10.2	11.9	
8.00				0.5	0.8	0.9	1.2	1.5	1.9	2.3	2.7	3.1	3.5	3.8	4.6	5.4	
	3.50			0.7	1.0	1.1	1.4	1.9	2.4	2.8	3.3	3.8	4.3	4.7	5.7	6.6	
	4.00			0.7	1.0	1.2	1.5	2.0	2.6	3.1	3.6	4.1	4.6	5.1	6.1	7.2	
	4.50			0.8	1.1	1.3	1.7	2.2	2.8	3.4	3.9	4.5	5.0	5.6	6.7	7.8	

Hydraulic Oil Recommendations

All cylinder parts, with the exception of a few items, are lubricated by the hydraulic oil in the circuit. Particular attention must be paid to keep the oil in the circuit clean. Whenever there is a hydraulic component failure (cylinder, pump, valve), and there is a reason to feel that metal particles may be in the system, the oil must be drained, the entire system flushed clean, and any filter screens thoroughly cleaned or replaced. New oil should be supplied for the entire system. Oil suitable and recommended for use in circuits involving Commercial cylinders should meet the following specifications:

***These suggestions are intended as a guide only.
Obtain your final oil recommendations from your oil supplier.***

Viscosity Recommendations:

Optimum operating viscosity is considered to be about 100 SSU.

- * 50 SSU minimum @ operating temperature
7500 SSU maximum @ starting temperature
- * 150 to 225 SSU @ 100° F. (37.8° C.) (generally)
44 to 48 SSU @ 210° F. (98.9° C.) (generally)

Other Desirable Properties:

Viscosity Index: 90 minimum
Aniline point: 175 minimum

Additives Usually Recommended:

Rust and Oxidation (R & O) Inhibitors
Foam Depressant

Other Desirable Characteristics:

Stability of physical and chemical characteristics.
High demulsibility (low emulsibility) for separation of water, air and contaminants.
Resistant to the formation of gums, sludges, acids, tars and varnishes.
High lubricity and film strength.

General Recommendations:

A good quality hydraulic oil conforming to the characteristics listed above is essential to the satisfactory performance and long life of any hydraulic system.

Oil should be changed on regular schedules in accordance with the manufactures recommendations and the system periodically flushed.

Oil operating temperature should not exceed 200° F. (93° C.) with a maximum of 180° F. (82° C.) generally recommended. 120° F. to 140° F. (50° C. to 60° C.) is generally considered optimum. High temperatures result in rapid oil deterioration and may point out a need for an oil cooler or a larger reservoir. The nearer to optimum temperature, the longer the service life of the oil and the hydraulic components.

Reservoir size should be large enough to hold and cool all the fluid a system will need, yet it should not be wastefully large. Minimum required capacity can vary anywhere between 1 and 3 times pump output. The reservoir must be able to hold all of the fluid displaced by retracted cylinders when the system is not operating, yet provide space for expansion and foaming.

Oil poured into the reservoir should pass through a 100 mesh screen. Pour only clean oil from clean containers into the reservoir.

Never use Crank Case Drainings, Kerosene, Fuel Oil, or any Non-Lubricating Fluid, such as Water.

Approximate SSU at . . .

Oil Grade	100° F. (37.8° C.)	210° F. (98.9° C.)
SAE 10	150	43
SAE 20	330	51

Normal Temperatures:

0° F. (-18° C.) to 100° F. (37.8° C.) ambient
100° F. (37.8° C.) to 180° F. (82.2° C.) system

Be sure the oil you use is recommended for the temperature you expect to encounter.

Hydraulic Cylinder Formulas

CYLINDER FORMULAS

Thrust or force of any cylinder:

$$F = A \times P$$

$$P = F \div A$$

$$A = F \div P$$

F = Force or thrust, in pounds

A = Piston area in square inches ($.7854 \times D^2$)

P = PSI (Gauge pressure in pounds per square inch)

$$\text{HP} = \frac{\text{Pounds of push (or pull)} \times \text{Distance (in feet)}}{550 \times \text{Time (in seconds)}}$$

HP = Horsepower

Circle Formula:

$$A = D \times D \times .7854$$

$$A = D^2 \times 0.7854$$

$$A = \pi \times R^2$$

$$A = \pi \times D^2 \div 4$$

$$\text{Circumference} = 2 \times R \times \pi$$

$$\text{Circumference} = \pi \times D$$

$$D = \sqrt{A/.7854}$$

A = Area in² (Area sq. in.)

R = Radius (1/2 of Diameter)

D = Diameter, inches

$\pi = 3.14$

Hydraulic Cylinder Piston travel speed:

$$V1 \text{ (in/min)} = \text{CIM} \div A$$

$$V2 \text{ (ft/min)} = Q \times 19.25 \div A$$

$$V3 \text{ (ft/sec)} = Q \times 0.3208 \div A$$

$$Q \text{ (GPM)} = 3.117 \times V3 \text{ (ft/sec)} \times A$$

$$Q \text{ (GPM)} = \text{CIM} \div 231$$

V1 = Velocity or piston travel speed, inches per minute

V2 = Velocity or piston travel speed, feet per minute

V3 = Velocity or piston travel speed, feet per second

CIM = Flow rate in cubic inches per minute (in³)

A = Effective area in square inches (in²)

Q = GPM Gallons per minute

1 Gallon = 231 in³ (cubic inch)

Volume required to move a piston a given distance:

$$V = A \times L$$

V = Volume in cubic inches (in³)

A = Area in square inches (in²)

L = Length or stroke in inches

Regenerative Cylinder

$$\text{Extend Speed} = \frac{\text{Rod Volume}}{\text{Flow Rate}} \text{ in}^3$$

$$\text{Area to Retract} = \text{Area to extend} - \text{Rod Area}$$

$$\text{Cylinder Ratio} = \frac{\text{Area to extend}}{\text{Area to retract}}$$

Note:

Ratio can be used to calculate pressure intensification and flow intensification.

Effective force of a cylinder working at an angle to direction of the load travel:

$$F = T \times \sin A$$

T = Total cylinder force, in pounds

F = Part of the force which is effective, in pounds

A = Least angle, in degrees, between cylinder axis and load direction.

Moment Arm Equations / Levers:

$$F \times D_f = W \times D_w$$

$$F = \frac{W \times D_w}{D_f}$$

$$W = \frac{F \times D_f}{D_w}$$

$$D_f = \frac{W \times D_w}{F}$$

$$D_w = \frac{F \times D_f}{W}$$

F = Cylinder force

Df = Cylinder force distance to pivot

W = Weight or Load Force

Dw = Weight or Load Force distance to pivot

Toggle Force:

$$T = \frac{F \times A}{2 \times B}$$

T = Toggle Force

F = Cylinder Force

A = Distance cylinder centerline to toggle

B = Remaining stroke

Force for piercing or shearing sheet metal:

$$F = P \times T \times \text{PSI}$$

F = Force required, in pounds

P = Perimeter around area to be sheared, in inches

T = Sheet thickness in inches

PSI = Sheer strength rating of the material in pounds per square inch.

P.O. Check Application:

$$\text{Release PSI} = \frac{\text{Cap End Area} \times \text{Max. W.P.} - \text{Load}}{\text{Rod End Area}}$$

Max. W.P. = Pressure Rating of Components

$$\text{Ratio} = \frac{\text{Max Working PSI}}{\text{Release PSI}}$$

Example;

2 to 1 Ratio = 1 square inch (in²) at 1000 psi working pressure will open when a Release pressure of 500 psi is applied to a 2 square inches (in²) area.

Storage and Installation

STORAGE

It pays to keep spare hydraulic cylinders on hand for use when you need them. But, you must know and follow these recommended storage practices or the cylinders can be ruined. Hydraulic cylinders, though often large and unwieldy, are precision machines with finely finished parts and close tolerances. And they're expensive. So handle them with care.

For optimum storage life, hydraulic cylinders should be kept in an environment that is protected from excessive moisture and temperature extremes. A hot, dry desert climate with cold nights, for example, must be accommodated when choosing the storage area. Daytime heat quickly bakes oil out of sealing materials, which causes leaks and rapid wear when the cylinder is placed in service. Cooling at night causes water condensation and corrosion damage to wear surfaces. Storage areas that allow exposure to rain, snow and extreme cold must like wise be avoided.

It's best to store cylinders indoors if possible. But indoors or out, be sure that plugs or closures are properly installed in all ports to keep out moisture and dirt. However, overtightening of port plugs should be avoided. Widely varying temperatures and tightly closed ports may cause pressure inside the cylinder to build up to the point where the piston moves far enough to expose the rod to corrosion or contamination. Try to choose a storage location where the cylinders are protected from physical damage. Even a little ding from a falling bar or forklift tine can cause trouble later.

Cylinders, Particularly large ones, should be stored closed in a vertical position with the rod end down. Be sure they're blocked securely to keep them from toppling. Storing with the rod ends down keeps oil on the seals, which protects them from drying out. This is more critical with fabric and butyl seals than with urethane sealing materials. Storing single-acting cylinders with the rod end up can cause port closures to pop open and leak, exposing the sleeves to corrosion damage and contamination. Storing with the rod end down also discourages the temptation to lift a cylinder by the rod eye – a dangerous practice. If horizontal storage cannot be avoided, the rod or cylinder should be rolled into a new position every two months or so to prevent drying, distortion and deterioration of the seals. Don't forget that a cylinder can be a major source of contamination. A small scratch or nick on the sleeve will quickly shred packing and contaminate the system. Store cylinders carefully and keep them clean.

The following procedures should be followed in order to prevent oxidation and maintain the surfaces of a mounted hydraulic cylinder during idle periods. These idle periods may include; inventory units, demo units, out of service units, etc.

- All machined surfaces left expose should be coated with a light film of grease, if not oxidation will occur.
- If oxidation is present, apply a light coat of oil to the surfaces.
- Buff surfaces with 320 or 400 grit sandpaper. Do not buff surfaces up and down the length, buff only around the circumference.
- If after buffing, the surfaces show evidence of oxidation damage i.e., pitting, the cylinder should be inspected by an authorized service center for evaluation.
- Operation of a hydraulic cylinder with surface damage will shorten the longevity and preclude any warranty express or implied.

INSTALLATION

- Cleanliness is an important consideration, and Parker cylinders are shipped with the ports plugged to protect them from contaminants entering the ports. These plugs should not be removed until the piping is to be installed. Before making the connection to the cylinder ports, the piping should be thoroughly cleaned to remove all chips or burrs which might have resulted from threading or flaring operations. One small foreign particle can cause premature failure of the cylinder or other hydraulic system components. If oxidation is present, apply a light coat of oil to the surfaces.
- Proper alignment of the cylinder piston rod and its mating component on the machine should be checked in both the extended and retracted positions. Improper alignment will result in excessive rod gland and/or cylinder bore wear.
- Cylinders operating in an environment where air drying material are present such as fast- drying chemicals, paint, or welding splatter, or other hazardous conditions such as excessive heat, should have shields installed to prevent damage to the piston rod and piston rod seals.

Parker Safety Guide for Selecting and Using Hydraulic Cylinders and Their Accessories

WARNING:  FAILURE OR IMPROPER SELECTION OR IMPROPER USE OF CYLINDERS AND THEIR RELATED ACCESSORIES CAN CAUSE DEATH, PERSONAL INJURY AND PROPERTY DAMAGE.

Before selecting or using Parker cylinders or related accessories, it is important that you read, understand and follow the following safety information.

User Responsibility

Due to very wide variety of cylinder applications and cylinder operating conditions, Parker does not warrant that any particular cylinder is suitable for any specific application. This safety guide does not analyze all technical parameters that must be considered in selecting a product. The hydraulic and pneumatic cylinders outlined in this catalog are designed to Parker's design guide lines and do not necessarily meet the design guide lines of other agencies such as American Bureau of Shipping, ASME Pressure Vessel Code etc. The user, through its own analysis and testing, is solely responsible for:

- Making the final selection of the cylinders and related accessories.
- Determining if the cylinders are required to meet specific design requirements as required by the Agency(s) or industry standards covering the design of the user's equipment.
- Assuring that the user's requirements are met, OSHA requirements are met, and safety guidelines from the applicable agencies such as but not limited to ANSI are followed and that the use presents no health or safety hazards.
- Providing all appropriate health and safety warnings on the equipment on which the cylinders are used.

Seals

The seals for the product lines shown in this catalogue are intended for mineral base hydraulic fluids and for the operating temperatures ranges as indicated. The operation of these products with other fluids or at other operating temperatures must be brought to the attention of our engineering department so that proper seals for intended operation may be selected.

The application of cylinders may allow fluids such as cutting fluids, wash down fluids etc. to come in contact with the external area of the cylinder. These fluids may attack the piston rod wiper and or the primary seal and must be taken into account when selecting and specifying seal compounds.

Dynamic seals will wear. The rate of wear will depend on many operating factors. Wear can be rapid if a cylinder is mis-aligned or if the cylinder has been improperly serviced. The user must take seal wear into consideration in the application of cylinders.

Piston Rods

Possible consequences of piston rod failure or separation of the piston rod from the piston include, but are not limited to are:

- Piston rod and or attached load thrown off at high speed.
- High velocity fluid discharge.
- Piston rod extending when pressure is applied in the piston retract mode.

Piston rods or machine members attached to the piston rod may move suddenly and without warning as a consequence of other conditions occurring to the machine such as, but not limited to:

- Unexpected detachment of the machine member from the piston rod.
- Failure of the pressurized fluid delivery system (hoses, fittings, valves, pumps, compressors) which maintain cylinder position.
- Catastrophic cylinder seal failure leading to sudden loss of pressurized fluid.
- Failure of the machine control system.

Part of selecting cylinders for a specific operation involves the proper selection of the piston rod diameter. This catalogue contains informa-

tion in the selection of piston rod diameter, which must be followed in order to avoid possible buckling.

Piston rods are not normally designed to absorb bending moments or loads which are perpendicular to the axis of piston rod motion. These additional loads can cause the piston rod to fail. If these types of additional loads are expected to be imposed on the piston rod, their magnitude should be made known to our engineering department.

The cylinder user should always make sure that the piston rod is securely attached to the machine member.

Cushions

Cushions are devices internal to the cylinder to slow the piston and rod assembly down at the end of the stroke. It is suggested they be used to reduce piston impact at the end of the cylinder stroke when the cylinder is expected to move at relatively high velocity.

Cylinder cushions are normally designed to absorb the energy of a linear applied load. A rotating mass has considerably more energy than the same mass moving in a linear mode. Cushioning for a rotating mass application should be review by our engineering department.

Cylinder Mountings

Some cylinder mounting configurations may have certain limitations such as but not limited to minimum stroke for side or foot mounting cylinders or pressure de-ratings for certain flange mounts. Carefully review the catalog for these types of restrictions.

Always mount cylinders using the largest possible high tensile alloy steel socket head cap screws that can fit in the cylinder mounting holes and torque them to the manufacturer's recommendations for their size.

Port Fittings

Hydraulic cylinders applied with meter out or deceleration circuits are subject to intensified pressure at piston rod end.

The rod end pressure is approximately equal to:

$$\frac{\text{operating pressure} \times \text{effective cap end area}}{\text{effective rod end piston area}}$$

Contact your connector supplier for the pressure rating of individual connectors.

Cylinder Modifications or Repairs

Cylinders as shipped from the factory are not to be disassembled and or modified. If cylinders require modifications, these modifications must be done at Parker locations or by Parker certified facilities. The Mobile Cylinder Division Engineering Department must be notified in the event of a mechanical fracture or permanent deformation of any cylinder component (excluding seals). This includes a broken piston rod, mounting accessory or any other cylinder component. This notification should include all operation and application details. This information will be used to provide an engineered repair that will prevent recurrence of the failure. It is allowed to disassemble cylinders for the purpose of replacing seals or seal assemblies.

Offer of Sale

The items described in this document and other documents and descriptions provided by Parker Hannifin Corporation, its subsidiaries and its authorized distributors ("Seller") are hereby offered for sale at prices to be established by Seller. This offer and its acceptance by any customer ("Buyer") shall be governed by all of the following Terms and Conditions. Buyer's order for any item described in its document, when communicated to Seller verbally, or in writing, shall constitute acceptance of this offer. All goods or work described will be referred to as "Products".

- 1. Terms and Conditions.** Seller's willingness to offer Products, or accept an order for Products, to or from Buyer is expressly conditioned on Buyer's assent to these Terms and Conditions and to the terms and conditions found on-line at www.parker.com/saleterms/. Seller objects to any contrary or additional term or condition of Buyer's order or any other document issued by Buyer.
- 2. Price Adjustments; Payments.** Prices stated on the reverse side or preceding pages of this document are valid for 30 days. After 30 days, Seller may change prices to reflect any increase in its costs resulting from state, federal or local legislation, price increases from its suppliers, or any change in the rate, charge, or classification of any carrier. The prices stated on the reverse or preceding pages of this document do not include any sales, use, or other taxes unless so stated specifically. Unless otherwise specified by Seller, all prices are F.O.B. Seller's facility, and payment is due 30 days from the date of invoice. After 30 days, Buyer shall pay interest on any unpaid invoices at the rate of 1.5% per month or the maximum allowable rate under applicable law.
- 3. Delivery Dates; Title and Risk; Shipment.** All delivery dates are approximate and Seller shall not be responsible for any damages resulting from any delay. Regardless of the manner of shipment, title to any products and risk of loss or damage shall pass to Buyer upon tender to the carrier at Seller's facility (*i.e.*, when it's on the truck, it's yours). Unless otherwise stated, Seller may exercise its judgment in choosing the carrier and means of delivery. No deferment of shipment at Buyers' request beyond the respective dates indicated will be made except on terms that will indemnify, defend and hold Seller harmless against all loss and additional expense. Buyer shall be responsible for any additional shipping charges incurred by Seller due to Buyer's changes in shipping, product specifications or in accordance with Section 13, herein.
- 4. Warranty.** Seller warrants that the Products sold hereunder shall be free from defects in material or workmanship for a period of eighteen months from the date of delivery to Buyer. The prices charged for Seller's products are based upon the exclusive limited warranty stated above, and upon the following disclaimer: **DISCLAIMER OF WARRANTY: THIS WARRANTY COMPRISES THE SOLE AND ENTIRE WARRANTY PERTAINING TO PRODUCTS PROVIDED HEREUNDER. SELLER DISCLAIMS ALL OTHER WARRANTIES, EXPRESS AND IMPLIED, INCLUDING MERCHANTABILITY AND FITNESS FOR A PARTICULAR PURPOSE.**
- 5. Claims; Commencement of Actions.** Buyer shall promptly inspect all Products upon delivery. No claims for shortages will be allowed unless reported to the Seller within 10 days of delivery. No other claims against Seller will be allowed unless asserted in writing within 60 days after delivery or, in the case of an alleged breach of warranty, within 30 days after the date within the warranty period on which the defect is or should have been discovered by Buyer. Any action based upon breach of this agreement or upon any other claim arising out of this sale (other than an action by Seller for any amount due to Seller from Buyer) must be commenced within thirteen months from the date of tender of delivery by Seller or, for a cause of action based upon an alleged breach of warranty, within thirteen months from the date within the warranty period on which the defect is or should have been discovered by Buyer.
- 6. LIMITATION OF LIABILITY.** UPON NOTIFICATION, SELLER WILL, AT ITS OPTION, REPAIR OR REPLACE A DEFECTIVE PRODUCT, OR REFUND THE PURCHASE PRICE. IN NO EVENT SHALL SELLER BE LIABLE TO BUYER FOR ANY SPECIAL, INDIRECT, INCIDENTAL OR CONSEQUENTIAL DAMAGES ARISING OUT OF, OR AS THE RESULT OF, THE SALE, DELIVERY, NON-DELIVERY, SERVICING, USE OR LOSS OF USE OF THE PRODUCTS OR ANY PART THEREOF, OR FOR ANY CHARGES OR EXPENSES OF ANY NATURE INCURRED WITHOUT SELLER'S WRITTEN CONSENT, EVEN IF SELLER HAS BEEN NEGLIGENT, WHETHER IN CONTRACT, TORT OR OTHER LEGAL THEORY. IN NO EVENT SHALL SELLER'S LIABILITY UNDER ANY CLAIM MADE BY BUYER EXCEED THE PURCHASE PRICE OF THE PRODUCTS.
- 7. Contingencies.** Seller shall not be liable for any default or delay in performance if caused by circumstances beyond the reasonable control of Seller.
- 8. User Responsibility.** The user, through its own analysis and testing, is solely responsible for making the final selection of the system and Product and assuring that all performance, endurance, maintenance, safety and warning requirements of the application are met. The user must analyze all aspects of the application and follow applicable industry standards and Product information. If Seller provides Product or system options, the user is responsible for determining that such data and specifications are suitable and sufficient for all applications and reasonably foreseeable uses of the Products or systems.
- 9. Loss to Buyer's Property.** Any designs, tools, patterns, materials, drawings, confidential information or equipment furnished by Buyer or any other items which become Buyer's property, may be considered obsolete and may be destroyed by Seller after two consecutive years have elapsed without Buyer placing an order for the items which are manufactured using such property. Seller shall not be responsible for any loss or damage to such property while it is in Seller's possession or control.
- 10. Special Tooling.** A tooling charge may be imposed for any special tooling, including without limitation, dies, fixtures, molds and patterns, acquired to manufacture Products. Such special tooling shall be and remain Seller's property notwithstanding payment of any charges by Buyer. In no event will Buyer acquire any interest in apparatus belonging to Seller which is utilized in the manufacture of the Products, even if such apparatus has been specially converted or adapted for such manufacture and notwithstanding any charges paid by Buyer. Unless otherwise agreed, Seller shall have the right to alter, discard or otherwise dispose of any special tooling or other property in its sole discretion at any time.
- 11. Buyer's Obligation; Rights of Seller.** To secure payment of all sums due or otherwise, Seller shall retain a security interest in the goods delivered and this agreement shall be deemed a Security Agreement under the Uniform Commercial Code. Buyer authorizes Seller as its attorney to execute and file on Buyer's behalf all documents Seller deems necessary to perfect its security interest. Seller shall have a security interest in, and lien upon, any property of Buyer in Seller's possession as security for the payment of any amounts owed to Seller by Buyer.
- 12. Improper use and Indemnity.** Buyer shall indemnify, defend, and hold Seller harmless from any claim, liability, damages, lawsuits, and costs (including attorney fees), whether for personal injury, property damage, patent, trademark or copyright infringement or any other claim, brought by or incurred by Buyer, Buyer's employees, or any other person, arising out of: (a) improper selection, improper application or other misuse of Products purchased by Buyer from Seller; (b) any act or omission, negligent or otherwise, of Buyer; (c) Seller's use of patterns, plans, drawings, or specifications furnished by Buyer to manufacture Product; or (d) Buyer's failure to comply with these terms and conditions. Seller shall not indemnify Buyer under any circumstance except as otherwise provided.
- 13. Cancellations and Changes.** Orders shall not be subject to cancellation or change by Buyer for any reason, except with Seller's written consent and upon terms that will indemnify, defend and hold Seller harmless against all direct, incidental and consequential loss or damage. Seller may change product features, specifications, designs and availability with notice to Buyer.
- 14. Limitation on Assignment.** Buyer may not assign its rights or obligations under this agreement without the prior written consent of Seller.
- 15. Entire Agreement.** This agreement contains the entire agreement between the Buyer and Seller and constitutes the final, complete and exclusive expression of the terms of the agreement. All prior or contemporaneous written or oral agreements or negotiations with respect to the subject matter are herein merged.
- 16. Waiver and Severability.** Failure to enforce any provision of this agreement will not waive that provision nor will any such failure prejudice Seller's right to enforce that provision in the future. Invalidation of any provision of this agreement by legislation or other rule of law shall not invalidate any other provision herein. The remaining provisions of this agreement will remain in full force and effect.
- 17. Termination.** This agreement may be terminated by Seller for any reason and at any time by giving Buyer thirty (30) days written notice of termination. In addition, Seller may by written notice immediately terminate this agreement for the following: (a) Buyer commits a breach of any provision of this agreement (b) the appointment of a trustee, receiver or custodian for all or any part of Buyer's property (c) the filing of a petition for relief in bankruptcy of the other Party on its own behalf, or by a third party (d) an assignment for the benefit of creditors, or (e) the dissolution or liquidation of the Buyer.
- 18. Governing Law.** This agreement and the sale and delivery of all Products hereunder shall be deemed to have taken place in and shall be governed and construed in accordance with the laws of the State of Ohio, as applicable to contracts executed and wholly performed therein and without regard to conflicts of laws principles. Buyer irrevocably agrees and consents to the exclusive jurisdiction and venue of the courts of Cuyahoga County, Ohio with respect to any dispute, controversy or claim arising out of or relating to this agreement. Disputes between the parties shall not be settled by arbitration unless, after a dispute has arisen, both parties expressly agree in writing to arbitrate the dispute.
- 19. Indemnity for Infringement of Intellectual Property Rights.** Seller shall have no liability for infringement of any patents, trademarks, copyrights, trade dress, trade secrets or similar rights except as provided in this Section. Seller will defend and indemnify Buyer against allegations of infringement of U.S. patents, U.S. trademarks, copyrights, trade dress and trade secrets ("Intellectual Property Rights"). Seller will defend at its expense and will pay the cost of any settlement or damages awarded in an action brought against Buyer based on an allegation that a Product sold pursuant to this Agreement infringes the Intellectual Property Rights of a third party. Seller's obligation to defend and indemnify Buyer is contingent on Buyer notifying Seller within ten (10) days after Buyer becomes aware of such allegations of infringement, and Seller having sole control over the defense of any allegations or actions including all negotiations for settlement or compromise. If a Product is subject to a claim that it infringes the Intellectual Property Rights of a third party, Seller may, at its sole expense and option, procure for Buyer the right to continue using the Product, replace or modify the Product so as to make it non-infringing, or offer to accept return of the Product and return the purchase price less a reasonable allowance for depreciation. Notwithstanding the foregoing, Seller shall have no liability for claims of infringement based on information provided by Buyer, or directed to Products delivered hereunder for which the designs are specified in whole or part by Buyer, or infringements resulting from the modification, combination or use in a system of any Product sold hereunder. The foregoing provisions of this Section shall constitute Seller's sole and exclusive liability and Buyer's sole and exclusive remedy for infringement of Intellectual Property Rights.
- 20. Taxes.** Unless otherwise indicated, all prices and charges are exclusive of excise, sales, use, property, occupational or like taxes which may be imposed by any taxing authority upon the manufacture, sale or delivery of Products.
- 21. Equal Opportunity Clause.** For the performance of government contracts and where dollar value of the Products exceed \$10,000, the equal employment opportunity clauses in Executive Order 11246, VEVRRA, and 41 C.F.R. §§ 60-1.4(a), 60-741.5(a), and 60-250.4, are hereby incorporated.



Parker Hannifin Corporation
6035 Parkland Blvd.
Cleveland, Ohio 44124-4141
Telephone: (216) 896-3000
Fax: (216) 896-4000
www.parker.com

Parker Hannifin Corporation

About Parker Hannifin Corporation

Parker Hannifin is a leading global motion-control company dedicated to delivering premier customer service. A Fortune 500 corporation listed on the New York Stock Exchange (PH), our components and systems comprise over 1,400 product lines that control motion in some 1,000 industrial and aerospace markets. Parker is the only manufacturer to offer its customers a choice of hydraulic, pneumatic, and electromechanical motion-control solutions. Our Company has the largest distribution network in its field, with over 7,500 distributors serving nearly 400,000 customers worldwide.

Parker's Charter

To be a leading worldwide manufacturer of components and systems for the builders and users of durable goods. More specifically, we will design, market and manufacture products controlling motion, flow and pressure. We will achieve profitable growth through premier customer service.

Product Information

North American customers seeking product information, the location of a nearby distributor, or repair services will receive prompt attention by calling the Parker Product Information Center at our toll-free number: 1-800-C-PARKER (1-800-272-7537). In Europe, call 00800-C-PARKER-H (00800-2727-5374).

The Aerospace Group

is a leader in the development, design, manufacture and servicing of control systems and components for aerospace and related high-technology markets, while achieving growth through premier customer service.



The Climate & Industrial Controls Group

designs, manufactures and markets system-control and fluid-handling components and systems to refrigeration, air-conditioning and industrial customers worldwide.



The Fluid Connectors Group

designs, manufactures and markets rigid and flexible connectors, and associated products used in pneumatic and fluid systems.



The Seal Group designs, manufactures and distributes industrial and commercial sealing devices and related products by providing superior quality and total customer satisfaction.



The Hydraulics Group

designs, produces and markets a full spectrum of hydraulic components and systems to builders and users of industrial and mobile machinery and equipment.



The Filtration Group

designs, manufactures and markets quality filtration and clarification products, providing customers with the best value, quality, technical support, and global availability.



The Automation Group is a leading supplier of pneumatic and electromechanical components and systems to automation customers worldwide.



The Instrumentation Group is a global leader in the design, manufacture and distribution of high-quality critical flow components for worldwide process instrumentation, ultra-high-purity, medical and analytical applications.



Parker Hannifin Corporation
Mobile Cylinder Div.
P.O. Box 239
Youngstown, OH 44501-0239
phone (330) 480-8431
fax (330) 480-8432
www.parker.com

