

# Series H Heavy Duty Hydraulic Cylinders

Catalog HY08-AC1314-1/NA  
May 2018



**ATLAS**<sup>TM</sup>  
**CYLINDERS**



Abrasive particulate can cause significant wear to precision components when it enters the cylinder and migrates into the hydraulic system. The Atlas Crown Wiper is extremely effective in keeping contamination out of the cylinder to prevent it from shortening the actuator and system service life. Atlas showcases its commitment to reducing hydraulic system problems with the Crown Wiper. This innovative solution goes a long way toward improving equipment operation, lowering costs, extending component life and machine availability.

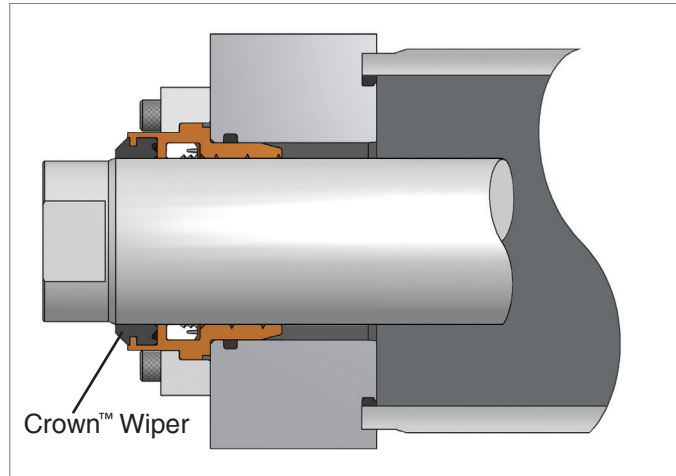

## Product Features:

- The sharp leading edge cleans the piston rod on the retract stroke.
- The Crown Wiper acts as a secondary seal by wiping away any oil film adhering to it on the extended stroke.
- Durable polyurethane material works well for both Seal Class 1 and 4 Service.
- Available in fluorocarbon material for Class 5 service in elevated temperatures.
- Beveled design sheds abrasive contamination away from the bushing.
- Available in rod diameters 0.625" - 5.500".
- Does not change cylinder mounting dimensions.

In line with our policy of continuing product improvement, specifications and information contained in this catalog are subject to change.  
Copyright ©2018 by Parker Hannifin Corporation. All rights reserved.  
PRINTED IN THE U.S.A.

### **WARNING**

**FAILURE OR IMPROPER SELECTION OR IMPROPER USE OF THE PRODUCTS AND/OR SYSTEMS DESCRIBED HEREIN OR RELATED ITEMS CAN CAUSE DEATH, PERSONAL INJURY AND PROPERTY DAMAGE.**

This document and other information from the Parker Hannifin Corporation, its subsidiaries and authorized distributors provide product and/or system options for further investigation by users having expertise. It is important that you analyze all aspects of your application, including consequences of any failure and review the information concerning the product or system in the current product catalog. Due to the variety of operating conditions and applications for these products or systems, the user, through its own analysis and testing, is solely responsible for making the final selection of the products and systems and assuring that all performance, safety and warning requirements of the application are met.

The products described herein, including without limitation, product features, specifications, designs, availability and pricing, are subject to change by Parker Hannifin Corporation and its subsidiaries at any time without notice.

### **Offer of Sale**

The items described in this document are hereby offered for sale by Parker Hannifin Corporation, its subsidiaries or its authorized distributors. This offer and its acceptance are governed by provisions stated on a separate page of the document entitled 'Offer of Sale'.

# Table of Contents

## Newest Design Features of the H Series Cylinder

pages II-IV

### Overview – H Series

pages 1-6

Mounting Styles & Tips for Applying Them . . . . . 1	Model Code / How To Order . . . . . 4-5
Features and Benefits . . . . . 2-3	Piston Seal Options . . . . . 6

**A**  
Overview

### H Series 1.50" - 8.00" Bore

pages 7-41

H 1.50" - 8.00" Bore Specifications / Mounting Styles . . . . . 7	H 7.00" & 8.00" Bore Rod End Styles and Dimensions . . . . . 27
H 1.50" - 6.00" Bore Rod End Styles and Dimensions . . . . . 8-9	H 7.00" & 8.00" Bore Mount Dimensions . . . . . 28-40
H 1.50" - 6.00" Bore Mounting Information . . . . . 10-25	H 7.00" & 8.00" Bore Double Rod Models . . . . . 41
H 1.50" - 6.00" Bore Double Rod Cylinders . . . . . 26	

**B**  
H Series  
1.50" - 8.00" Bore

### H Series 10.00" - 20.00" Bore

pages 42-60

H 10.00" - 20.00" Bore Performance . . . . . 42	H 10.00" - 20.00" Bore Specifications / Mountings . . . . . 48
H 10.00" - 20.00" Bore Construction . . . . . 43	H 10.00" - 20.00" Bore Rod End Styles and Dimensions . . . . . 49
Model Code / How To Order . . . . . 44-45	H 10.00" - 20.00" Bore Mount Dimensions . . . . . 50-59
H 10.00" - 20.00" Bore Piston Seal Options . . . . . 46	H 10.00" - 20.00" Bore Double Rod Models . . . . . 60
H Series Large Bore Composite Bushing . . . . . 47	

**C**  
H Series  
10.00" - 20.00" Bore

### Engineering Data

pages 61-92

Metallic Rod Scraper, Crown Wiper, Rod End Boots, Bushings Drain and Air Bleeds . . . . . 62	Fluids and Temperature Range / Pressure Ratings . . . . . 69
Tie Rod Supports, Stroke Adjusters, Thrust Key Mountings, and Metric Piston Rod Thread . . . . . 63	Piston & Bushing Friction / Piston Orifice . . . . . 70-71
Theoretical Push & Pull Forces . . . . . 64-65	Ports, Stroke Data, Mounting Groups and Stop Tubing . . . . . 72-75
Global Shield™ Rod Coating . . . . . 66	Piston Rod Selection Data . . . . . 76-78
Cylinder Weights . . . . . 67	Cushioning . . . . . 79-84
Operating Fluids and Seals / Temperature Range . . . . . 68	Support Literature . . . . . 86-87
	Cylinder Safety Guide . . . . . 90-91
	Offer of Sale . . . . . 92

**D**  
Engineering  
Data

## ***Piston Sealing Solutions for the Most Demanding Applications***

### ***Piston Seal Technology For The 21st Century***

The new Atlas universal piston seal design addresses the performance balance between low pressure sealability, low friction, extrusion resistance and seal life.

One piston style is used for all piston seal and wear ring configurations and will suit all application requirements. A common piston design permits field changing of seal configuration or seal and wear band material without replacing costly machined components when variations in application parameters occur, such as fluid, temperature or duty cycle.

All piston options include dual non-metallic wear rings to provide maximum stability and bearing area for protection against eccentric loads.

WearGard™ wear rings are internally lubricated for reduced friction and formulated for heavy-duty load-bearing applications.

The standard piston style for Class 1 and 4 service is HP; for 2, 3, 5, 6 and 8 service the standard is KP. If a different piston style is desired for an eligible seal class, enter an 'S' in the Special Modification field of the model number and specify the piston style in text.

### ***Atlas HP Polyurethane Piston Seal***

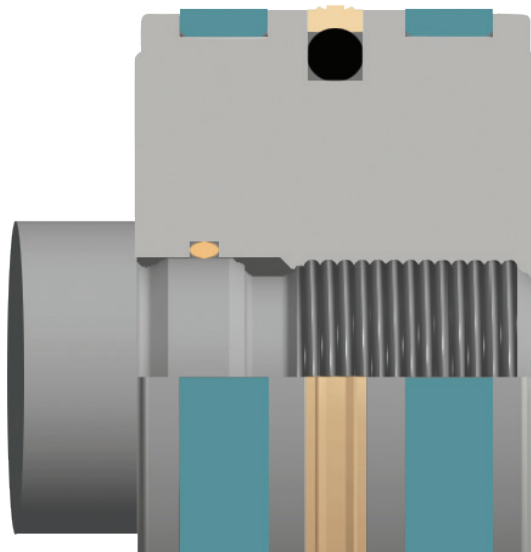

The Atlas HP energized bi-directional piston seal improves upon the low friction and long wear of lipseals by including excellent low pressure sealing performance. Specially formulated polyurethane is long wearing and abrasion resistant with running friction comparable to lipseals. An o-ring energizer ensures virtually zero leakage in low pressure applications. Also, pressure trapping that can result with energized lipseals is not possible with a single energized seal.

The Atlas HP piston seal is an excellent choice for most industrial applications operating with mineral based hydraulic oil and is available in Seal Classes 1 and 4.

### ***Atlas KP Filled PTFE Piston Seal***

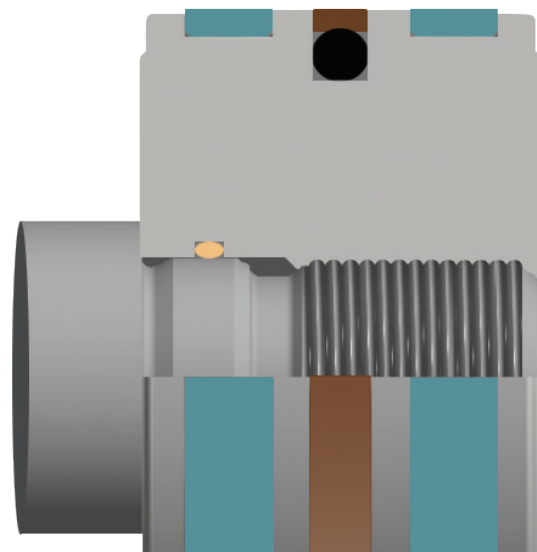

The Atlas KP bronze filled PTFE seal ring material has low running friction for accurate positioning in closed loop servo applications.

When combined with a fluorocarbon energizing ring the Atlas KP seal is rated for 400° F and will increase service intervals in high temperature applications even when compared to fluorocarbon lipseals.

By combining the Atlas KP seal with other energizer o-ring compounds and wear ring materials, the KP seal offers excellent service in all Seal Class environments.



**Selection Guide**

Application Demand	HP Seal	KP Seal	RP Seal	WP Seal
Load Holding	Best	Good	Good	Best
Fluid Compatibility	Good	Best	Better	Better
Heat Resistance	Good (200° F Max.)	Best (400° F Max.)	Better (300° F Max.)	Better (250° F Max.)
Dynamic Friction	Best	Best	Good	Better
Breakaway Friction	Good	Best	Good	Better
Extrusion Resistance	Good	Better	Best	Good
Fluid Isolation	N/A	N/A	N/A	Best

**Atlas RP Thermoplastic Seal**

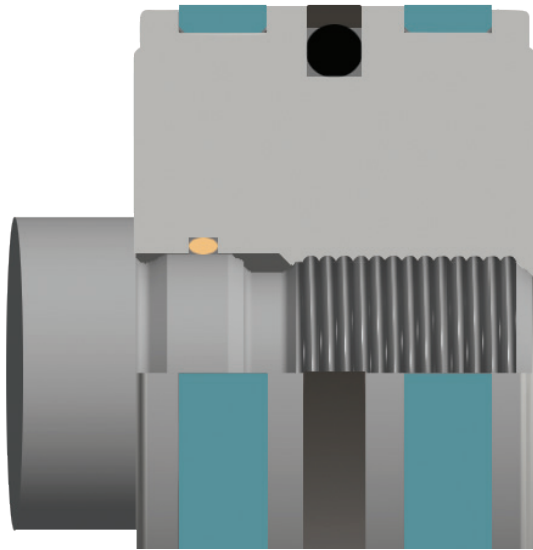

The Atlas RP step cut ring is made of self-lubricating, glass reinforced, thermoplastic and is o-ring energized. Unlike cast iron rings that bypass oil, the Atlas RP seal provides drift free operation throughout the operating pressure range. This tough seal is fully extrusion resistant, even in the face of extreme pressure spikes, thus ensuring superior wear resistance in the most demanding applications.

Atlas RP can operate up to 300° F and is compatible with Seal Classes 1, 2, 3, 4, 5 and 6.

**Atlas WP Mixed Media Seal**

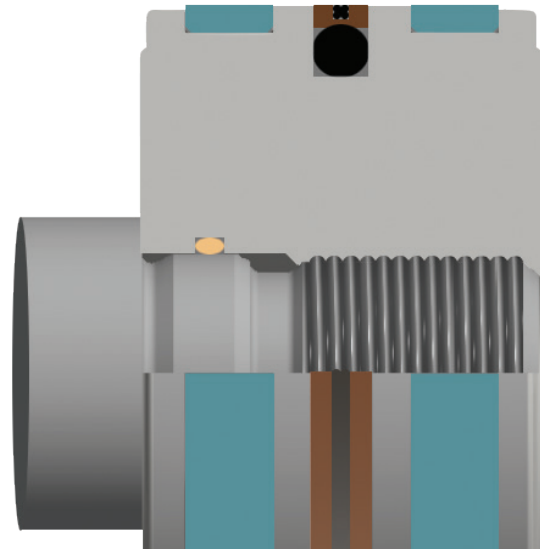

The Atlas WP Mixed Media seal is designed for applications requiring different media on either side of the piston. This option is ideal when hydraulic oil is on one side of the piston and air is on the opposite side; and it can be equally effective when dissimilar fluids are on either side of the piston.

Superior low-friction bi-directional sealing is accomplished by combining an energized filled PTFE seal with a redundant elastomer seal. Energizer and redundant elastomer seal materials are available for compatibility with seal classes 1, 2, 3, 5 and 6. Note: WP piston seal groove is not universal in 1.50" bore.

## **Versatile Piston Rod Sealing Systems Deliver Dry Rod Performance**

Atlas offers the best performing and broadest selection of rod sealing options. Our Tri-lip bolted bushing sealing system is a proven anchor of the offering.

As the rod strokes out, its motion and friction dynamically flex the multi-sealing edges of the Tri-Lip rod seal to maintain their contact with the rod. This provides a cutting action to shear the oil from the rod, allowing the rod to pass out of the rod seal practically dry. Any oil film that remains on the rod is stopped by the inner lip of the Wiperseal and held between it and the rod seal.

On the return stroke any dirt or foreign matter collected on the

rod is wiped off by the leading edge, or outer lip of the Wiperseal. At the same time, any oil which may be trapped between the Wiperseal and the rod seal is returned into the cylinder. In other words, we have an automatic check valve that prevents any appreciable amount of oil to leak past the seals, and then returns any oil that has managed to wipe by the rod seal.

Tri-Lip bushings are easily removed for service without loosening tie rods and disturbing the pressure envelope. Material options allow compatibility with Seal Classes 1, 2, 3, 4, 5 & 6.

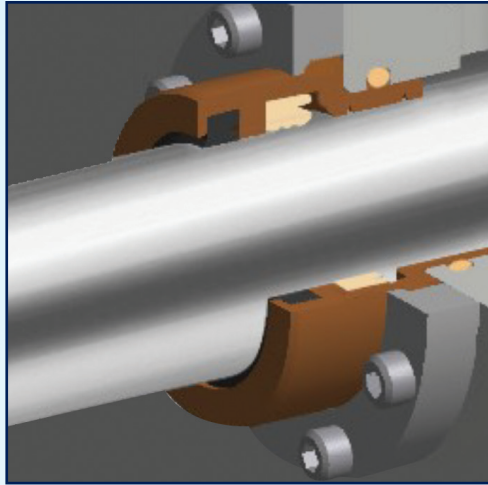

### **Buffer Seal Bushing**

The Atlas Buffer Seal, installed ahead of the primary rod seal, protects the primary seal from the effects of pressure spikes. The result is increased primary rod seal and wiperseal performance life when in severe applications.

The Atlas Buffer Seal is a unique design that allows trapped pressure back into the cylinder. When the rod extends

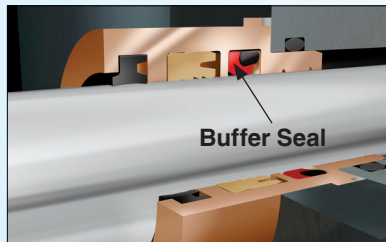

from the cylinder the Buffer Seal is riding on a high compression sealing point to limit leakage. On the retract stroke the seal rocks forward to allow trapped fluid to pass under the seal and return to the system.

Buffer Seals are available with Seal Classes 1, 2, 4 & 5. To order, enter an 'S' in the Special Modification field of the model number and specify Buffer Seal.

To accommodate the Buffer Seal, rod bushing length is extended 0.31" to 0.81", depending on rod diameter. See Buffer Seal Bushing page 61 for piston rod extension details.

### **Low Friction Bushing**

The Atlas Low Friction Bushing is designed to minimize 'slip-stick' and 'chatter' in servo and 'dither' applications. Two unidirectional bronze filled PTFE primary rod seals and a bronze filled PTFE wiperseal minimize both breakaway and running friction.

Low Friction Rod Seals are available for rod diameters 1.000" - 5.500" in 1.50" - 8.00" bores.

See Piston & Bushing Friction page for comparative seal friction data.

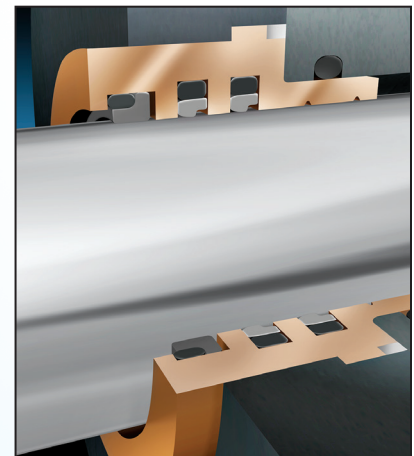

To order, enter an 'S' in the Special Modification field of the model number and specify Low Friction Bushing. Available with Seal Classes 1, 2, 3, 4, 5, 6 & 8.

## Mounting Styles & Tips for Applying Them

### Extended Tie Rod Mountings – TB, TC, and TD

**Application:**

- Straight line force transfer
- Compression loads (push)  
– use TC or TD
- Tension loads (pull)  
– use TB or TD

**Advantages:**

- Ease of mounting in tight spaces
- Force is transferred along the centerline of the cylinder

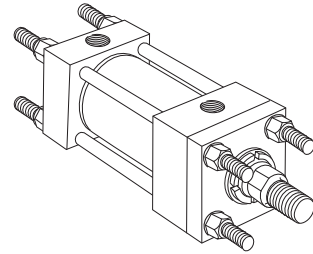

### Flange Mountings – J, JB, JJ, H, HB, and HH

**Application:**

- Straight line force transfer
- Compression loads (push)  
– use H, HB or HH
- Tension loads (pull)  
– use J, JB, or JJ

**Advantages:**

- Rigid base mounting due to large flange area
- Force is transferred along the centerline of the cylinder

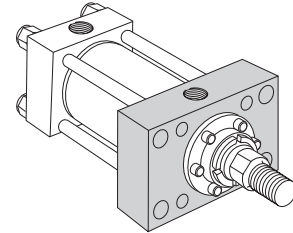

### Side Tap Mounting – F / Side Lug Mounting – C

**Application:**

- Straight line force transfer
- Can be used in compression or tension loads
- Thrust key and secure mounting area are vital

**Advantages:**

- Ease of mounting

**Recommendation:**

- Styles F & C should have a minimum stroke at least equal to the bore diameter

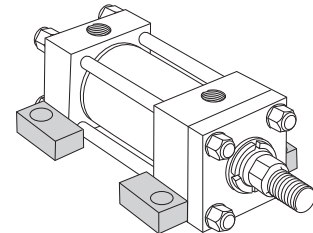

### Pivot Mountings – BB, SB and SE

**Application:**

- Curved or arc line force transfer
- Can be used in compression or tension loads
- Movement in a simple arc  
– use BB mountings
- Movement in a compound arc  
– use SB or SE mountings

**Advantages:**

- Ease of mounting
- Design flexibility
- Self aligning (SB or SE)

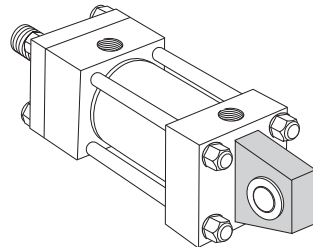

### Trunnion Mountings – D, DB, DD and DE

**Application:**

- Curved or arc line force transfer
- Can be used in compression or tension loads
- Compression loads – use DB or DD, DE mountings
- Tension loads – use D, DD or DE mountings

**Advantages:**

- Ease of mounting
- Design flexibility
- Self aligning

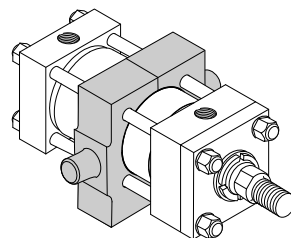

# The inside story on why H Series is your best choice in heavy duty hydraulic cylinders

Overview  
**A**

**Primary Seal** – Tri-lip Rod Seal is a proven leakproof design – completely self-compensating and self-relieving to withstand variations and conform to mechanical deflection that may occur.

**Secondary Seal** – Double-Service urethane Wiperseal™ wipes clean any oil film adhering to the rod on the extend stroke and cleans the rod on the return stroke.

**Rod Bushing Assembly** – Externally removable without cylinder disassembly. Long bearing surface is inboard of the seals, assuring positive lubrication from within the cylinder. An o-ring is used as a seal between bushing and head.

**Piston Rod Thread** – Male rod end styles #4A and #8A are integral cut threads on the piston rod. Optional studded KK small male thread, for piston rod diameters 2.000" and smaller, is available by specifying rod end style #4H.

**Piston Rod** – Medium carbon steel, induction case-hardened, hard chrome-plated and polished to 10 RMS finish. Piston rods are made from 85,000 to 100,000 psi minimum yield material in .625" through 4.000" diameters. Larger diameters vary between 57,000 and 90,000 psi minimum material, depending on rod diameter.

**Ports** – SAE "O" ring ports are standard.

**Optional Ports** – NPTF ports are optional at no extra charge. Oversize NPTF and SAE ports are available at extra charge.

**Hardened Steel Washers** – Insure accurate Tie Rod Prestress

**Align-A-Groove** – A 3/16" wide surface machined at each end of the cylinder body. Makes precise mounting quick and easy.

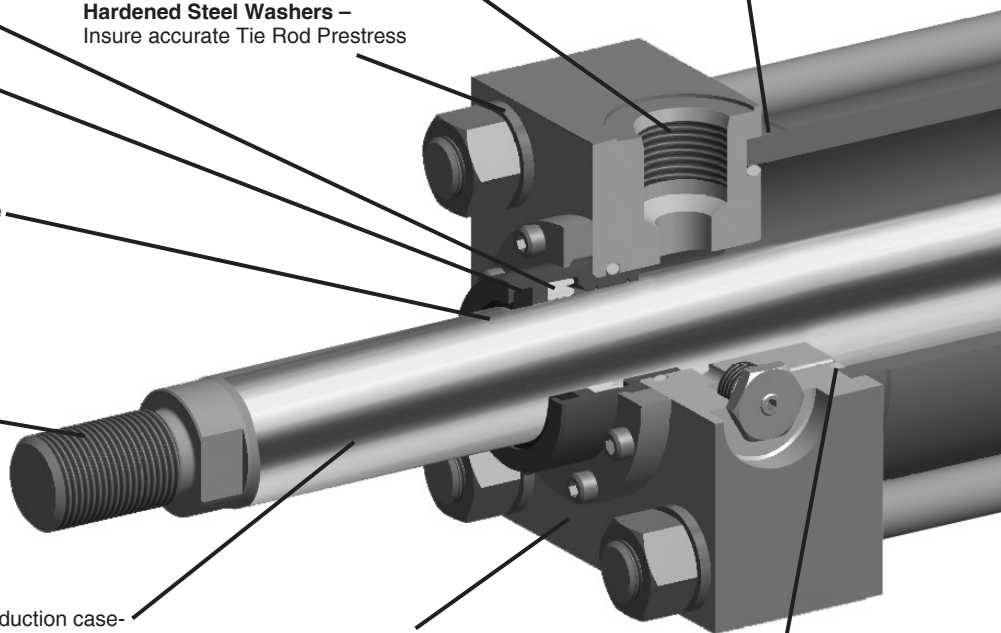

**Steel Head** – Precision finished on all sides; bored and grooved to provide concentricity for mating parts.

**End Seals** – Pressure-actuated cylinder body-to-head and cap o-rings.

## Atlas's stepped floating cushions combine the best features of known cushion technology.

Deceleration devices or built-in "cushions" are optional and can be supplied at head end, cap end, or both ends without change in envelope or mounting dimensions. Atlas cylinder cushions are a stepped design and combine the best features of known cushion technology.

Standard straight or tapered cushions have been used in industrial cylinders over a very broad range of applications. Atlas research has found that both designs have their limitations.

As a result, Atlas has taken a new approach in cushioning of industrial hydraulic cylinders and for specific load and velocity conditions have been able to obtain deceleration curves that come very close to the ideal. The success lies in a stepped sleeve or spear concept where the steps are calculated to approximate theoretical orifice area curves.

In the cushion performance chart, pressure traces show the results of typical orifice flow conditions. Tests of a three-step sleeve or spear show three pressure pulses coinciding with the steps. The deceleration cushion plunger curves shape comes

very close to being theoretical, with the exception of the last 1/2 inch of travel. This is a constant shape in order to have some flexibility in application. The stepped cushion design shows reduced pressure peaks for most load and speed conditions, with comparable reduction of objectionable stopping forces being transmitted to the load and the support structure.

All Atlas H cushions are adjustable.

The H Series cylinder design incorporates the longest cushion sleeve and cushion spear that can be provided in the standard envelope without decreasing the rod bearing and piston bearing strengths.

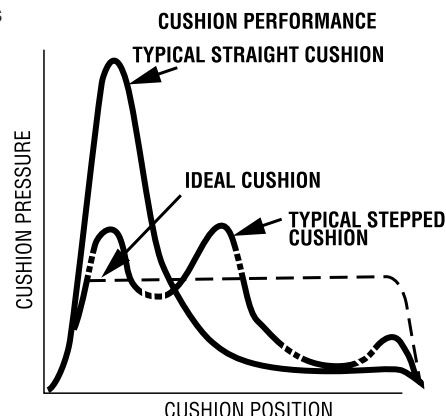



**Adjustable Floating Stepped Cushions** – For maximum performance – economical and flexible for even the most demanding applications – provides superior performance in reducing shock. Cushions are optional and can be supplied at head end, cap end, or both ends without change in envelope or mounting dimensions.

**Steel Cap** – Precision finished on all sides; bored and grooved to provide concentricity for mating parts.

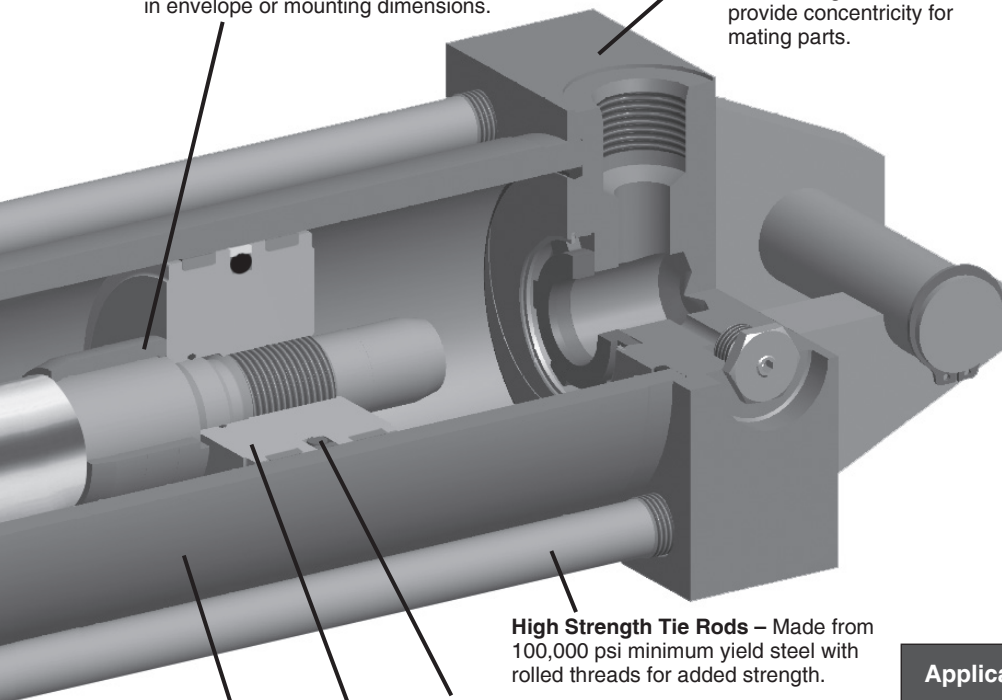

**Cylinder Body** – Heavy-wall steel tubing, honed to a micro finish bore.

**High Strength Tie Rods** – Made from 100,000 psi minimum yield steel with rolled threads for added strength.

**Problem Solving Piston Seal Options** – Atlas's new piston seal designs address the performance balance between low pressure seal ability, low friction, extrusion resistance and seal life.

**One-Piece Nodular Iron Piston** – Two non-metallic wear bands that minimize tube scoring are standard with all seal styles. Piston to rod connection is pre-stressed to maximize fatigue life. An o-ring on the piston ID ensures a leak free joint and anaerobic adhesive further secures the threaded connection.

**One Common Piston for 4 Seal Styles**

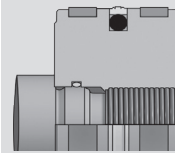

**Standard HP style** with polyurethane piston seal – excellent for most cycling and load holding applications.

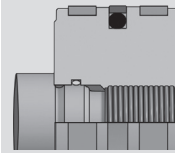

**Optional KP style** with filled PTFE piston seal – low friction, high heat resistance for cycling and load holding service.

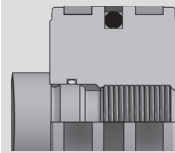

**Optional RP style** with thermoplastic piston seal – superior extrusion resistance to extreme pressure spikes with drift-free performance.

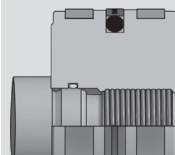

**Optional WP style** mixed media piston seal – low friction primary seal with redundant elastomer delivers superior performance with dissimilar media on either side of the piston.

Application Demand	HP Seal	KP Seal	RP Seal	WP Seal
<b>Load Holding</b>	Best	Good	Good	Best
<b>Fluid Compatibility</b>	Good	Best	Better	Better
<b>Heat Resistance</b>	Good	Best	Better	Better
<b>Dynamic Friction</b>	Best	Best	Good	Better
<b>Breakaway Friction</b>	Good	Best	Good	Better
<b>Extrusion Resistance</b>	Good	Better	Best	Good
<b>Fluid Isolation</b>	N/A	N/A	N/A	Best

(1) When a cushion is specified at the head end:

- a. A self-centering stepped sleeve is furnished on the piston rod assembly.
- b. A cartridge style needle valve is provided that is flush with the side of the head even when wide open. It is located on side number 2, in all mounting style models except ME5, ME6, TM1, TM2, TM3 and TM4. In these styles it is located on side number 3.
- c. All cylinder bores utilize a slotted sleeve as a check valve.

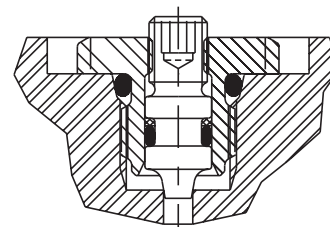

**Cartridge Style Needle Valve**

(2) When a cushion is specified at the cap end:

- a. A stepped cushion spear is provided on the piston rod.
- b. A "float check" self-centering bushing is provided in 1.50" - 6.00" bore cylinders, which incorporates a large flow check valve for fast "out-stroke" action. 7.00" bore and larger cylinders utilize a springless check valve located and identified in the same manner as the head end.
- c. A cartridge style needle valve is provided that is flush with the side of the cap when wide open. It is located on side number 2 in all models except ME5, ME6, TM1, TM2, TM3 and TM4. In these styles it is located on side number 3.

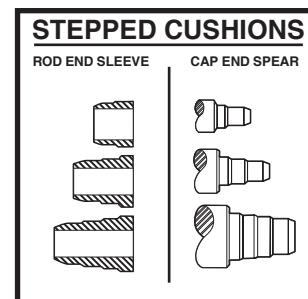

H Model Code

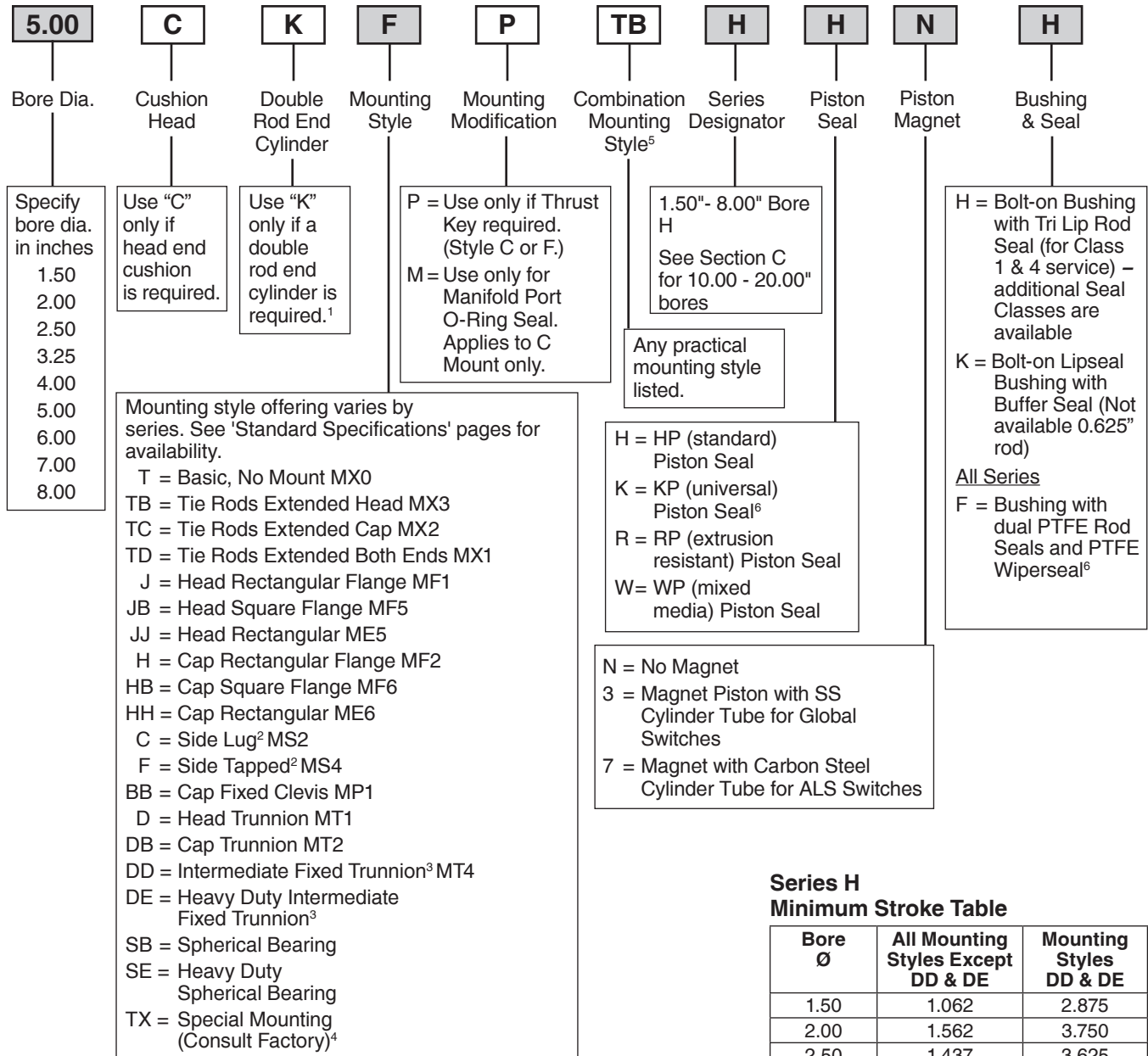

Series H Minimum Stroke Table

Bore Ø	All Mounting Styles Except DD & DE	Mounting Styles DD & DE
1.50	1.062	2.875
2.00	1.562	3.750
2.50	1.437	3.625
3.25	1.687	4.375
4.00	1.937	5.000
5.00	1.937	5.437
6.00	2.562	6.687
7.00	3.437	8.062
8.00	2.937	8.250

Shaded boxes identify required model number fields.

<sup>1</sup> Available mounting styles for K Type cylinders are located at the end of Section A. When ordering a double rod end cylinder, the piston rod number and piston rod end threads are to be specified for both rod ends.

The model number should be created as viewing the primary rod end on the left hand side.  
Example: K Type Cylinder:  
4.00CKTDHT14A28AC10.000

<sup>2</sup> Mounting Styles C and F should have a minimum stroke length equal to or greater than their bore size.

<sup>3</sup> Specify XI dimension.

<sup>4</sup> Special mounting styles that do not resemble a standard catalog offering will be designated as style TX by the factory.

<sup>5</sup> In general, the model numbers as read left to right corresponding to the cylinder as viewed from left to right with the primary end at the left. The second or subsequent mountings are mountings called out as they appear in the assembly moving away from the rod end. Except when tie rod extension mountings are part of a combination, all combinations should have a "S" (Special) in the model code and a note in the body of the order clarifying the mounting arrangement. The "P", as used to define a thrust key is not considered to be a mounting. However it is located at the primary end.

<sup>6</sup> Piston seal code K and Bushing & Seal code F must be selected for Class 8 service. Dual PTFE rod seals with PTFE wiperseal not available for 0.625" rod.

**H Model Code**

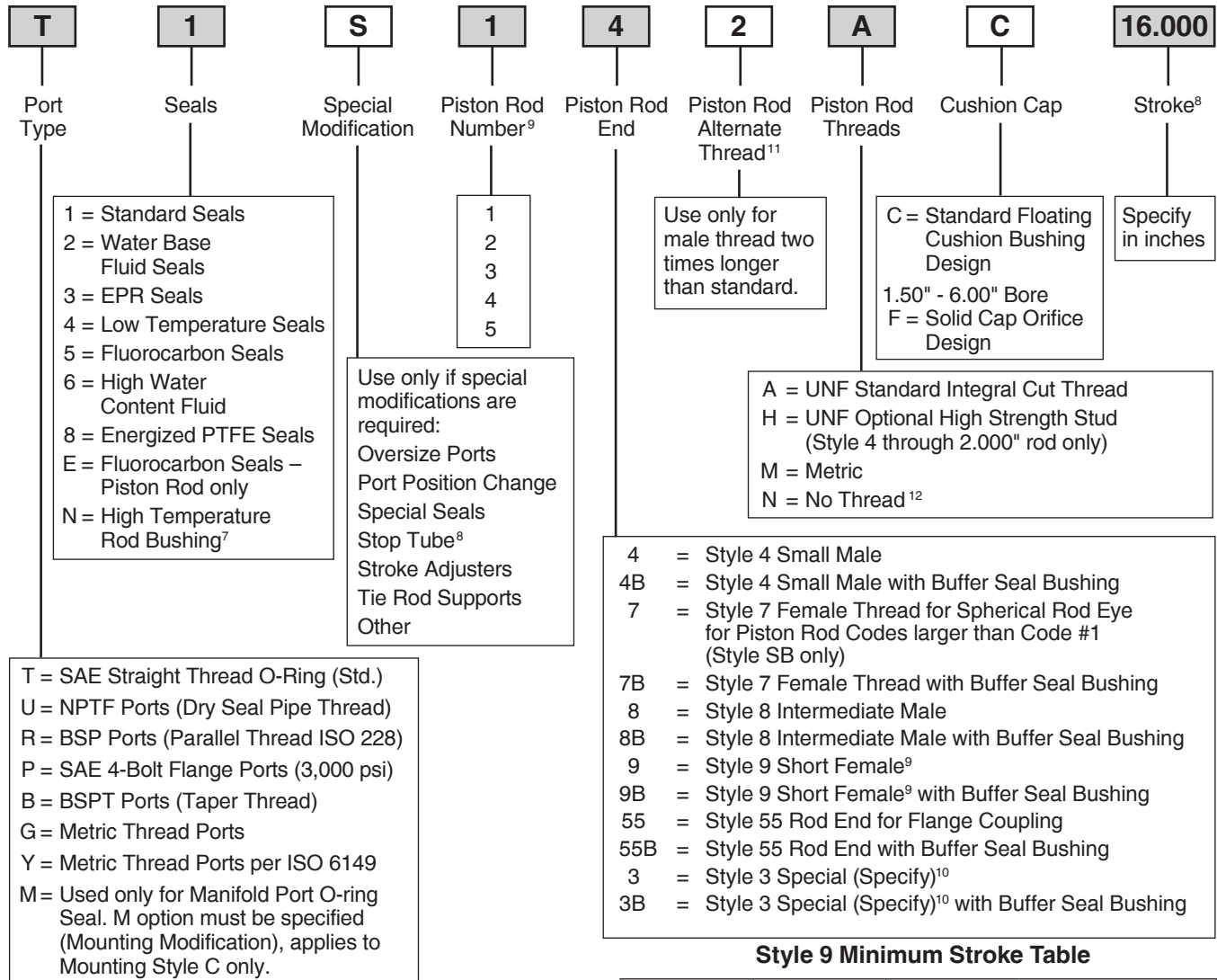

**Style 9 Minimum Stroke Table**

Bore Ø	Rod Ø	Minimum Stroke	
		Style 9	Style 9B
1.50 - 4.00	All	None	None
5.00	2.000	None	None
	2.500	1.000	0.56
	3.000	1.375	0.94
	3.500	1.625	1.19
6.00	2.500	None	None
	3.000	1.375	0.94
	3.500	1.375	0.94
	4.000	2.000	1.56
7.00	3.000	1.250	0.81
	3.500	1.500	1.06
	4.000	1.500	1.06
	4.500	2.500	2.06
	5.000	3.125	2.31
8.00	3.500	1.500	1.06
	4.000	1.500	1.06
	4.500	2.375	1.94
	5.000	2.875	2.06
	5.500	3.625	2.81

Shaded boxes identify required model number fields.

<sup>7</sup> Energized PTFE rod seals & wiperseal. All other cylinder seals are fluorocarbon. Not available for 0.625" rod.

<sup>8</sup> S = Stop Tube. Specify: stop tube length, net stroke and gross stroke. Gross stroke = stop tube length + net stroke. Gross stroke to be placed in the model number field.

Example:  
 2.000 inches long stop tube  
 ±14.000 inches net stroke  
 16.000 inches gross stroke

See tables on these pages for minimum allowable strokes for Series H and Piston Rod End Styles 9 & 9B.

<sup>9</sup> Style 9 stroke restrictions may apply. See Style 9 Minimum Stroke Table for details.

<sup>10</sup> Provide dimensions for KK, A, W or WF. If otherwise special, furnish dimensioned sketch.

<sup>11</sup> Available only in combination with Style 4 or Style 8.

<sup>12</sup> Must be specified for Piston Rod End Style 55.



**Piston Seal Selection**

Atlas Piston Seal options HP, KP, RP and WP are available in a number of different Seal Classes. Because the Atlas Model Number includes Seal Class but does not include a code for piston seal style, a default piston seal style is designated for each seal class. In the table below rows list each seal class and columns column list each piston style. Available piston styles

for each seal class are identified with an 'X' and the default piston seal style is in the shaded cell. To specify an available piston seal style that is not standard, place an 'S' in the Special Modification field of the model number and specify the required piston seal style with text.

Seal Class	Piston Seal Options (Shaded cell is default standard)			
	HP	KP	RP	WP
Class 1 - Polyurethane & Nitrile	X	X	X	X
Class 2 - Nitrile	N/A	X	X	X
Class 3 - EPR	N/A	X	X	X
Class 4 - Low Temperature Nitrile	X	X	X	N/A
Class 5 - Fluorocarbon	N/A	X	X	X
Class 5 Rod Bushing Seals Only	N/A	X	X	X
Class 6 - Nitroxile	N/A	X	X	X
Class 8 - Filled PTFE High Temperature	N/A	X	N/A	N/A
Class 8 Rod Bushing Seals Only (all others Fluorocarbon)	N/A	N/A	X	X

**One Common Piston for 4 Seal Styles**

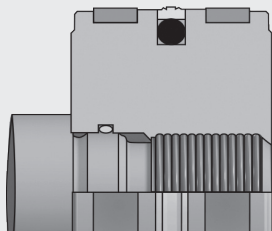

**Standard HP** style with polyurethane piston seal – excellent for most cycling and load holding applications.

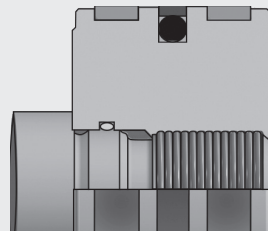

**Optional RP** style with thermoplastic piston seal – superior extrusion resistance to extreme pressure spikes with drift-free performance.

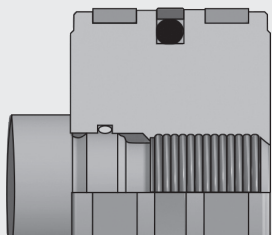

**Optional KP** style with filled PTFE piston seal – low friction, high heat resistance for cycling and load holding service.

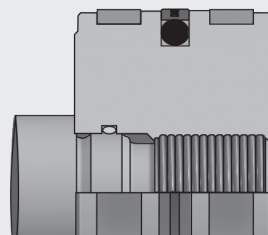

**Optional WP** style mixed media piston seal – low friction primary seal with redundant elastomer delivers superior performance with dissimilar media on either side of the piston.

**Standard Specifications**

- Heavy Duty Service – ANSI/(NFPA) T3.6.7R3 - 2009 Specifications and Mounting Dimension Standards
- Standard Construction – Square Head – Tie Rod Design
- Nominal Pressure – 3000 psi<sup>1</sup>
- Standard Fluid – Hydraulic Oil
- Standard Temperature – -10°F to +165°F<sup>2</sup>
- Bore Diameters – 1.50" through 8.00" (Larger sizes available)

- Piston Rod Diameter – 0.625" through 5.500"
- Mounting Styles – 19 standard styles at various application ratings
- Strokes – Available in any practical stroke length
- Cushions – Optional at either end or both ends of stroke. "Float Check" standard at cap end of 1.50" - 6.00" bore.
- Rod Ends – Four Standard Choices – Specials to Order

*In line with our policy of continuing product improvement, specifications in this catalog are subject to change.*

Note: H Series Hydraulic Cylinders fully meet ANSI/(NFPA) T3.6.7R3 - 2009 Specifications and Mounting Dimension Standards for Square Head Industrial Fluid Power Cylinders.

<sup>1</sup> If hydraulic operating pressure exceeds 3000 psi, send application data for engineering evaluation and recommendation. See Section D for actual design factors.

<sup>2</sup> See Section D for higher temperature service.

**Available Mounting Styles**

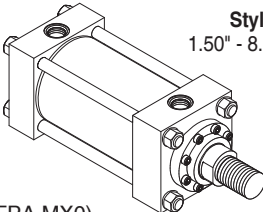
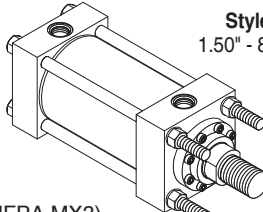
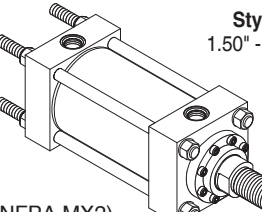
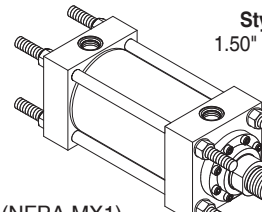
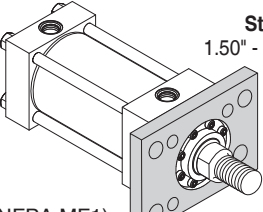
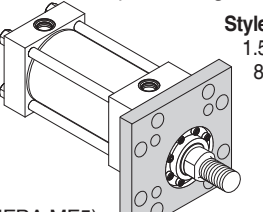
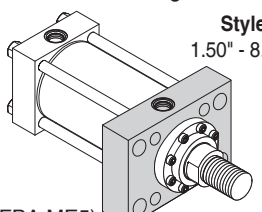
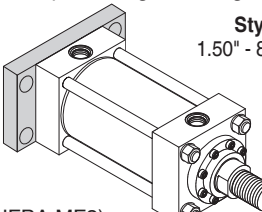
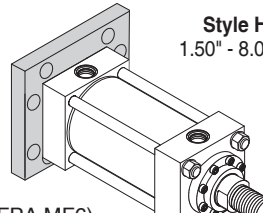
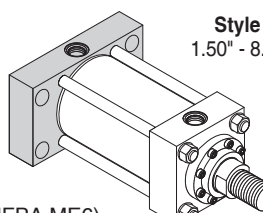
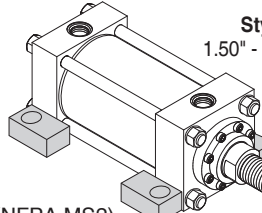
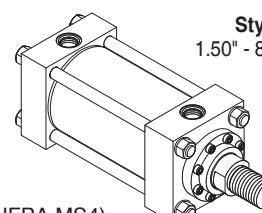
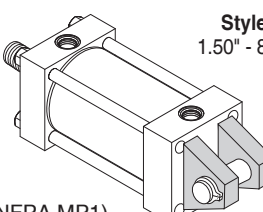
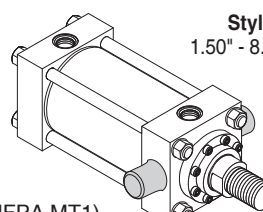
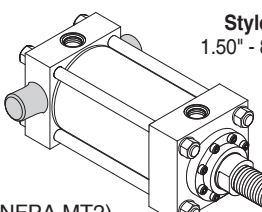
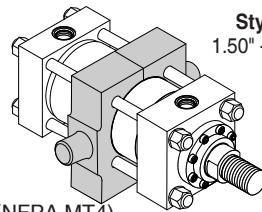
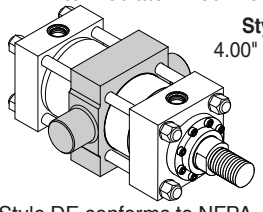
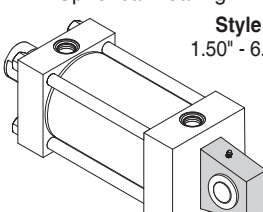
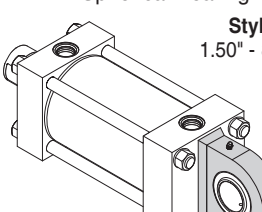
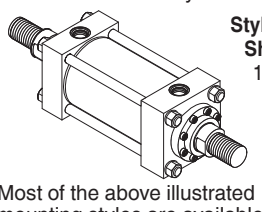
<p>Basic <b>Style T</b> 1.50" - 8.00"</p>  <p>(NFPA MX0)</p>	<p>Tie Rods Extended Head End <b>Style TB</b> 1.50" - 8.00"</p>  <p>(NFPA MX3)</p>	<p>Tie Rods Extended Cap End <b>Style TC</b> 1.50" - 8.00"</p>  <p>(NFPA MX2)</p>	<p>Tie Rods Extended Both Ends <b>Style TD</b> 1.50" - 8.00"</p>  <p>(NFPA MX1)</p>
<p>Head Rectangular Flange <b>Style J</b> 1.50" - 8.00"</p>  <p>(NFPA MF1)</p>	<p>Head Square Flange <b>Style JB</b> 1.50" - 8.00"</p>  <p>(NFPA MF5)</p>	<p>Head Rectangular <b>Style JJ</b> 1.50" - 8.00"</p>  <p>(NFPA ME5)</p>	<p>Cap Rectangular Flange <b>Style H</b> 1.50" - 8.00"</p>  <p>(NFPA MF2)</p>
<p>Cap Square Flange <b>Style HB</b> 1.50" - 8.00"</p>  <p>(NFPA MF6)</p>	<p>Cap Rectangular <b>Style HH</b> 1.50" - 8.00"</p>  <p>(NFPA ME6)</p>	<p>Side Lug <b>Style C</b> 1.50" - 8.00"</p>  <p>(NFPA MS2)</p>	<p>Side Tapped <b>Style F</b> 1.50" - 8.00"</p>  <p>(NFPA MS4)</p>
<p>Cap Fixed Clevis <b>Style BB</b> 1.50" - 8.00"</p>  <p>(NFPA MP1)</p>	<p>Head Trunnion <b>Style D</b> 1.50" - 8.00"</p>  <p>(NFPA MT1)</p>	<p>Cap Trunnion <b>Style DB</b> 1.50" - 8.00"</p>  <p>(NFPA MT2)</p>	<p>Intermediate Fixed Trunnion <b>Style DD</b> 1.50" - 8.00"</p>  <p>(NFPA MT4)</p>
<p>HD Intermediate Fixed Trunnion <b>Style DE</b> 4.00" - 8.00"</p>  <p>Style DE conforms to NFPA dimensional standard.</p>	<p>Spherical Bearing <b>Style SB</b> 1.50" - 6.00"</p> 	<p>HD Spherical Bearing <b>Style SE</b> 1.50" - 8.00"</p> 	<p>Double Rod Cylinders <b>Style KT Shown</b> 1.50" - 8.00"</p>  <p>Most of the above illustrated mounting styles are available in double rod cylinders.</p>

**B**  
H Series  
1.50" - 8.00" Bore

**Rod End Dimensions – circular bolt-on retainer construction**

**Thread Style 4 (NFPA Style SM)  
Small Male**

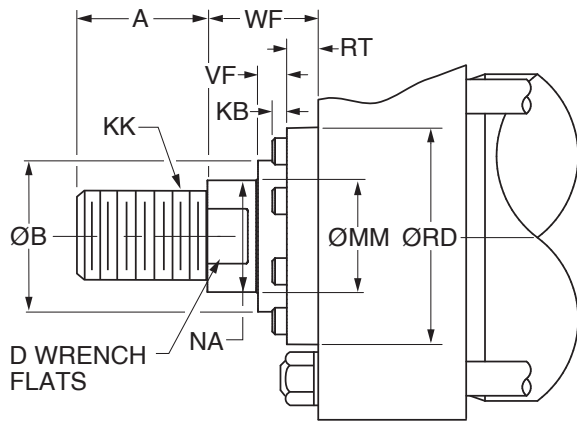

**Thread Style 8 (NFPA Style IM)  
Intermediate Male**

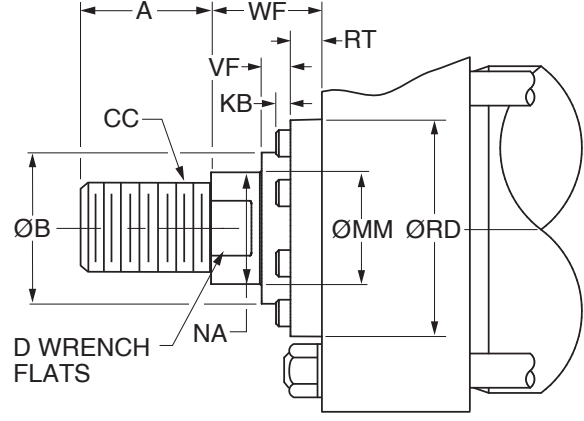

See Bushing Retention page to determine which bore, rod and mounting style combinations have circular bolt-on retainers and which have tie rod retained bushings.

**Rod End Dimensions**

Bore Ø	Rod No.	MM Rod Ø	Thread		A	B Ø +.000 -0.002	D	F	KB	NA	RD	RT	V	VF	W	WF
			Style 8 CC	Style 4 KK												
1.50	1 (Std.)	0.625	1/2-20	7/16-20	0.75	1.124	0.50	0.38	0.03	0.56	1.94	0.36	0.25	0.27	0.63	1.00
	2	1.000	7/8-14	3/4-16	1.13	1.499	0.88	0.38	0.03	0.94	2.38	0.36	0.50	0.52	1.00	1.38
2.00	1 (Std.)	1.000	7/8-14	3/4-16	1.13	1.499	0.88	0.63	0.03	0.94	2.38	0.36	0.25	0.52	0.75	1.38
	2	1.375	1 1/4-12	1-14	1.63	1.999	1.13	0.63	0.19	1.31	2.87	0.36	0.38	0.64	1.00	1.63
2.50	1 (Std.)	1.000	7/8-14	3/4-16	1.13	1.499	0.88	0.63	0.03	0.94	2.38	0.36	0.25	0.52	0.75	1.38
	2	1.750	1 1/2-12	1 1/4-12	2.00	2.374	1.50	0.63	0.03	1.69	3.47	0.60	0.50	0.53	1.25	1.88
	3	1.375	1 1/4-12	1-14	1.63	1.999	1.13	0.63	0.19	1.31	2.87	0.36	0.38	0.64	1.00	1.63
3.25	1 (Std.)	1.375	1 1/4-12	1-14	1.63	1.999	1.13	0.75	0.19	1.31	2.87	0.36	0.25	0.64	0.88	1.63
	2	2.000	1 3/4-12	1 1/2-12	2.25	2.624	1.69	0.75	0.13	1.94	3.72	0.60	0.38	0.53	1.25	2.00
	3	1.750	1 1/2-12	1 1/4-12	2.00	2.374	1.50	0.75	0.03	1.69	3.47	0.60	0.38	0.53	1.13	1.88
4.00	1 (Std.)	1.750	1 1/2-12	1 1/4-12	2.00	2.374	1.50	0.88	0.03	1.69	3.47	0.60	0.25	0.53	1.00	1.88
	2	2.500	2 1/4-12	1 7/8-12	3.00	3.124	2.06	0.88	0.25	2.38	4.25	0.60	0.38	0.65	1.38	2.25
	3	2.000	1 3/4-12	1 1/2-12	2.25	2.624	1.69	0.88	0.13	1.94	3.72	0.60	0.25	0.53	1.13	2.00
5.00	1 (Std.)	2.000	1 3/4-12	1 1/2-12	2.25	2.624	1.69	0.88	0.13	1.94	3.72	0.60	0.25	0.53	1.13	2.00
	2	3.500	3 1/4-12	2 1/2-12	3.50	4.249	3.00	0.88	-	3.38	5.76	0.91	0.38	0.34	1.38	2.25
	3	2.500	2 1/4-12	1 7/8-12	3.00	3.124	2.06	0.88	0.25	2.38	4.25	0.60	0.38	0.65	1.38	2.25
	4	3.000	2 3/4-12	2 1/4-12	3.50	3.749	2.63	0.88	-	2.88	5.26	0.85	0.38	0.41	1.38	2.25
6.00	1 (Std.)	2.500	2 1/4-12	1 7/8-12	3.00	3.124	2.06	1.00	0.25	2.38	4.25	0.60	0.25	0.65	1.25	2.25
	2	4.000	3 3/4-12	3-12	4.00	4.749	3.38	1.00	-	3.88	6.31	0.91	0.25	0.34	1.25	2.25
	3	3.000	2 3/4-12	2 1/4-12	3.50	3.749	2.63	1.00	-	2.88	5.26	0.85	0.25	0.41	1.25	2.25
	4	3.500	3 1/4-12	2 1/2-12	3.50	4.249	3.00	1.00	-	3.38	5.76	0.91	0.25	0.34	1.25	2.25

**“Special” Thread Style 3 (Previous Style X)**

Special thread, extension, rod eye, blank, etc., are also available.

To order, specify “Style 3” and give desired dimensions for KK, A, W or WF. If otherwise special, furnish dimensioned sketch.



**Rod End Dimensions – circular bolt-on retainer construction**

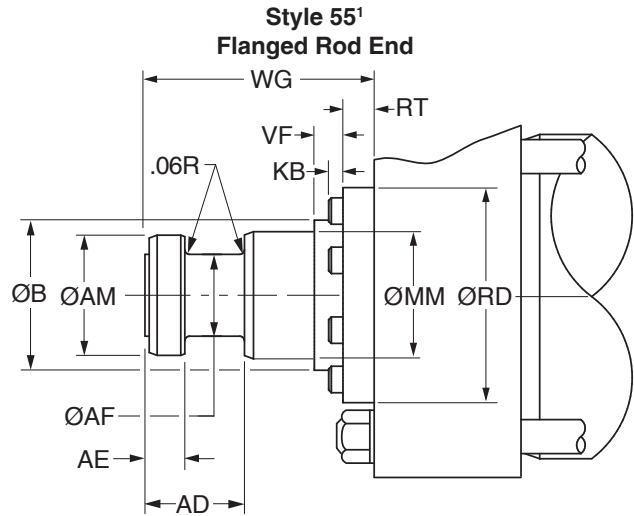
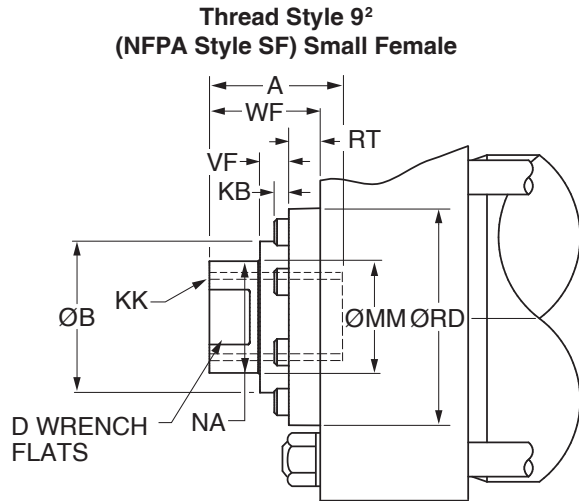

See Bushing Retention page to determine which bore, rod and mounting style combinations have circular bolt-on retainers and which have tie rod retained bushings.

**Rod End Dimensions**

Bore Ø	Rod No.	MM Rod Ø	Thread Style 9 KK	A	AD	AE +.001 -.001	AF Ø	AM Ø	B Ø +.000 -.002	D	KB	NA	RD	RT	VF	WF	WG
	2	1.000	3/4-16	1.13	0.94	0.374	0.69	0.95	1.499	0.88	0.03	0.94	2.38	0.36	0.52	1.38	2.38
2.00	1 (Std.)	1.000	3/4-16	1.13	0.94	0.374	0.69	0.95	1.499	0.88	0.03	0.94	2.38	0.36	0.52	1.38	2.38
	2	1.375	1-14	1.63	1.06	0.374	0.88	1.32	1.999	1.13	0.19	1.31	2.87	0.36	0.64	1.63	2.75
2.50	1 (Std.)	1.000	3/4-16	1.13	0.94	0.374	0.69	0.95	1.499	0.88	0.03	0.94	2.38	0.36	0.52	1.38	2.38
	2	1.750	1 1/4-12	2.00	1.31	0.499	1.13	1.70	2.374	1.50	0.03	1.69	3.47	0.60	0.53	1.88	3.13
	3	1.375	1-14	1.63	1.06	0.374	0.88	1.32	1.999	1.13	0.19	1.31	2.87	0.36	0.64	1.63	2.75
3.25	1 (Std.)	1.375	1-14	1.63	1.06	0.374	0.88	1.32	1.999	1.13	0.19	1.31	2.87	0.36	0.64	1.63	2.75
	2	2.000	1 1/2-12	2.25	1.69	0.624	1.38	1.95	2.624	1.69	0.13	1.94	3.72	0.60	0.53	2.00	3.75
	3	1.750	1 1/4-12	2.00	1.31	0.499	1.13	1.70	2.374	1.50	0.03	1.69	3.47	0.60	0.53	1.88	3.13
4.00	1 (Std.)	1.750	1 1/4-12	2.00	1.31	0.499	1.13	1.70	2.374	1.50	0.03	1.69	3.47	0.60	0.53	1.88	3.13
	2	2.500	1 7/8-12	3.00	1.94	0.749	1.75	2.45	3.124	2.06	0.25	2.38	4.25	0.60	0.65	2.25	4.50
	3	2.000	1 1/2-12	2.25	1.69	0.624	1.38	1.95	2.624	1.69	0.13	1.94	3.72	0.60	0.53	2.00	3.75
5.00	1 (Std.)	2.000	1 1/2-12	2.25	1.69	0.624	1.38	1.95	2.624	1.69	0.13	1.94	3.72	0.60	0.53	2.00	3.75
	2	3.500	2 1/2-12	3.50	2.69	0.999	2.50	3.45	4.249	3.00	-	3.38	5.76	0.91	0.34	2.25	5.63
	3	2.500	1 7/8-12	3.00	1.94	0.749	1.75	2.45	3.124	2.06	0.25	2.38	4.25	0.60	0.65	2.25	4.50
	4	3.000	2 1/4-12	3.50	2.44	0.874	2.25	2.95	3.749	2.63	-	2.88	5.26	0.85	0.41	2.25	4.88
6.00	1 (Std.)	2.500	1 7/8-12	3.00	1.94	0.749	1.75	2.45	3.124	2.06	0.25	2.38	4.25	0.60	0.65	2.25	4.50
	2	4.000	3-12	4.00	2.69	0.999	3.00	3.95	4.749	3.38	-	3.88	6.31	0.91	0.34	2.25	5.75
	3	3.000	2 1/4-12	3.50	2.44	0.874	2.25	2.95	3.749	2.63	-	2.88	5.26	0.85	0.41	2.25	4.88
	4	3.500	2 1/2-12	3.50	2.69	0.999	2.50	3.45	4.249	3.00	-	3.38	5.76	0.91	0.34	2.25	5.63

**“Special” Thread Style 3 (Previous Style X)**

Special thread, extension, rod eye, blank, etc., are also available.

To order, specify “Style 3” and give desired dimensions for KK, A, W or WF. If otherwise special, furnish dimensioned sketch.

<sup>1</sup> For special WG dimension, specify “Style 3” and give desired dimension for WG. For other changes, place “S” in the model code, and describe rod end with dimensioned sketch.

<sup>2</sup> Style 9 stroke restrictions may apply. See Style 9 Minimum Stroke Table on How to Order page for details.



**Tie Rods Extended Both Ends Mounting**  
**Style TD**  
 (NFFA Style MX1)

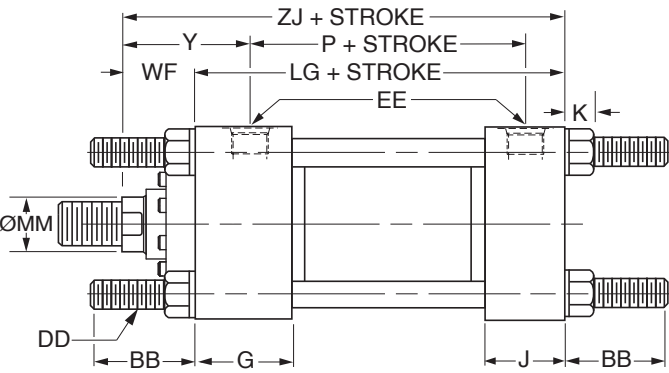
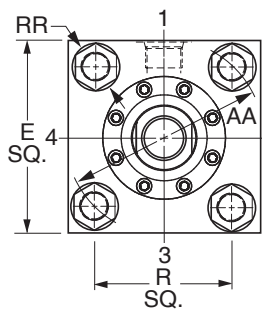
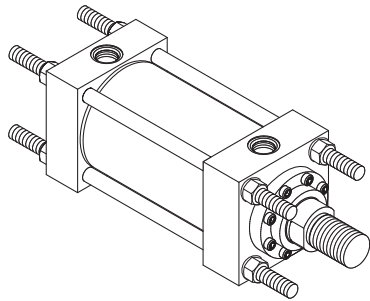

**Style TD – Dimensional and Mounting Data**

Bore Ø	Rod No.	MM Rod Ø	AA	BB	DD	E	EE		G	J	K Max.	R	RR	WF	Y	Add Stroke		
							NPTF <sup>1</sup>	SAE <sup>2</sup>								LG	P	ZJ
1.50	1 (std.)	0.625	2.31	1.38	3/8-24	2.50	1/2	10 <sup>†</sup>	1.75	1.50	0.42	1.63	0.68	1.00	2.00	4.63	2.88	5.63
	2	1.000	2.31	1.38	3/8-24	2.50	1/2	10 <sup>†</sup>	1.75	1.50	0.42	1.63	0.68	1.38	2.38	4.63	2.88	6.00
2.00	1 (std.)	1.000	2.90	1.81	1/2-20	3.00	1/2	10 <sup>†</sup>	1.75	1.50	0.57	2.05	0.90	1.38	2.38	4.63	2.88	6.00
	2	1.375	2.90	1.81	1/2-20	3.00	1/2	10 <sup>†</sup>	1.75	1.50	0.57	2.05	0.90	1.63	2.63	4.63	2.88	6.25
2.50	1 (std.)	1.000	3.61	1.81	1/2-20	3.50	1/2	10 <sup>†</sup>	1.75	1.50	0.57	2.55	0.90	1.38	2.38	4.75	3.00	6.13
	2	1.750	3.61	1.81	1/2-20	3.50	1/2	10 <sup>†</sup>	1.75	1.50	0.57	2.55	0.90	1.88	2.88	4.75	3.00	6.63
	3	1.375	3.61	1.81	1/2-20	3.50	1/2	10 <sup>†</sup>	1.75	1.50	0.57	2.55	0.90	1.63	2.63	4.75	3.00	6.38
3.25	1 (std.)	1.375	4.60	2.31	5/8-18	4.50	3/4	12	2.00	1.75	0.68	3.25	1.11	1.63	2.75	5.50	3.50	7.13
	2	2.000	4.60	2.31	5/8-18	4.50	3/4	12	2.00	1.75	0.68	3.25	1.11	2.00	3.13	5.50	3.50	7.50
	3	1.750	4.60	2.31	5/8-18	4.50	3/4	12	2.00	1.75	0.68	3.25	1.11	1.88	3.00	5.50	3.50	7.38
4.00	1 (std.)	1.750	5.40	2.31	5/8-18	5.00	3/4	12	2.00	1.75	0.68	3.82	1.11	1.88	3.00	5.75	3.75	7.63
	2	2.500	5.40	2.31	5/8-18	5.00	3/4	12	2.00	1.75	0.68	3.82	1.11	2.25	3.38	5.75	3.75	8.00
	3	2.000	5.40	2.31	5/8-18	5.00	3/4	12	2.00	1.75	0.68	3.82	1.11	2.00	3.13	5.75	3.75	7.75
5.00	1 (std.)	2.000	7.00	3.19	7/8-14	6.50	3/4	12	2.00	1.75	0.94	4.95	1.55	2.00	3.13	6.25	4.25	8.25
	2	3.500	7.00	3.19	7/8-14	6.50	3/4	12	2.00	1.75	0.94	4.95	1.55	2.25	3.38	6.25	4.25	8.50
	3	2.500	7.00	3.19	7/8-14	6.50	3/4	12	2.00	1.75	0.94	4.95	1.55	2.25	3.38	6.25	4.25	8.50
	4	3.000	7.00	3.19	7/8-14	6.50	3/4	12	2.00	1.75	0.94	4.95	1.55	2.25	3.38	6.25	4.25	8.50
6.00	1 (std.)	2.500	8.10	3.63	1-14	7.50	1	16	2.25	2.25	1.05	5.73	1.77	2.25	3.50	7.38	4.88	9.63
	2	4.000	8.10	3.63	1-14	7.50	1	16	2.25	2.25	1.05	5.73	1.77	2.25	3.50	7.38	4.88	9.63
	3	3.000	8.10	3.63	1-14	7.50	1	16	2.25	2.25	1.05	5.73	1.77	2.25	3.50	7.38	4.88	9.63
	4	3.500	8.10	3.63	1-14	7.50	1	16	2.25	2.25	1.05	5.73	1.77	2.25	3.50	7.38	4.88	9.63

<sup>1</sup>NPTF ports are available at no extra charge.

<sup>2</sup>SAE straight thread ports are standard and are indicated by port number.

<sup>†</sup>Previously number 8 SAE in 1.50 thru 2.50 bores now number 10 SAE.

**Style T**

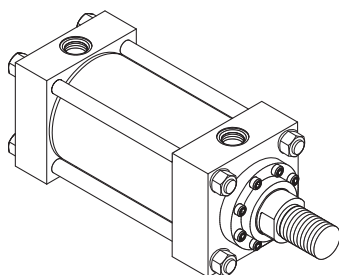

**Style TC**

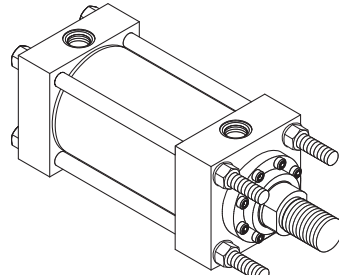

**Style TB**

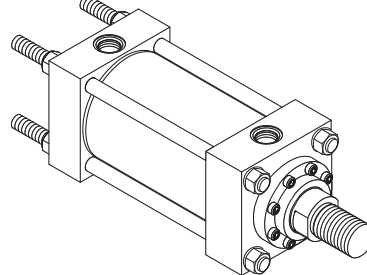

Dimensions for T, TB and TC Mount may be obtained from the above dimensional table.

1.50" - 6.00" Bore  
 H Series  
**B**

**Head Rectangular Flange Mounting**

Style J  
 (NFPA Style MF1)

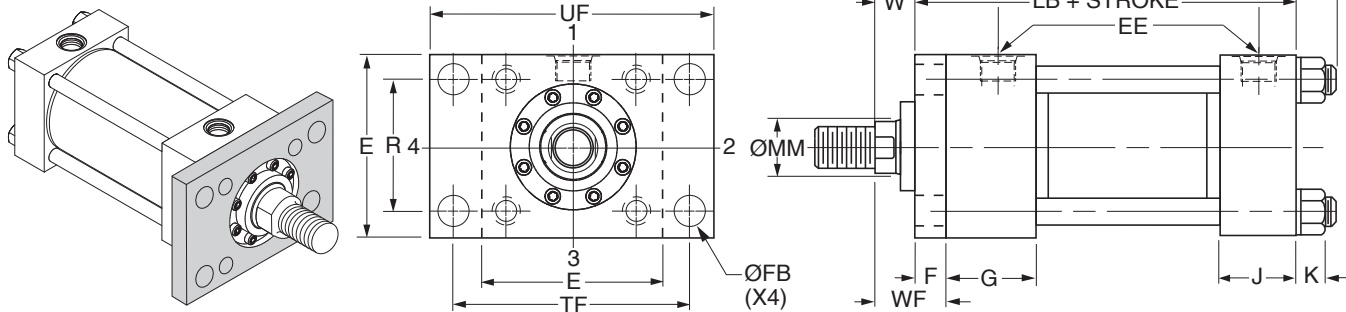

**Style J – Dimensional and Mounting Data**

Bore Ø	E	EE		F	FB Ø	G	J	K Max.	R	TF	UF	Add Stroke	
		NPTF <sup>1</sup>	SAE <sup>2</sup>									LB	P
1.50	2.50	1/2	10 <sup>3</sup>	0.38	0.44	1.75	1.50	0.42	1.63	3.44	4.25	5.00	2.88
2.00	3.00	1/2	10 <sup>3</sup>	0.63	0.56	1.75	1.50	0.57	2.05	4.13	5.13	5.25	2.88
2.50	3.50	1/2	10 <sup>3</sup>	0.63	0.56	1.75	1.50	0.57	2.55	4.63	5.63	5.38	3.00
3.25	4.50	3/4	12	0.75	0.69	2.00	1.75	0.68	3.25	5.88	7.13	6.25	3.50
4.00	5.00	3/4	12	0.88	0.69	2.00	1.75	0.68	3.82	6.38	7.63	6.63	3.75
5.00	6.50	3/4	12	0.88	0.94	2.00	1.75	0.94	4.95	8.19	9.75	7.13	4.25
6.00	7.50	1	16	1.00	1.06	2.25	2.25	1.05	5.73	9.44	11.25	8.38	4.88

<sup>1</sup>NPTF ports are available at no extra charge.

<sup>2</sup>SAE straight thread ports are standard and are indicated by port number.

<sup>3</sup>Previously number 8 SAE in 1.50 thru 2.50 bores now number 10 SAE.

**Style J – Dimensional and Mounting Data**

Bore Ø	Rod No.	MM Rod Ø	W	WF	Y	Add Stroke
						ZB Max.
1.50	1 (std.)	0.625	0.63	1.00	2.00	6.29
	2	1.000	1.00	1.38	2.38	6.67
2.00	1 (std.)	1.000	0.75	1.38	2.38	6.81
	2	1.375	1.00	1.63	2.63	7.06
2.50	1 (std.)	1.000	0.75	1.38	2.38	6.93
	2	1.750	1.25	1.88	2.88	7.43
	3	1.375	1.00	1.63	2.63	7.18
3.25	1 (std.)	1.375	0.88	1.63	2.75	8.06
	2	2.000	1.25	2.00	3.13	8.43
	3	1.750	1.13	1.88	3.00	8.31
4.00	1 (std.)	1.750	1.00	1.88	3.00	8.56
	2	2.500	1.38	2.25	3.38	8.94
	3	2.000	1.13	2.00	3.13	8.68
5.00	1 (std.)	2.000	1.13	2.00	3.13	9.44
	2	3.500	1.38	2.25	3.38	9.69
	3	2.500	1.38	2.25	3.38	9.69
	4	3.000	1.38	2.25	3.38	9.69
6.00	1 (std.)	2.500	1.25	2.25	3.50	10.93
	2	4.000	1.25	2.25	3.50	10.93
	3	3.000	1.25	2.25	3.50	10.93
	4	3.500	1.25	2.25	3.50	10.93

**Style J – Maximum Operating Pressure**

Bore Ø	Maximum psi Push <sup>3</sup>			
	Rod Code			
	1	2	3	4
1.50	1400	1000	-	-
2.00	2000	1200	-	-
2.50	700	1000	700	-
3.25	800	600	800	-
4.00	1000	700	1000	-
5.00	850	800	850	450
6.00	650	400	650	400

<sup>3</sup>Maximum Pressure Rating – Push Application.





**Head Square Flange Mounting**  
**Style JB**  
 (NFPA Style MF5)

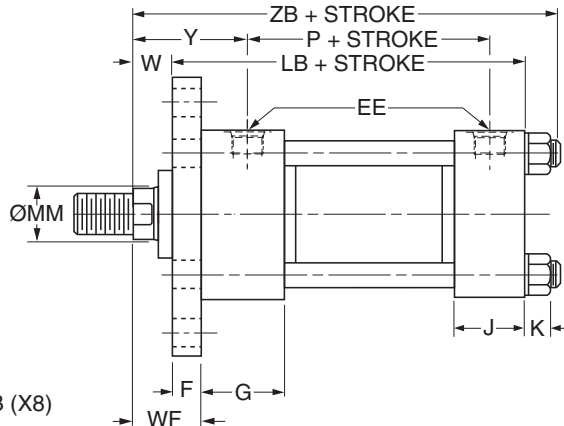
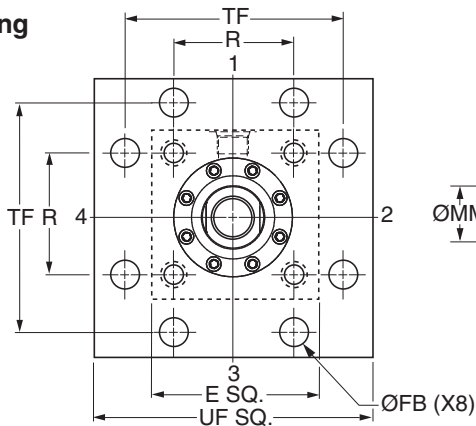
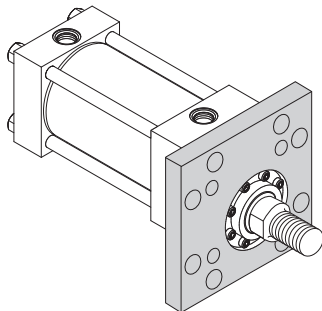

**Style JB – Dimensional and Mounting Data**

Bore Ø	E	EE		F	FB Ø	G	J	K Max.	R	TF	UF	Add Stroke	
		NPTF <sup>1</sup>	SAE <sup>2</sup>									LB	P
1.50	2.50	1/2	10 <sup>1</sup>	0.38	0.44	1.75	1.50	0.42	1.63	3.44	4.25	5.00	2.88
2.00	3.00	1/2	10 <sup>1</sup>	0.63	0.56	1.75	1.50	0.57	2.05	4.13	5.13	5.25	2.88
2.50	3.50	1/2	10 <sup>1</sup>	0.63	0.56	1.75	1.50	0.57	2.55	4.63	5.63	5.38	3.00
3.25	4.50	3/4	12	0.75	0.69	2.00	1.75	0.68	3.25	5.88	7.13	6.25	3.50
4.00	5.00	3/4	12	0.88	0.69	2.00	1.75	0.68	3.82	6.38	7.63	6.63	3.75
5.00	6.50	3/4	12	0.88	0.94	2.00	1.75	0.94	4.95	8.19	9.75	7.13	4.25
6.00	7.50	1	16	1.00	1.06	2.25	2.25	1.05	5.73	9.44	11.25	8.38	4.88

<sup>1</sup>NPTF ports are available at no extra charge.

<sup>2</sup>SAE straight thread ports are standard and are indicated by port number.

<sup>3</sup>Previously number 8 SAE in 1.50 thru 2.50 bores now number 10 SAE.

**Style JB – Dimensional and Mounting Data**

Bore Ø	Rod No.	MM Rod Ø	W	WF	Y	Add Stroke
						ZB Max.
1.50	1 (std.)	0.625	0.63	1.00	2.00	6.29
	2	1.000	1.00	1.38	2.38	6.67
2.00	1 (std.)	1.000	0.75	1.38	2.38	6.81
	2	1.375	1.00	1.63	2.63	7.06
2.50	1 (std.)	1.000	0.75	1.38	2.38	6.93
	2	1.750	1.25	1.88	2.88	7.43
	3	1.375	1.00	1.63	2.63	7.18
3.25	1 (std.)	1.375	0.88	1.63	2.75	8.06
	2	2.000	1.25	2.00	3.13	8.43
	3	1.750	1.13	1.88	3.00	8.31
4.00	1 (std.)	1.750	1.00	1.88	3.00	8.56
	2	2.500	1.38	2.25	3.38	8.94
	3	2.000	1.13	2.00	3.13	8.68
5.00	1 (std.)	2.000	1.13	2.00	3.13	9.44
	2	3.500	1.38	2.25	3.38	9.69
	3	2.500	1.38	2.25	3.38	9.69
	4	3.000	1.38	2.25	3.38	9.69
6.00	1 (std.)	2.500	1.25	2.25	3.50	10.93
	2	4.000	1.25	2.25	3.50	10.93
	3	3.000	1.25	2.25	3.50	10.93
	4	3.500	1.25	2.25	3.50	10.93

**Style JB – Maximum Operating Pressure**

Bore Ø	Maximum psi Push <sup>3</sup>			
	Rod Code			
	1	2	3	4
1.50	3000	3000	-	-
2.00	3000	3000	-	-
2.50	3000	3000	3000	-
3.25	3000	3000	3000	-
4.00	3000	3000	3000	-
5.00	2500	2300	2500	1800
6.00	2000	1600	2000	1600

<sup>3</sup>Maximum Pressure Rating – Push Application.

1.50" - 6.00" Bore  
 H Series  
**B**



**Head Rectangular Mounting**  
**Style JJ**  
**(NFPA Style ME5)**

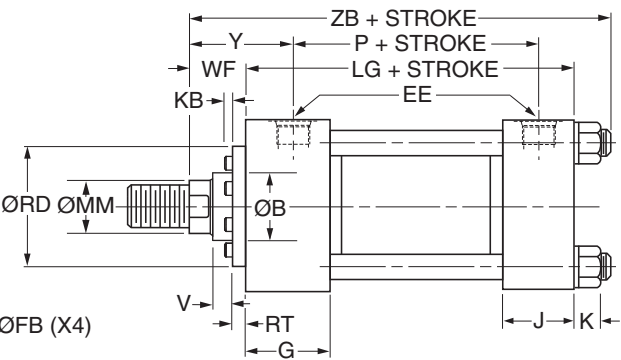
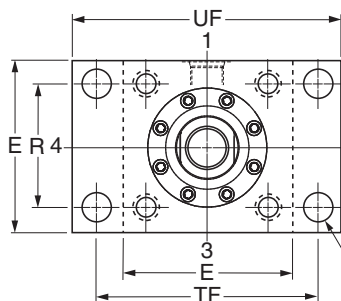
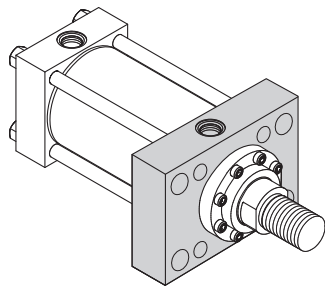

**Style JJ – Dimensional and Mounting Data**

Bore Ø	E	EE		FB Ø	G	J	K Max.	R	TF	UF	Add Stroke	
		NPTF <sup>1</sup>	SAE <sup>2</sup>								LG	P
1.50	2.50	1/2	10 <sup>†</sup>	0.44	1.75	1.50	0.42	1.63	3.44	4.25	4.63	2.88
2.00	3.00	1/2	10 <sup>†</sup>	0.56	1.75	1.50	0.57	2.05	4.13	5.13	4.63	2.88
2.50	3.50	1/2	10 <sup>†</sup>	0.56	1.75	1.50	0.57	2.55	4.63	5.63	4.75	3.00
3.25	4.50	3/4	12	0.69	2.00	1.75	0.68	3.25	5.88	7.13	5.50	3.50
4.00	5.00	3/4	12	0.69	2.00	1.75	0.68	3.82	6.38	7.63	5.75	3.75
5.00	6.50	3/4	12	0.94	2.00	1.75	0.94	4.95	8.19	9.75	6.25	4.25
6.00	7.50	1	16	1.06	2.25	2.25	1.05	5.73	9.44	11.25	7.38	4.88

<sup>1</sup>NPTF ports are available at no extra charge.

<sup>2</sup>SAE straight thread ports are standard and are indicated by port number.

<sup>†</sup>Previously number 8 SAE in 1.50 thru 2.50 bores now number 10 SAE.

**Style JJ – Dimensional and Mounting Data**

Bore Ø	Rod No.	MM Rod Ø	B Ø +.000 -.002	KB	RD Ø	RT	V	WF	Y	Add Stroke
										ZB Max
1.50	1 (std.)	0.625	1.124	0.03	1.94	0.36	0.27	1.00	2.00	6.29
	2	1.000	1.499	0.03	2.38	0.36	0.52	1.38	2.38	6.67
2.00	1 (std.)	1.000	1.499	0.03	2.38	0.36	0.52	1.38	2.38	6.81
	2	1.375	1.999	0.19	2.87	0.36	0.64	1.63	2.63	7.06
2.50	1 (std.)	1.000	1.499	0.03	2.38	0.36	0.52	1.38	2.38	6.93
	2	1.750	2.374	0.03	3.47	0.60	0.53	1.88	2.88	7.43
	3	1.375	1.999	0.19	2.87	0.36	0.64	1.63	2.63	7.18
3.25	1 (std.)	1.375	1.999	0.19	2.87	0.36	0.64	1.63	2.75	8.06
	2	2.000	2.624	0.13	3.72	0.60	0.53	2.00	3.13	8.43
	3	1.750	2.374	0.03	3.47	0.60	0.53	1.88	3.00	8.31
4.00	1 (std.)	1.750	2.374	0.03	3.47	0.60	0.53	1.88	3.00	8.56
	2	2.500	3.124	0.25	4.25	0.60	0.65	2.25	3.38	8.94
	3	2.000	2.624	0.13	3.72	0.60	0.53	2.00	3.13	8.68
5.00	1 (std.)	2.000	2.624	0.13	3.72	0.60	0.53	2.00	3.13	9.44
	2	3.500	4.249	-	5.76	0.91	0.34	2.25	3.38	9.69
	3	2.500	3.124	0.25	4.25	0.60	0.65	2.25	3.38	9.69
	4	3.000	3.749	-	5.26	0.85	0.41	2.25	3.38	9.69
6.00	1 (std.)	2.500	3.124	0.25	4.25	0.60	0.65	2.25	3.50	10.93
	2	4.000	4.749	-	6.31	0.91	0.34	2.25	3.50	10.93
	3	3.000	3.749	-	5.26	0.85	0.41	2.25	3.50	10.93
	4	3.500	4.249	-	5.76	0.91	0.34	2.25	3.50	10.93

**H Series**  
**1.50" - 6.00" Bore**

**Cap Rectangular Flange Mounting**  
 Style H  
 (NFPA Style MF2)

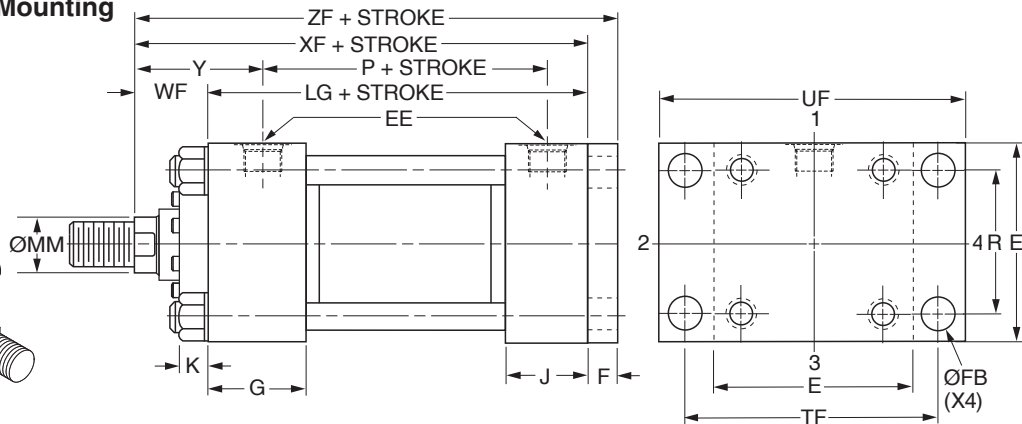
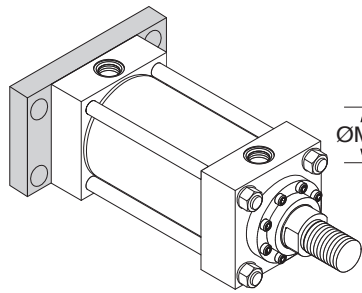

**Style H – Dimensional and Mounting Data**

Bore Ø	E	EE		F	FB Ø	G	J	K Max.	R	TF	UF	Add Stroke	
		NPTF <sup>1</sup>	SAE <sup>2</sup>									LG	P
1.50	2.50	1/2	10 <sup>†</sup>	0.38	0.44	1.75	1.50	0.42	1.63	3.44	4.25	4.63	2.88
2.00	3.00	1/2	10 <sup>†</sup>	0.63	0.56	1.75	1.50	0.57	2.05	4.13	5.13	4.63	2.88
2.50	3.50	1/2	10 <sup>†</sup>	0.63	0.56	1.75	1.50	0.57	2.55	4.63	5.63	4.75	3.00
3.25	4.50	3/4	12	0.75	0.69	2.00	1.75	0.68	3.25	5.88	7.13	5.50	3.50
4.00	5.00	3/4	12	0.88	0.69	2.00	1.75	0.68	3.82	6.38	7.63	5.75	3.75
5.00	6.50	3/4	12	0.88	0.94	2.00	1.75	0.94	4.95	8.19	9.75	6.25	4.25
6.00	7.50	1	16	1.00	1.06	2.25	2.25	1.05	5.73	9.44	11.25	7.38	4.88

<sup>1</sup>NPTF ports are available at no extra charge.

<sup>2</sup>SAE straight thread ports are standard and are indicated by port number.

<sup>†</sup>Previously number 8 SAE in 1.50 thru 2.50 bores now number 10 SAE.

**Style H – Dimensional and Mounting Data**

Bore Ø	Rod No.	MM Rod Ø	WF	Y	Add Stroke	
					XF	ZF
1.50	1 (std.)	0.625	1.00	2.00	5.63	6.00
	2	1.000	1.38	2.38	6.00	6.38
2.00	1 (std.)	1.000	1.38	2.38	6.00	6.63
	2	1.375	1.63	2.63	6.25	6.88
2.50	1 (std.)	1.000	1.38	2.38	6.13	6.75
	2	1.750	1.88	2.88	6.63	7.25
	3	1.375	1.63	2.63	6.38	7.00
3.25	1 (std.)	1.375	1.63	2.75	7.13	7.88
	2	2.000	2.00	3.13	7.50	8.25
	3	1.750	1.88	3.00	7.38	8.13
4.00	1 (std.)	1.750	1.88	3.00	7.63	8.50
	2	2.500	2.25	3.38	8.00	8.88
	3	2.000	2.00	3.13	7.75	8.63
5.00	1 (std.)	2.000	2.00	3.13	8.25	9.13
	2	3.500	2.25	3.38	8.50	9.38
	3	2.500	2.25	3.38	8.50	9.38
	4	3.000	2.25	3.38	8.50	9.38
6.00	1 (std.)	2.500	2.25	3.50	9.63	10.63
	2	4.000	2.25	3.50	9.63	10.63
	3	3.000	2.25	3.50	9.63	10.63
	4	3.500	2.25	3.50	9.63	10.63

**Style H – Maximum Operating Pressure**

Bore Ø	Maximum psi Pull <sup>3</sup>			
	Rod Code			
	1	2	3	4
1.50	2500	3000	-	-
2.00	3000	3000	-	-
2.50	3000	3000	3000	-
3.25	3000	3000	3000	-
4.00	3000	3000	3000	-
5.00	2000	3000	2000	2500
6.00	1800	2500	2000	2000

<sup>3</sup>Maximum pressure rating — pull application.

H Series  
 1.50" - 6.00" Bore

**Cap Square Flange Mounting**

Style HB  
(NFPA Style MF6)

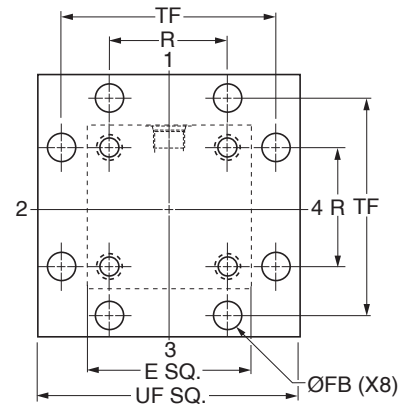
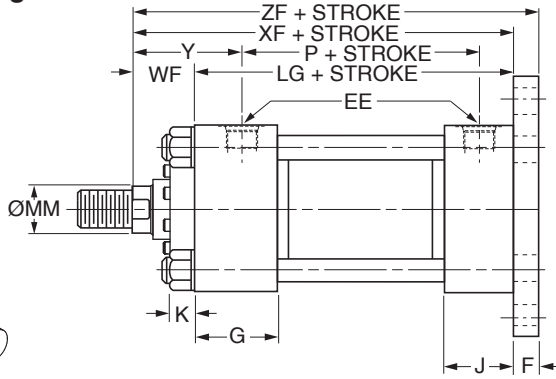
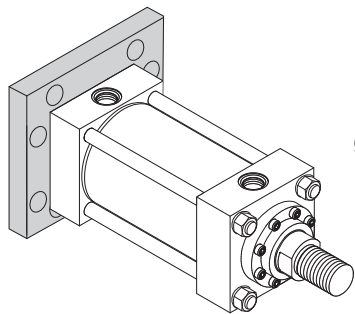

**Style HB – Dimensional and Mounting Data**

Bore Ø	E	EE		F	FB Ø	G	J	K Max.	R	TF	UF	Add Stroke	
		NPTF <sup>1</sup>	SAE <sup>2</sup>									LG	P
1.50	2.50	1/2	10 <sup>†</sup>	0.38	0.44	1.75	1.50	0.42	1.63	3.44	4.25	4.63	2.88
2.00	3.00	1/2	10 <sup>†</sup>	0.63	0.56	1.75	1.50	0.57	2.05	4.13	5.13	4.63	2.88
2.50	3.50	1/2	10 <sup>†</sup>	0.63	0.56	1.75	1.50	0.57	2.55	4.63	5.63	4.75	3.00
3.25	4.50	3/4	12	0.75	0.69	2.00	1.75	0.68	3.25	5.88	7.13	5.50	3.50
4.00	5.00	3/4	12	0.88	0.69	2.00	1.75	0.68	3.82	6.38	7.63	5.75	3.75
5.00	6.50	3/4	12	0.88	0.94	2.00	1.75	0.94	4.95	8.19	9.75	6.25	4.25
6.00	7.50	1	16	1.00	1.06	2.25	2.25	1.05	5.73	9.44	11.25	7.38	4.88

<sup>1</sup>NPTF ports are available at no extra charge.

<sup>2</sup>SAE straight thread ports are standard and are indicated by port number.

<sup>†</sup>Previously number 8 SAE in 1.50 thru 2.50 bores now number 10 SAE.

**Style HB – Dimensional and Mounting Data**

Bore Ø	Rod No.	MM Rod Ø	WF	Y	Add Stroke	
					XF	ZF
1.50	1 (std.)	0.625	1.00	2.00	5.63	6.00
	2	1.000	1.38	2.38	6.00	6.38
2.00	1 (std.)	1.000	1.38	2.38	6.00	6.63
	2	1.375	1.63	2.63	6.25	6.88
2.50	1 (std.)	1.000	1.38	2.38	6.13	6.75
	2	1.750	1.88	2.88	6.63	7.25
	3	1.375	1.63	2.63	6.38	7.00
3.25	1 (std.)	1.375	1.63	2.75	7.13	7.88
	2	2.000	2.00	3.13	7.50	8.25
	3	1.750	1.88	3.00	7.38	8.13
4.00	1 (std.)	1.750	1.88	3.00	7.63	8.50
	2	2.500	2.25	3.38	8.00	8.88
	3	2.000	2.00	3.13	7.75	8.63
5.00	1 (std.)	2.000	2.00	3.13	8.25	9.13
	2	3.500	2.25	3.38	8.50	9.38
	3	2.500	2.25	3.38	8.50	9.38
	4	3.000	2.25	3.38	8.50	9.38
6.00	1 (std.)	2.500	2.25	3.50	9.63	10.63
	2	4.000	2.25	3.50	9.63	10.63
	3	3.000	2.25	3.50	9.63	10.63
	4	3.500	2.25	3.50	9.63	10.63

**H Series**  
**1.50" - 6.00" Bore**

**Cap Rectangular Flange Mounting**  
 Style HH  
 (NFPA Style ME6)

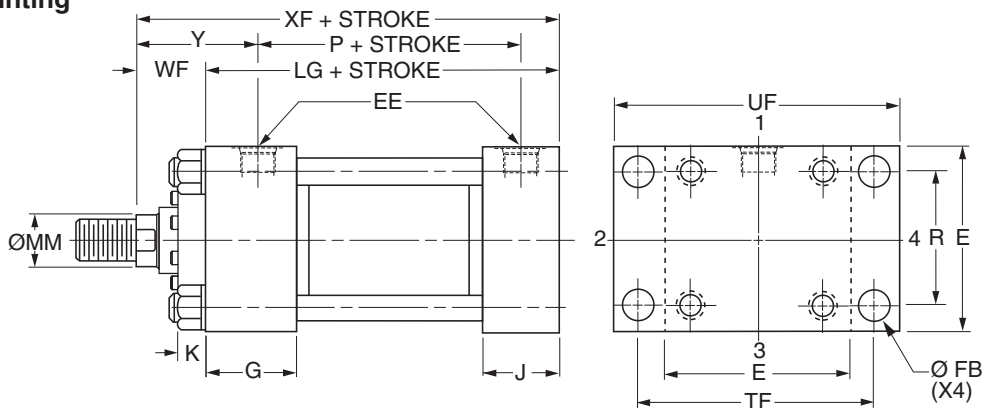
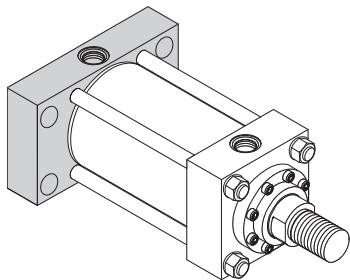

**Style HH – Dimensional and Mounting Data**

Bore Ø	E	EE		FB Ø	G	J	K Max.	R	TF	UF	Add Stroke	
		NPTF <sup>1</sup>	SAE <sup>2</sup>								LG	P
1.50	2.50	1/2	10 <sup>†</sup>	0.44	1.75	1.50	0.42	1.63	3.44	4.25	4.63	2.88
2.00	3.00	1/2	10 <sup>†</sup>	0.56	1.75	1.50	0.57	2.05	4.13	5.13	4.63	2.88
2.50	3.50	1/2	10 <sup>†</sup>	0.56	1.75	1.50	0.57	2.55	4.63	5.63	4.75	3.00
3.25	4.50	3/4	12	0.69	2.00	1.75	0.68	3.25	5.88	7.13	5.50	3.50
4.00	5.00	3/4	12	0.69	2.00	1.75	0.68	3.82	6.38	7.63	5.75	3.75
5.00	6.50	3/4	12	0.94	2.00	1.75	0.94	4.95	8.19	9.75	6.25	4.25
6.00	7.50	1	16	1.06	2.25	2.25	1.05	5.73	9.44	11.25	7.38	4.88

<sup>1</sup>NPTF ports are available at no extra charge.

<sup>2</sup>SAE straight thread ports are standard and are indicated by port number.

<sup>†</sup>Previously number 8 SAE in 1.50 thru 2.50 bores now number 10 SAE.

**Style HH – Dimensional and Mounting Data**

Bore Ø	Rod No.	MM Rod Ø	WF	Y	Add Stroke
					XF
1.50	1 (std.)	0.625	1.00	2.00	5.63
	2	1.000	1.38	2.38	6.00
2.00	1 (std.)	1.000	1.38	2.38	6.00
	2	1.375	1.63	2.63	6.25
2.50	1 (std.)	1.000	1.38	2.38	6.13
	2	1.750	1.88	2.88	6.63
	3	1.375	1.63	2.63	6.38
3.25	1 (std.)	1.375	1.63	2.75	7.13
	2	2.000	2.00	3.13	7.50
	3	1.750	1.88	3.00	7.38
4.00	1 (std.)	1.750	1.88	3.00	7.63
	2	2.500	2.25	3.38	8.00
	3	2.000	2.00	3.13	7.75
5.00	1 (std.)	2.000	2.00	3.13	8.25
	2	3.500	2.25	3.38	8.50
	3	2.500	2.25	3.38	8.50
	4	3.000	2.25	3.38	8.50
6.00	1 (std.)	2.500	2.25	3.50	9.63
	2	4.000	2.25	3.50	9.63
	3	3.000	2.25	3.50	9.63
	4	3.500	2.25	3.50	9.63

1.50" - 6.00" Bore  
 H Series  
**B**

**Side Lug Mounting**  
 Style C  
 (NFPA Style MS2)

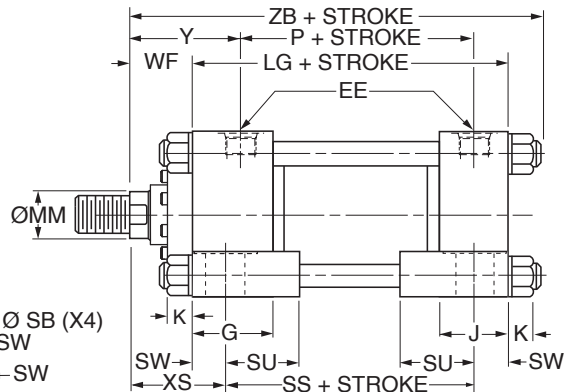
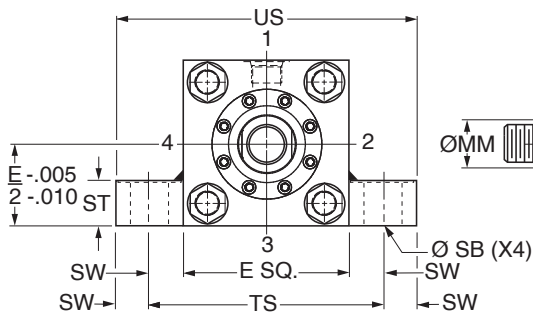
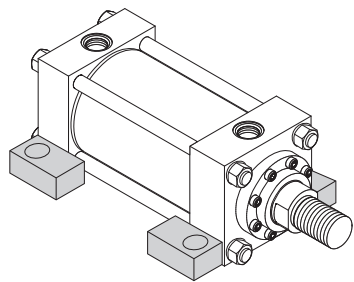

**Style C – Dimensional and Mounting Data**

Bore Ø	E	EE		G	J	K Max.	SB <sup>3</sup> Ø	ST	SU	SW	TS	US	Add Stroke		
		NPTF <sup>1</sup>	SAE <sup>2</sup>										LG	P	SS
1.50	2.50	1/2	10 <sup>†</sup>	1.75	1.50	0.42	0.44	0.50	0.94	0.38	3.25	4.00	4.63	2.88	3.88
2.00	3.00	1/2	10 <sup>†</sup>	1.75	1.50	0.57	0.56	0.75	1.25	0.50	4.00	5.00	4.63	2.88	3.63
2.50	3.50	1/2	10 <sup>†</sup>	1.75	1.50	0.57	0.81	1.00	1.56	0.69	4.88	6.25	4.75	3.00	3.38
3.25	4.50	3/4	12	2.00	1.75	0.68	0.81	1.00	1.56	0.69	5.88	7.25	5.50	3.50	4.13
4.00	5.00	3/4	12	2.00	1.75	0.68	1.06	1.25	2.00	0.88	6.75	8.50	5.75	3.75	4.00
5.00	6.50	3/4	12	2.00	1.75	0.94	1.06	1.25	2.00	0.88	8.25	10.00	6.25	4.25	4.50
6.00	7.50	1	16	2.25	2.25	1.05	1.31	1.50	2.50	1.13	9.75	12.00	7.38	4.88	5.13

<sup>1</sup>NPTF ports are available at no extra charge.

<sup>2</sup>SAE straight thread ports are standard and are indicated by port number.

<sup>3</sup>Upper surface spot faced for socket head screws.

<sup>†</sup>Previously number 8 SAE in 1.50 thru 2.50 bores now number 10 SAE.

**Style C – Dimensional and Mounting Data**

Bore Ø	Rod No.	MM Rod Ø	WF	XS	Y	Add Stroke
						ZB Max.
1.50	1 (std.)	0.625	1.00	1.38	2.00	6.29
	2	1.000	1.38	1.75	2.38	6.67
2.00	1 (std.)	1.000	1.38	1.88	2.38	6.81
	2	1.375	1.63	2.13	2.63	7.06
2.50	1 (std.)	1.000	1.38	2.06	2.38	6.93
	2	1.750	1.88	2.56	2.88	7.43
	3	1.375	1.63	2.31	2.63	7.18
3.25	1 (std.)	1.375	1.63	2.31	2.75	8.06
	2	2.000	2.00	2.69	3.13	8.43
	3	1.750	1.88	2.56	3.00	8.31
4.00	1 (std.)	1.750	1.88	2.75	3.00	8.56
	2	2.500	2.25	3.13	3.38	8.94
	3	2.000	2.00	2.88	3.13	8.68
5.00	1 (std.)	2.000	2.00	2.88	3.13	9.44
	2	3.500	2.25	3.13	3.38	9.69
	3	2.500	2.25	3.13	3.38	9.69
	4	3.000	2.25	3.13	3.38	9.69
6.00	1 (std.)	2.500	2.25	3.38	3.50	10.93
	2	4.000	2.25	3.38	3.50	10.93
	3	3.000	2.25	3.38	3.50	10.93
	4	3.500	2.25	3.38	3.50	10.93

 H Series  
 1.50" - 6.00" Bore

**Side Tapped Mounting**  
**Style F**  
 (NFPA Style MS4)

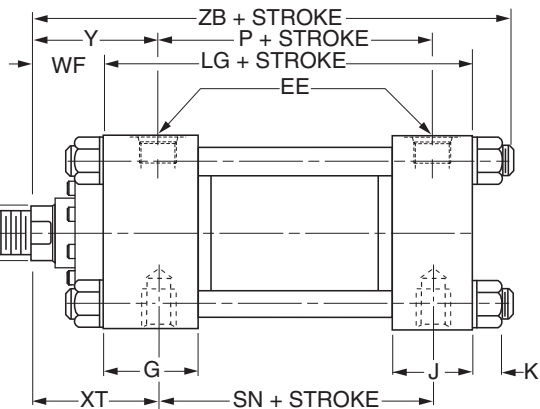
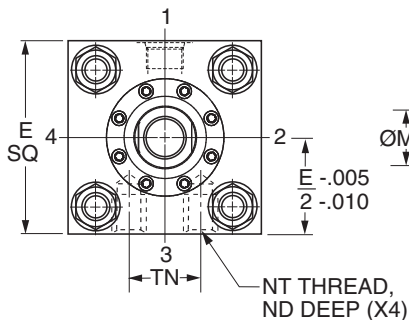
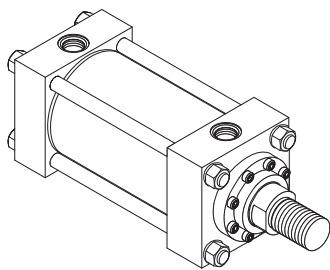

**Style F – Dimensional and Mounting Data**

Bore Ø	E	EE		G	J	K Max.	ND	NT	TN	Add Stroke		
		NPTF <sup>1</sup>	SAE <sup>2</sup>							LG	P	SN
1.50	2.50	1/2	10 <sup>†</sup>	1.75	1.50	0.42	0.38	3/8-16	0.75	4.63	2.88	2.88
2.00	3.00	1/2	10 <sup>†</sup>	1.75	1.50	0.57	0.44	1/2-13	0.94	4.63	2.88	2.88
2.50	3.50	1/2	10 <sup>†</sup>	1.75	1.50	0.57	0.50	5/8-11	1.31	4.75	3.00	3.00
3.25	4.50	3/4	12	2.00	1.75	0.68	0.69	3/4-10	1.50	5.50	3.50	3.50
4.00	5.00	3/4	12	2.00	1.75	0.68	0.69	1-8	2.06	5.75	3.75	3.75
5.00	6.50	3/4	12	2.00	1.75	0.94	1.00	1-8	2.94	6.25	4.25	4.25
6.00	7.50	1	16	2.25	2.25	1.05	1.25	1 1/4 -7	3.31	7.38	4.88	5.13

<sup>1</sup>NPTF ports are available at no extra charge.

<sup>2</sup>SAE straight thread ports are standard and are indicated by port number.

<sup>†</sup>Previously number 8 SAE in 1.50 thru 2.50 bores now number 10 SAE.

**Style F – Dimensional and Mounting Data**

Bore Ø	Rod No.	MM Rod Ø	WF	XT	Y	Add Stroke
						ZB Max.
1.50	1 (std.)	0.625	1.00	2.00	2.00	6.29
	2	1.000	1.38	2.38	2.38	6.67
2.00	1 (std.)	1.000	1.38	2.38	2.38	6.81
	2	1.375	1.63	2.63	2.63	7.06
2.50	1 (std.)	1.000	1.38	2.38	2.38	6.93
	2	1.750	1.88	2.88	2.88	7.43
	3	1.375	1.63	2.63	2.63	7.18
3.25	1 (std.)	1.375	1.63	2.75	2.75	8.06
	2	2.000	2.00	3.13	3.13	8.43
	3	1.750	1.88	3.00	3.00	8.31
4.00	1 (std.)	1.750	1.88	3.00	3.00	8.56
	2	2.500	2.25	3.38	3.38	8.94
	3	2.000	2.00	3.13	3.13	8.68
5.00	1 (std.)	2.000	2.00	3.13	3.13	9.44
	2	3.500	2.25	3.38	3.38	9.69
	3	2.500	2.25	3.38	3.38	9.69
	4	3.000	2.25	3.38	3.38	9.69
6.00	1 (std.)	2.500	2.25	3.50	3.50	10.93
	2	4.000	2.25	3.50	3.50	10.93
	3	3.000	2.25	3.50	3.50	10.93
	4	3.500	2.25	3.50	3.50	10.93

H Series  
 1.50" - 6.00" Bore

**Cap Fixed Clevis Mounting**  
 Style BB  
 (NFPA Style MP1)

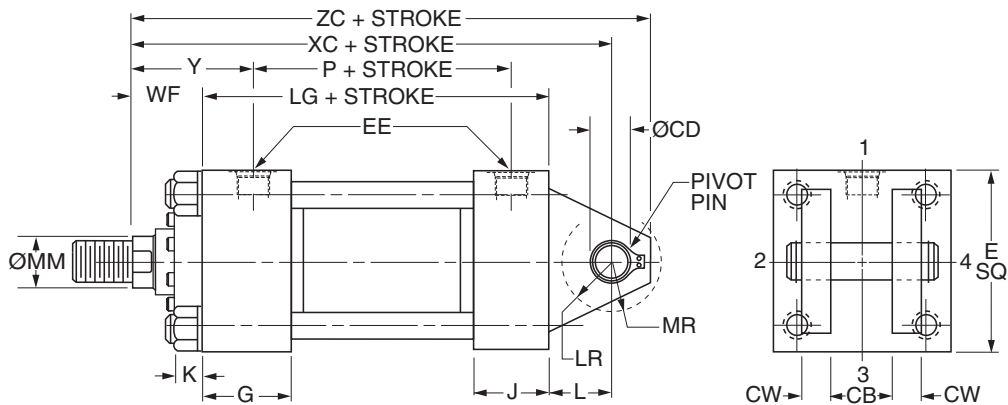
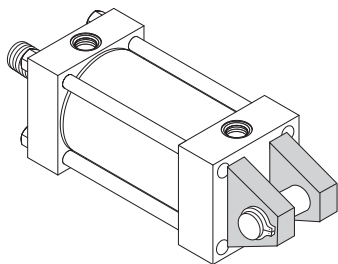

**Style BB – Dimensional and Mounting Data**

Bore Ø	E	EE		CB	CD <sup>3</sup> Ø +0.000 -0.002	CW	G	J	K Max.	L	LR	MR	Add Stroke	
		NPTF <sup>1</sup>	SAE <sup>2</sup>										LG	P
1.50	2.50	1/2	10 <sup>†</sup>	0.75	.501	0.50	1.75	1.50	0.42	0.75	0.56	0.63	4.63	2.88
2.00	3.00	1/2	10 <sup>†</sup>	1.25	.751	0.63	1.75	1.50	0.57	1.25	1.00	0.94	4.63	2.88
2.50	3.50	1/2	10 <sup>†</sup>	1.25	.751	0.63	1.75	1.50	0.57	1.25	0.94	0.94	4.75	3.00
3.25	4.50	3/4	12	1.50	1.001	0.75	2.00	1.75	0.68	1.50	1.25	1.19	5.50	3.50
4.00	5.00	3/4	12	2.00	1.376	1.00	2.00	1.75	0.68	2.13	1.75	1.63	5.75	3.75
5.00	6.50	3/4	12	2.50	1.751	1.25	2.00	1.75	0.94	2.25	2.06	2.13	6.25	4.25
6.00	7.50	1	16	2.50	2.001	1.25	2.25	2.25	1.05	2.50	2.31	2.38	7.38	4.88

<sup>1</sup>NPTF ports are available at no extra charge.

<sup>2</sup>SAE straight thread ports are standard and are indicated by port number.

<sup>3</sup>Diameter CD is Pin Diameter.

<sup>†</sup>Previously number 8 SAE in 1.50 thru 2.50 bores now number 10 SAE.

**Style BB – Dimensional and Mounting Data**

Bore Ø	Rod No.	MM Rod Ø	WF	Y	Add Stroke	
					XC	ZC
1.50	1 (std.)	0.625	1.00	2.00	6.38	6.88
	2	1.000	1.38	2.38	6.75	7.25
2.00	1 (std.)	1.000	1.38	2.38	7.25	8.00
	2	1.375	1.63	2.63	7.50	8.25
2.50	1 (std.)	1.000	1.38	2.38	7.38	8.13
	2	1.750	1.88	2.88	7.88	8.63
	3	1.375	1.63	2.63	7.63	8.38
3.25	1 (std.)	1.375	1.63	2.75	8.63	9.63
	2	2.000	2.00	3.13	9.00	10.00
	3	1.750	1.88	3.00	8.88	9.88
4.00	1 (std.)	1.750	1.88	3.00	9.75	11.13
	2	2.500	2.25	3.38	10.13	11.50
	3	2.000	2.00	3.13	9.88	11.25
5.00	1 (std.)	2.000	2.00	3.13	10.50	12.25
	2	3.500	2.25	3.38	10.75	12.50
	3	2.500	2.25	3.38	10.75	12.50
	4	3.000	2.25	3.38	10.75	12.50
6.00	1 (std.)	2.500	2.25	3.50	12.13	14.13
	2	4.000	2.25	3.50	12.13	14.13
	3	3.000	2.25	3.50	12.13	14.13
	4	3.500	2.25	3.50	12.13	14.13





**Head Trunnion Mounting**  
**Style D**  
(NFPA Style MT1)

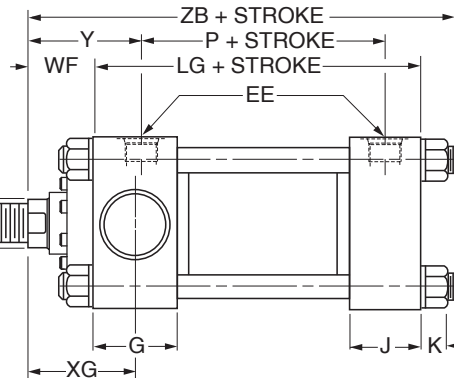
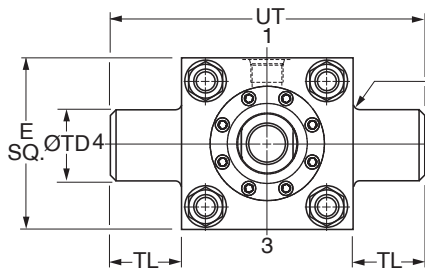
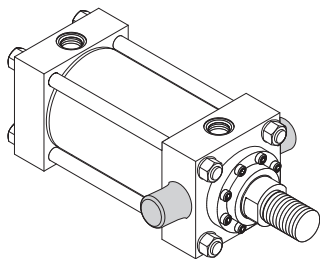

**Style D – Dimensional and Mounting Data**

Bore Ø	E	EE		G	J	K Max.	TD Ø +.000 -.001	TL	UT	Add Stroke	
		NPTF <sup>1</sup>	SAE <sup>2</sup>							LG	P
1.50	2.50	1/2	10 <sup>3</sup>	1.75	1.50	0.42	1.000	1.00	4.50	4.63	2.88
2.00	3.00	1/2	10 <sup>3</sup>	1.75	1.50	0.57	1.375	1.38	5.75	4.63	2.88
2.50	3.50	1/2	10 <sup>3</sup>	1.75	1.50	0.57	1.375	1.38	6.25	4.75	3.00
3.25	4.50	3/4	12	2.00	1.75	0.68	1.750	1.75	8.00	5.50	3.50
4.00	5.00	3/4	12	2.00	1.75	0.68	1.750	1.75	8.50	5.75	3.75
5.00	6.50	3/4	12	2.00	1.75	0.94	1.750	1.75	10.00	6.25	4.25
6.00	7.50	1	16	2.25	2.25	1.05	2.000	2.00	11.50	7.38	4.88

<sup>1</sup>NPTF ports are available at no extra charge.

<sup>2</sup>SAE straight thread ports are standard and are indicated by port number.

<sup>3</sup>Previously number 8 SAE in 1.50 thru 2.50 bores now number 10 SAE.

**Style D – Dimensional and Mounting Data**

Bore Ø	Rod No.	MM Rod Ø	WF	XG	Y	Add Stroke
						ZB Max.
1.50	1 (std.)	0.625	1.00	1.88	2.00	6.29
	2	1.000	1.38	2.25	2.38	6.67
2.00	1 (std.)	1.000	1.38	2.25	2.38	6.81
	2	1.375	1.63	2.50	2.63	7.06
2.50	1 (std.)	1.000	1.38	2.25	2.38	6.93
	2	1.750	1.88	2.75	2.88	7.43
	3	1.375	1.63	2.50	2.63	7.18
3.25	1 (std.)	1.375	1.63	2.63	2.75	8.06
	2	2.000	2.00	3.00	3.13	8.43
	3	1.750	1.88	2.88	3.00	8.31
4.00	1 (std.)	1.750	1.88	2.88	3.00	8.56
	2	2.500	2.25	3.25	3.38	8.94
	3	2.000	2.00	3.00	3.13	8.68
5.00	1 (std.)	2.000	2.00	3.00	3.13	9.44
	2	3.500	2.25	3.25	3.38	9.69
	3	2.500	2.25	3.25	3.38	9.69
	4	3.000	2.25	3.25	3.38	9.69
6.00	1 (std.)	2.500	2.25	3.38	3.50	10.93
	2	4.000	2.25	3.38	3.50	10.93
	3	3.000	2.25	3.38	3.50	10.93
	4	3.500	2.25	3.38	3.50	10.93

**B**  
H Series  
1.50" - 6.00" Bore

**Cap Trunnion Mounting**

Style DB  
 (NFPA Style MT2)

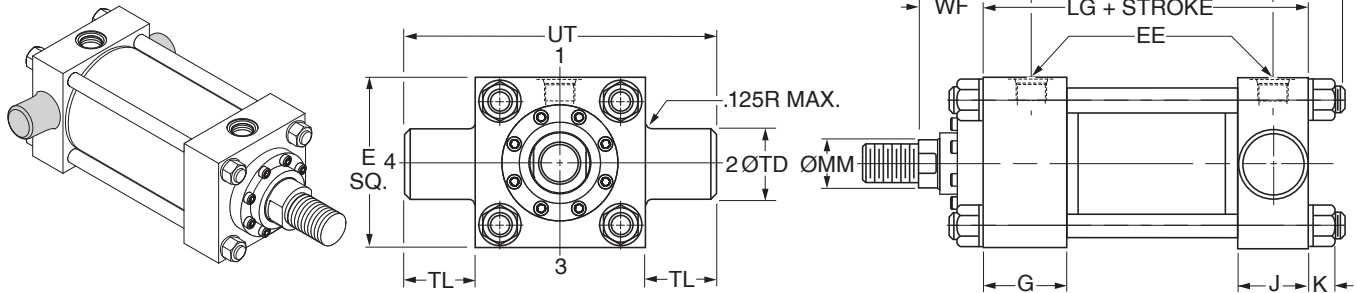

**Style DB – Dimensional and Mounting Data**

Bore Ø	E	EE		G	J	K Max.	TD Ø +.000 -.001	TL	UT	Add Stroke	
		NPTF <sup>1</sup>	SAE <sup>2</sup>							LG	P
1.50	2.50	1/2	10 <sup>3</sup>	1.75	1.50	0.42	1.000	1.00	4.50	4.63	2.88
2.00	3.00	1/2	10 <sup>3</sup>	1.75	1.50	0.57	1.375	1.38	5.75	4.63	2.88
2.50	3.50	1/2	10 <sup>3</sup>	1.75	1.50	0.57	1.375	1.38	6.25	4.75	3.00
3.25	4.50	3/4	12	2.00	1.75	0.68	1.750	1.75	8.00	5.50	3.50
4.00	5.00	3/4	12	2.00	1.75	0.68	1.750	1.75	8.50	5.75	3.75
5.00	6.50	3/4	12	2.00	1.75	0.94	1.750	1.75	10.00	6.25	4.25
6.00	7.50	1	16	2.25	2.25	1.05	2.000	2.00	11.50	7.38	4.88

<sup>1</sup>NPTF ports are available at no extra charge.

<sup>2</sup>SAE straight thread ports are standard and are indicated by port number.

<sup>3</sup>Previously number 8 SAE in 1.50 thru 2.50 bores now number 10 SAE.

**Style DB – Dimensional and Mounting Data**

Bore Ø	Rod No.	MM Rod Ø	WF	Y	Add Stroke	
					XJ	ZB Max.
1.50	1 (std.)	0.625	1.00	2.00	4.88	6.29
	2	1.000	1.38	2.38	5.25	6.67
2.00	1 (std.)	1.000	1.38	2.38	5.25	6.81
	2	1.375	1.63	2.63	5.50	7.06
2.50	1 (std.)	1.000	1.38	2.38	5.38	6.93
	2	1.750	1.88	2.88	5.88	7.43
	3	1.375	1.63	2.63	5.63	7.18
3.25	1 (std.)	1.375	1.63	2.75	6.25	8.06
	2	2.000	2.00	3.13	6.63	8.43
	3	1.750	1.88	3.00	6.50	8.31
4.00	1 (std.)	1.750	1.88	3.00	6.75	8.56
	2	2.500	2.25	3.38	7.13	8.94
	3	2.000	2.00	3.13	6.88	8.68
5.00	1 (std.)	2.000	2.00	3.13	7.38	9.44
	2	3.500	2.25	3.38	7.63	9.69
	3	2.500	2.25	3.38	7.63	9.69
	4	3.000	2.25	3.38	7.63	9.69
6.00	1 (std.)	2.500	2.25	3.50	8.38	10.93
	2	4.000	2.25	3.50	8.38	10.93
	3	3.000	2.25	3.50	8.38	10.93
	4	3.500	2.25	3.50	8.38	10.93

**B**  
 H Series  
 1.50" - 6.00" Bore

**Intermediate Fixed Trunnion Mounting**  
 Style DD  
 (NPTA Style MT4)

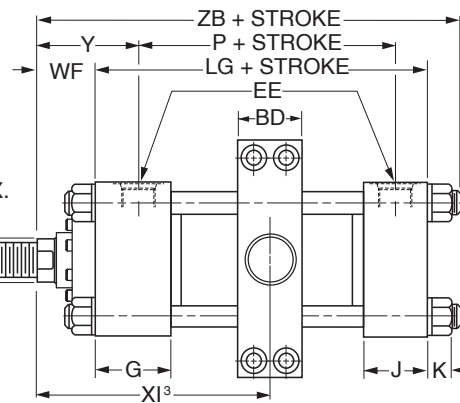
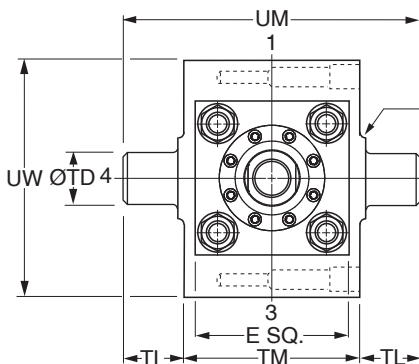
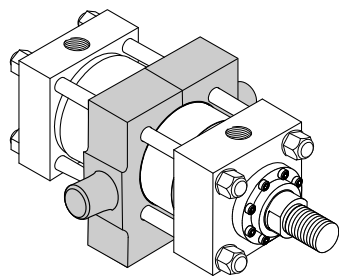

**Style DD – Dimensional and Mounting Data**

Bore Ø	BD	E	EE		G	J	K Max.	TD Ø +.000 -.001	TL	TM	UM	UW	Add Stroke	
			NPTF <sup>1</sup>	SAE <sup>2</sup>									LG	P
1.50	1.25	2.50	1/2	10 <sup>1</sup>	1.75	1.50	0.42	1.000	1.00	3.00	5.00	3.38	4.63	2.88
2.00	1.50	3.00	1/2	10 <sup>1</sup>	1.75	1.50	0.57	1.375	1.38	3.50	6.25	4.13	4.63	2.88
2.50	1.50	3.50	1/2	10 <sup>1</sup>	1.75	1.50	0.57	1.375	1.38	4.00	6.75	4.63	4.75	3.00
3.25	2.00	4.50	3/4	12	2.00	1.75	0.68	1.750	1.75	5.00	8.50	5.81	5.50	3.50
4.00	2.00	5.00	3/4	12	2.00	1.75	0.68	1.750	1.75	5.50	9.00	6.38	5.75	3.75
5.00	2.00	6.50	3/4	12	2.00	1.75	0.94	1.750	1.75	7.00	10.50	7.75	6.25	4.25
6.00	3.00	7.50	1	16	2.25	2.25	1.05	2.000	2.00	8.50	12.50	10.38	7.38	4.88

<sup>1</sup>NPTF ports are available at no extra charge.

<sup>2</sup>SAE straight thread ports are standard and are indicated by port number.

<sup>3</sup>Previously number 8 SAE in 1.50 thru 2.50 bores now number 10 SAE.

**Style DD – Dimensional and Mounting Data**

Bore Ø	Rod No.	MM Rod Ø	WF	Y	Minimum XI <sup>3</sup>		Style DD Min. Stroke	Add Stroke		
					Styles 4, 8 & 9	Style 55		Maximum XI <sup>4</sup>		ZB Max
								Styles 4, 8 & 9	Style 55	
1.50	1 (std.)	0.625	1.00	2.00	3.44	4.19	0	3.44	4.19	6.29
	2	1.000	1.38	2.38	3.81	4.81	0	3.81	4.81	6.67
2.00	1 (std.)	1.000	1.38	2.38	3.94	4.94	0.25	3.69	4.69	6.81
	2	1.375	1.63	2.63	4.19	5.31	0.25	3.94	5.06	7.06
2.50	1 (std.)	1.000	1.38	2.38	3.94	4.94	0.13	3.81	4.81	6.93
	2	1.750	1.88	2.88	4.44	5.69	0.13	4.31	5.56	7.43
	3	1.375	1.63	2.63	4.19	5.31	0.13	4.06	5.19	7.18
3.25	1 (std.)	1.375	1.63	2.75	4.69	5.81	0.38	4.31	5.44	8.06
	2	2.000	2.00	3.13	5.06	6.81	0.38	4.69	6.44	8.43
	3	1.750	1.88	3.00	4.94	6.19	0.38	4.56	5.81	8.31
4.00	1 (std.)	1.750	1.88	3.00	4.94	6.19	0.13	4.81	6.06	8.56
	2	2.500	2.25	3.38	5.31	7.56	0.13	5.19	7.44	8.94
	3	2.000	2.00	3.13	5.06	6.81	0.13	4.94	6.69	8.68
5.00	1 (std.)	2.000	2.00	3.13	5.06	6.81	0	5.44	7.19	9.44
	2	3.500	2.25	3.38	5.31	8.69	0	5.69	9.06	9.69
	3	2.500	2.25	3.38	5.31	7.56	0	5.69	7.94	9.69
	4	3.000	2.25	3.38	5.31	7.94	0	5.69	8.31	9.69
6.00	1 (std.)	2.500	2.25	3.50	6.06	8.31	0.25	5.81	8.06	10.93
	2	4.000	2.25	3.50	6.06	9.56	0.25	5.81	9.31	10.93
	3	3.000	2.25	3.50	6.06	8.69	0.25	5.81	8.44	10.93
	4	3.500	2.25	3.50	6.06	9.44	0.25	5.81	9.19	10.93

<sup>3</sup>Dimension XI to be specified by customer. Reference point for rod end Style 55 is end of piston rod.

<sup>4</sup>Dimensions shown are valid for standard WF and WG dimension.

1.50" - 6.00" Bore  
**B**  
 H Series

**Heavy Duty Intermediate Fixed Trunnion Mounting**

Style DE  
 (NFPA Style MT4)

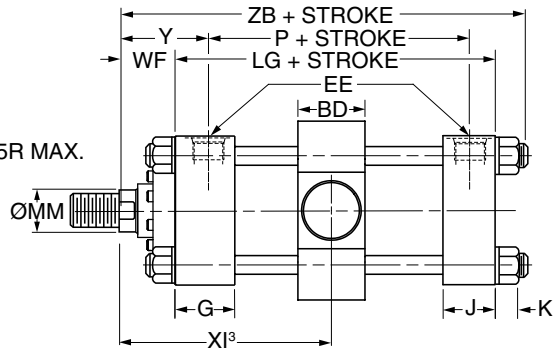
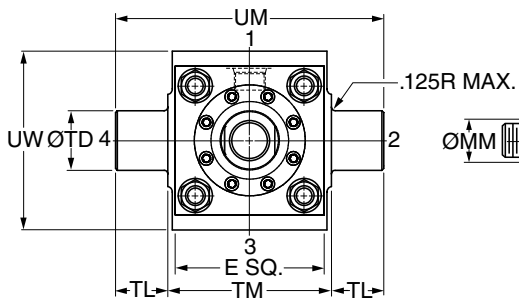
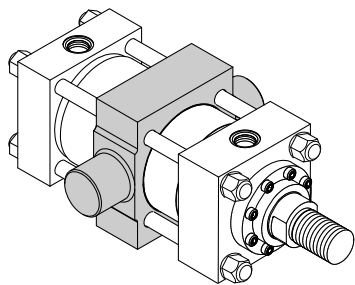

**Style DE – Dimensional and Mounting Data**

Bore Ø	BD	E	EE		G	J	K Max.	TD Ø +.000 -.001	TL	TM	UM	UW	Add Stroke	
			NPTF <sup>1</sup>	SAE <sup>2</sup>									LG	P
4.00	2.25	5.00	3/4	12	2.00	1.75	0.68	2.000	1.75	5.50	9.00	6.00	5.75	3.75
5.00	2.75	6.50	3/4	12	2.00	1.75	0.94	2.500	1.75	7.00	10.50	7.50	6.25	4.25
6.00	3.25	7.50	1	16	2.25	2.25	1.05	3.000	2.00	8.50	12.50	9.50	7.38	4.88

<sup>1</sup>NPTF ports are available at no extra charge.

<sup>2</sup>SAE straight thread ports are standard and are indicated by port number.

**Style DE – Dimensional and Mounting Data**

Bore Ø	Rod No.	MM Rod Ø	WF	Y	Minimum XI <sup>3</sup>		Style DE Minimum Stroke	Add Stroke		
					Styles 4, 8 & 9	Style 55		Maximum XI <sup>4</sup>		ZB Max.
								Styles 4, 8 & 9	Style 55	
4.00	1 (std.)	1.750	1.88	3.00	5.06	6.31	0.38	4.69	5.94	8.56
	2	2.500	2.25	3.38	5.44	7.69	0.38	5.06	7.31	8.94
	3	2.000	2.00	3.13	5.19	6.94	0.38	4.81	6.56	8.68
5.00	1 (std.)	2.000	2.00	3.13	5.44	7.19	0.38	5.06	6.81	9.44
	2	3.500	2.25	3.38	5.69	9.06	0.38	5.31	8.69	9.69
	3	2.500	2.25	3.38	5.69	7.94	0.38	5.31	7.56	9.69
	4	3.000	2.25	3.38	5.69	8.31	0.38	5.31	7.94	9.69
6.00	1 (std.)	2.500	2.25	3.50	6.19	8.44	0.50	5.69	7.94	10.93
	2	4.000	2.25	3.50	6.19	9.69	0.50	5.69	9.19	10.93
	3	3.000	2.25	3.50	6.19	8.81	0.50	5.69	8.31	10.93
	4	3.500	2.25	3.50	6.19	9.56	0.50	5.69	9.06	10.93

<sup>3</sup>Dimension XI to be specified by customer. Reference point for rod end Style 55 is end of piston rod.

<sup>4</sup>Dimensions shown are valid for standard WF and WG dimension.

**B**  
 H Series  
 1.50" - 6.00" Bore

**Spherical Bearing Mounting**  
**Style SB**

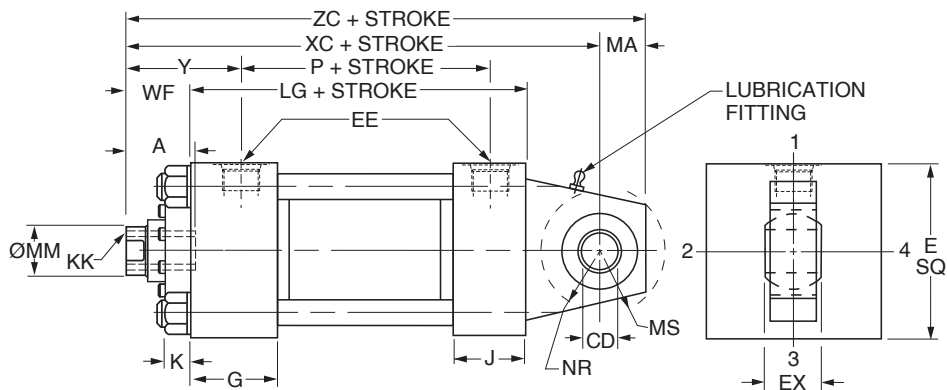
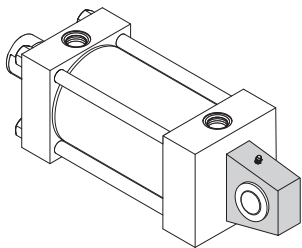

**Style SB – Dimensional and Mounting Data**

Bore Ø	A	CD <sup>1</sup> Ø +0.0000 -0.0005	E	EE		EX	G	J	K Max.	MA	MS	NR	Add Stroke		Maximum Operating psi <sup>2</sup>
				NPTF <sup>4</sup>	SAE <sup>5</sup>								LG	P	
1.50	0.75	0.5000	2.50	1/2	10 <sup>†</sup>	0.44	1.75	1.50	0.42	0.75	0.94	0.63	4.63	2.88	1500
2.00	1.13	0.7500	3.00	1/2	10 <sup>†</sup>	0.66	1.75	1.50	0.57	1.00	1.38	1.00	4.63	2.88	2200
2.50	1.13	0.7500	3.50	1/2	10 <sup>†</sup>	0.66	1.75	1.50	0.57	1.00	1.38	1.00	4.75	3.00	1450
3.25	1.63	1.0000	4.50	3/4	12	0.88	2.00	1.75	0.68	1.25	1.69	1.25	5.50	3.50	1500
4.00	2.00	1.3750	5.00	3/4	12	1.19	2.00	1.75	0.68	1.88	2.44	1.63	5.75	3.75	1850
5.00	2.25	1.7500	6.50	3/4	12	1.53	2.00	1.75	0.94	2.50	2.88	2.06	6.25	4.25	2000
6.00	3.00	2.0000	7.50	1	16	1.75	2.25	2.25	1.05 <sup>3</sup>	2.50	3.31	2.38	7.38	4.88	1800

<sup>1</sup> Diameter CD is hole diameter.

<sup>4</sup>NPTF ports are available at no extra charge.

<sup>2</sup> Maximum operating pressure at 4:1 design factor is based on tensile strength of material.

<sup>5</sup>SAE straight thread ports are standard and are indicated by port number.

Pressure ratings are based on standard bearing ratings.

<sup>†</sup>Previously number 8 SAE in 1.50 thru 2.50 bores now number 10 SAE.

<sup>3</sup> 6.00" bore is constructed with tie rod nuts on both ends.

**Style SB – Recommended maximum swivel angle on each side of the cylinder centerline.**

**Style SB – Dimensional and Mounting Data**

Bore Ø	Rod No.	MM Rod Ø	Thread		WF	Y	Add Stroke		
			Style 9 KK <sup>6</sup>	Style 7 KK <sup>6</sup>			XC	XL	ZC
1.50	1 (std.)	0.625	7/16-20	—	1.00	2.00	6.38	7.25	7.13
	2	1.000	—	7/16-20	1.38	2.38	6.75	7.63	7.50
2.00	1 (std.)	1.000	3/4-16	—	1.38	2.38	7.25	8.50	8.25
	2	1.375	—	3/4-16	1.63	2.63	7.50	8.75	8.50
2.50	1 (std.)	1.000	3/4-16	—	1.38	2.38	7.38	8.63	8.38
	2	1.750	—	3/4-16	1.88	2.88	7.88	9.13	8.88
	3	1.375	—	3/4-16	1.63	2.63	7.63	8.88	8.63
3.25	1 (std.)	1.375	1-14	—	1.63	2.75	8.63	10.50	9.88
	2	2.000	—	1-14	2.00	3.13	9.00	10.88	10.25
	3	1.750	—	1-14	1.88	3.00	8.88	10.75	10.13
4.00	1 (std.)	1.750	1 1/4-12	—	1.88	3.00	9.75	11.88	11.63
	2	2.500	—	1 1/4-12	2.25	3.38	10.13	12.25	12.00
	3	2.000	—	1 1/4-12	2.00	3.13	9.88	12.00	11.75
5.00	1 (std.)	2.000	1 1/2-12	—	2.00	3.13	10.50	13.00	13.00
	2	3.500	—	1 1/2-12	2.25	3.38	10.75	13.25	13.25
	3	2.500	—	1 1/2-12	2.25	3.38	10.75	13.25	13.25
	4	3.000	—	1 1/2-12	2.25	3.38	10.75	13.25	13.25
6.00	1 (std.)	2.500	1 7/8-12	—	2.25	3.50	12.13	14.88	14.63
	2	4.000	—	1 7/8-12	2.25	3.50	12.13	14.88	14.63
	3	3.000	—	1 7/8-12	2.25	3.50	12.13	14.88	14.63
	4	3.500	—	1 7/8-12	2.25	3.50	12.13	14.88	14.63

Bore Ø	Head End Mounted		Cap End Mounted	
	Angle a	Tan. of a	Angle a	Tan. of a
1.50	2.00°	.035	2.00°	.035
2.00	2.50°	.044	4.50°	.079
2.50	2.50°	.044	4.50°	.079
3.25	3.00°	.052	3.00°	.052
4.00	2.50°	.044	3.00°	.052
5.00	3.00°	.052	3.00°	.052
6.00	3.00°	.052	3.00°	.052

Note: Dimension X is the maximum off center mounting of the cylinder. To determine dimension X for various stroke lengths multiply the distance between pivot pin holes by tangent of angle a. For extended position use X = XL + 2X stroke.

**Mounting Information**

**Head End Mounting**

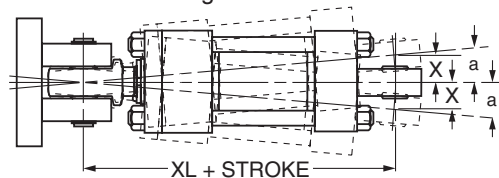

**Cap End Mounting**

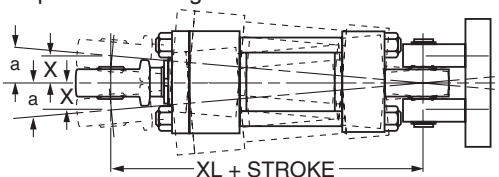

<sup>6</sup> Style 9 and Style 7 threads listed are for a spherical rod eye (sold separately) with pin diameter that matches the cap pin.

1.50" - 6.00" Bore  
**B**  
 H Series

**Spherical Bearing Mounting**  
**Style SE**

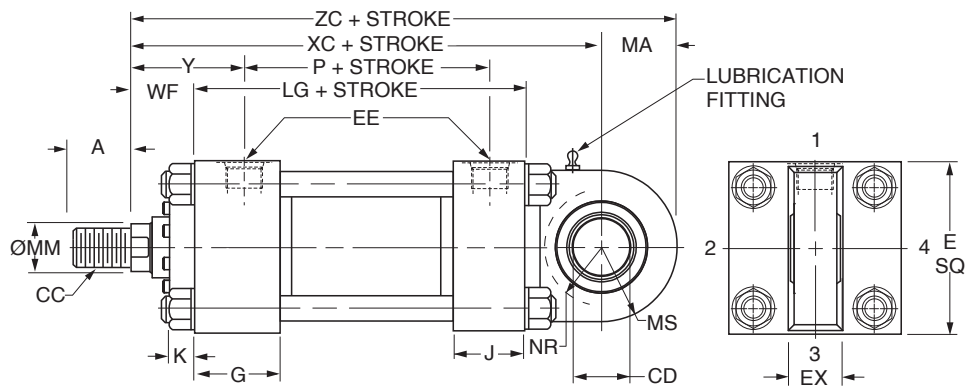
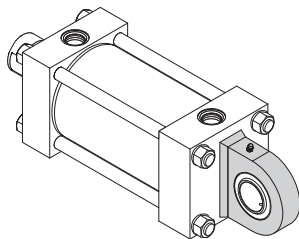

**Style SE – Dimensional and Mounting Data**

Bore Ø	A	CD <sup>1</sup> Ø +0.0000 -0.0005	E	EE		EX	G	J	K Max.	MA	MS	NR	Add Stroke	
				NPTF <sup>3</sup>	SAE <sup>4</sup>								LG	P
1.50	0.75	0.7500	2.50	1/2	10 <sup>†</sup>	0.66	1.75	1.50	0.42	1.00	1.00	0.75	4.63	2.88
2.00	1.13	1.0000	3.00	1/2	10 <sup>†</sup>	0.88	1.75	1.50	0.57	1.25	1.25	1.00	4.63	2.88
2.50	1.13	1.2500	3.50	1/2	10 <sup>†</sup>	1.09	1.75	1.50	0.57	1.50	1.50	1.31	4.75	3.00
3.25	1.63	1.5000	4.50	3/4	12	1.31	2.00	1.75	0.68	2.00	2.00	1.75	5.50	3.50
4.00	2.00	2.0000	5.00	3/4	12	1.75	2.00	1.75	0.68	2.25	2.25	2.13	5.75	3.75
5.00	2.25	2.5000	6.50	3/4	12	2.19	2.00	1.75	0.94	3.00	3.00	2.75	6.25	4.25
6.00	3.00	3.0000	7.50	1	16	2.63	2.25	2.25	1.05	3.50	3.50	3.13	7.38	4.88

<sup>1</sup> Diameter CD is hole diameter.

<sup>†</sup> Previously number 8 SAE in 1.50 thru 2.50 bores now number 10 SAE.

<sup>2</sup> 6.00" bore is constructed with tie rod nuts on both ends.

<sup>3</sup> NPTF ports are available at no extra charge.

<sup>4</sup> SAE straight thread ports are standard and are indicated by port number.

**Style SE – Dimensional and Mounting Data**

Bore Ø	Rod No.	MM Rod Ø	Thread Style 8 CC <sup>5</sup>	A	WF	Y	Add Stroke		
							XC	XL	ZC
1.50	1 (std.)	0.625	1/2-20	0.75	1.00	2.00	6.88	9.01	7.88
	2	1.000	5	5	1.38	2.38	7.25	9.38	8.25
2.00	1 (std.)	1.000	7/8-14	1.13	1.38	2.38	7.56	10.56	8.81
	2	1.375	5	5	1.63	2.63	7.81	10.81	9.06
2.50	1 (std.)	1.000	7/8-14	1.13	1.38	2.38	7.75	10.75	9.25
	2	1.750	5	5	1.88	2.88	8.25	11.25	9.75
	3	1.375	5	5	1.63	2.63	8.00	11.00	9.50
3.25	1 (std.)	1.375	1 1/4-12	1.63	1.63	2.75	9.25	13.38	11.25
	2	2.000	5	5	2.00	3.13	9.63	13.75	11.63
	3	1.750	5	5	1.88	3.00	9.50	13.63	11.50
4.00	1 (std.)	1.750	1 1/2-12	2.00	1.88	3.00	10.13	15.13	12.38
	2	2.500	5	5	2.25	3.38	10.50	15.50	12.75
	3	2.000	5	5	2.00	3.13	10.25	15.25	12.50
5.00	1 (std.)	2.000	1 3/4-12	2.25	2.00	3.13	11.50	17.25	14.50
	2	3.500	5	5	2.25	3.38	11.75	17.50	14.75
	3	2.500	5	5	2.25	3.38	11.75	17.50	14.75
6.00	1 (std.)	2.500	2 1/4-12	3.00	2.25	3.50	13.38	20.38	16.88
	2	4.000	5	5	2.25	3.50	13.38	20.38	16.88
	3	3.000	5	5	2.25	3.50	13.38	20.38	16.88
	4	3.500	5	5	2.25	3.50	13.38	20.38	16.88

<sup>5</sup> To match pin diameter in rod eye and cap, when an oversize rod is required, specify rod end style '3', 'CC' thread and 'A' thread length for the standard rod diameter (Rod No. 1 for the bore), and 'WF' for the oversize rod. Order the rod eye and clevis bracket for the required bore size from the tables on the Style SE Spherical Bearing Accessories page.

**Style SE – Recommended maximum swivel angle on each side of the cylinder centerline.**

Bore Ø	Head End Mounted		Cap End Mounted	
	Angle a	Tan. of a	Angle a	Tan. of a
1.50	2.50°	0.044	3.00°	0.052
2.00	3.00°	0.052	3.00°	0.052
2.50	3.00°	0.052	3.00°	0.052
3.25	3.00°	0.052	2.75°	0.048
4.00	3.00°	0.052	3.00°	0.052
5.00	3.00°	0.052	3.00°	0.052
6.00	3.00°	0.052	3.00°	0.052

Note: Dimension X is the maximum off center mounting of the cylinder. To determine dimension X for various stroke lengths multiply the distance between pivot pin holes by tangent of angle a. For extended position use  $X = XL + 2X$  stroke.

**Mounting Information**

**Head End Mounting**

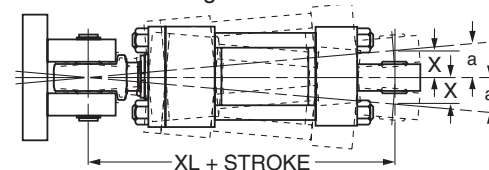

**Cap End Mounting**

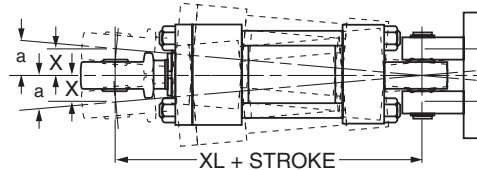



**Double Rod Cylinder  
Style K**

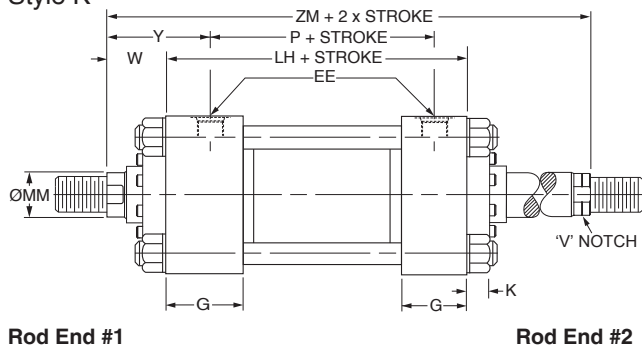

Rod End #1

Rod End #2

**Double Rod End Mounting Styles**

Mounting Styles for Single Rod Models	Mounting Styles for Corresponding Double Rod Models <sup>1</sup>		Dimensions Shown on This Page Supplement Dimensions on 1.50"-6.00" Bore Pages Listed Below
	Load Connected To Rod On Cylinder Mounting End	Load Connected To Rod Opposite Cylinder Mounting End	
T	KT	KT	10
TB	KTB	KTC	10
TD	KTD	KTD	10
J	KJ	KH	11
JB	KJB	KHB	12
JJ	KJJ	KHH	13
C	KC	KC	17
F	KF	KF	18
D	KD	KDB	20
DD	KDD <sup>2</sup>	KDD <sup>2</sup>	22
DE	KDE <sup>2</sup>	KDE <sup>2</sup>	23

<sup>1</sup> Connect load to piston rod without 'V' notch. If only one end of the Double Rod Cylinder is to be cushioned, be sure to clearly specify which end this will be.

<sup>2</sup> Specify XI dimension for Styles DD & DE from #1 rod end (without 'V' notch).

**How to Use Double Rod Cylinder Dimension Drawings**

To determine dimensions for a double rod cylinder, first refer to the desired single rod mounting style cylinder shown on preceding pages of this catalog. (See table above.) After selecting necessary dimensions from that drawing, return to this page supplement the single rod dimensions with those shown on drawing at right and dimension table below. Note that double rod cylinders have a head (Dim. G) at both ends and that dimension LH replaces LG. The double rod dimensions differ from, or are in addition to those for single rod cylinders shown on preceding pages and provide the information needed to completely dimension a double rod cylinder.

On a double rod cylinder where the two rod ends are different, be sure to clearly state which rod end is to be assembled at which end. Port position 1 is standard. If other than standard, specify pos. 2, 3 or 4 when viewed from rod end #1 only.

Bore Ø	Rod No.	MM Rod Ø	Add Stroke			Add 2X Stroke
			LH	SNK	SSK	ZM
1.50	1 (std.)	0.625	4.88	2.88	4.13	6.88
	2	1.000	4.88	2.88	4.13	7.63
2.00	1 (std.)	1.000	4.88	2.88	3.88	7.63
	2	1.375	4.88	2.88	3.88	8.13
2.50	1 (std.)	1.000	5.00	3.00	3.63	7.75
	2	1.750	5.00	3.00	3.63	8.75
	3	1.375	5.00	3.00	3.63	8.25
3.25	1 (std.)	1.375	5.75	3.50	4.38	9.00
	2	2.000	5.75	3.50	4.38	9.75
	3	1.750	5.75	3.50	4.38	9.50
4.00	1 (std.)	1.750	6.00	3.75	4.25	9.75
	2	2.500	6.00	3.75	4.25	10.50
	3	2.000	6.00	3.75	4.25	10.00
5.00	1 (std.)	2.000	6.50	4.25	4.75	10.50
	2	3.500	6.50	4.25	4.75	11.00
	3	2.500	6.50	4.25	4.75	11.00
	4	3.000	6.50	4.25	4.75	11.00
6.00	1 (std.)	2.500	7.38	4.88	5.13	11.88
	2	4.000	7.38	4.88	5.13	11.88
	3	3.000	7.38	4.88	5.13	11.88
	4	3.500	7.38	4.88	5.13	11.88
Replaces On single rod mounting styles:			LG	SN	SS	-
			All Mtg. Styles	F	C	All Mtg. Styles

**Series H Bushing Retention<sup>3</sup>**

B = Bolt -On Bushing with Circular Retainer  
R = Tie Rod Retained Bushing

<sup>3</sup> Bushing retention style may vary when thrust key retainer or bushing drain option is included. Contact factory for details.

**Tie Rod Retained Bushing**

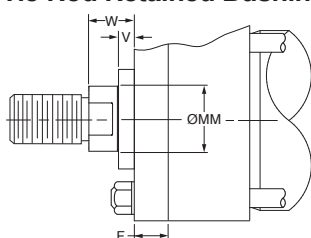

Bore Ø	Rod No.	MM Rod Ø	Mounting Style			
			TC, H, HB, HH, C, F, D, DB, DD, DE, BB, SB, SE	TB, TD	J, JB	JJ
1.50	1 (Std.)	0.625	B	R	R	B
	2	1.000	R	R	R	B
2.00	1 (Std.)	1.000	B	R	R	B
	2	1.375	R	R	R	B
2.50	1 (Std.)	1.000	B	B	B	B
	2	1.750	B	B	R	B
	3	1.375	B	B	B	B
3.25	All	All	B	B	B	B
4.00	All	All	B	B	B	B
5.00	1 (Std.)	2.000	B	B	B	B
	2	3.500	B	B	R	B
	3	2.500	B	B	B	B
	4	3.000	B	B	B	B
6.00	All	All	B	B	B	B

**B**  
 H Series  
 1.50" - 6.00" Bore



**Rod End Dimensions**

**Thread Style 4 (NFPA Style SM)  
Small Male**

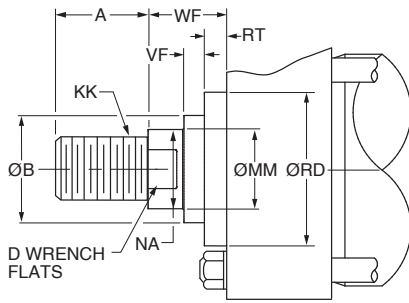

**Thread Style 8 (NFPA Style IM)  
Intermediate Male**

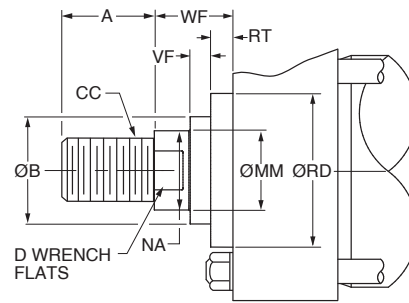

**Thread Style 9<sup>2</sup> (NFPA Style SF)  
Small Female**

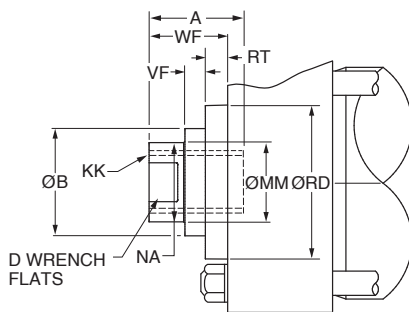

**Thread Style 55<sup>1</sup>**

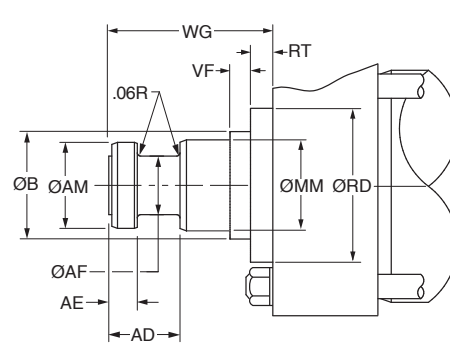

**Rod End Dimensions**

Bore Ø	Rod No.	MM Rod Ø	Thread		Rod Extensions and Pilot Dimensions							
			Style 8 CC	Style 4 & 9 KK	A	B Ø +.000 -0.002	D	NA	VF	RD Ø	RT	WF
7.00	1 (std.)	3.000	2 3/4-12	2 1/4-12	3.50	3.749	2.63	2.88	0.40	5.26	0.85	2.25
	2	5.000	4 3/4-12	3 1/2-12	5.00	5.749	-. <sup>3</sup>	4.88	0.34	7.25	0.91	2.25
	3	3.500	3 1/4-12	2 1/2-12	3.50	4.249	3.00	3.38	0.34	5.76	0.91	2.25
	4	4.000	3 3/4-12	3-12	4.00	4.749	3.38	3.88	0.34	6.31	0.91	2.25
	5	4.500	4 1/4-12	3 1/4-12	4.50	5.249	-. <sup>3</sup>	4.38	0.34	6.94	0.91	2.25
8.00	1 (std.)	3.500	3 1/4-12	2 1/2-12	3.50	4.249	3.00	3.38	0.34	5.76	0.91	2.25
	2	5.500	5 1/4-12	4-12	5.50	6.249	-. <sup>3</sup>	5.38	0.34	7.94	0.91	2.25
	3	4.000	3 3/4-12	3-12	4.00	4.749	3.38	3.88	0.34	6.31	0.91	2.25
	4	4.500	4 1/4-12	3 1/4-12	4.50	5.249	-. <sup>3</sup>	4.38	0.34	6.94	0.91	2.25
	5	5.000	4 3/4-12	3 1/2-12	5.00	5.749	-. <sup>3</sup>	4.88	0.34	7.25	0.91	2.25

**“Special” Thread Style 3**

Special thread, extension, rod eye, blank, etc., are also available.

To order, specify “Style 3” and give desired dimensions for KK, A, W or WF. If otherwise special, furnish dimensioned sketch.

<sup>1</sup> For special WG dimension, specify “Style 3” and give desired dimension for WG. For other changes, place “S” in the model code, and describe rod end with dimensioned sketch.

<sup>2</sup> Style 9 stroke restrictions may apply. See Style 9 Minimum Stroke Table on How to Order page for details.

<sup>3</sup> These piston rod numbers will have 4 spanner wrench holes instead of wrench flats. See rod drawings on 3H Large Bore Piston Rod Ends page for dimensions.

**Style 55 Rod End**

MM Rod Ø	AD	AE +.001 -0.001	AF Ø	AM Ø	WG <sup>1</sup>
3.000	2.44	0.874	2.25	2.95	4.88
3.500	2.69	0.999	2.50	3.45	5.63
4.000	2.69	0.999	3.00	3.95	5.75
4.500	3.19	1.499	3.50	4.45	6.50
5.000	3.19	1.499	3.88	4.95	6.63
5.500	3.94	1.874	4.38	5.45	7.50



**Tie Rods Extended Both Ends**  
**Style TD**  
 (NFA Style MX1)

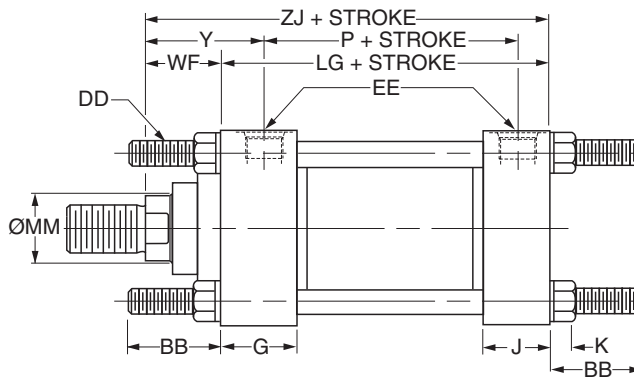
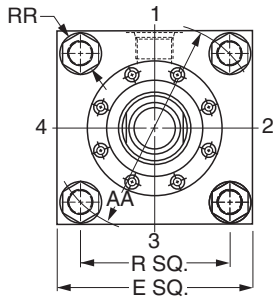
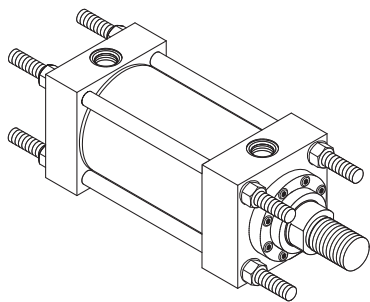

Basic Mounting (T) – NFA MXO – Not shown is no tie rod extended and can be supplied upon request.

**Style TD – Dimensional and Mounting Data**

Bore Ø	Rod No.	MM Rod Ø	AA	BB	DD	E	EE		G	J	K Max.	R	RR	WF	Y	Add Stroke		
							NPTF <sup>1</sup>	SAE <sup>2</sup>								LG	P	ZJ
7.00	1 (std.)	3.000	9.31	4.13	1 1/8-12	8.50	1 1/4	20	2.75	2.75	1.16	6.58	2.00	2.25	3.69	8.50	5.63	10.75
	2	5.000	9.31	4.13	1 1/8-12	8.50	1 1/4	20	2.75	2.75	1.16	6.58	2.00	2.25	3.69	8.50	5.63	10.75
	3	3.500	9.31	4.13	1 1/8-12	8.50	1 1/4	20	2.75	2.75	1.16	6.58	2.00	2.25	3.69	8.50	5.63	10.75
	4	4.000	9.31	4.13	1 1/8-12	8.50	1 1/4	20	2.75	2.75	1.16	6.58	2.00	2.25	3.69	8.50	5.63	10.75
	5	4.500	9.31	4.13	1 1/8-12	8.50	1 1/4	20	2.75	2.75	1.16	6.58	2.00	2.25	3.69	8.50	5.63	10.75
8.00	1 (std.)	3.500	10.61	4.50	1 1/4-12	9.50	1 1/2	24	3.00	3.00	1.28	7.50	2.19	2.25	3.81	9.50	6.38	11.75
	2	5.500	10.61	4.50	1 1/4-12	9.50	1 1/2	24	3.00	3.00	1.28	7.50	2.19	2.25	3.81	9.50	6.38	11.75
	3	4.000	10.61	4.50	1 1/4-12	9.50	1 1/2	24	3.00	3.00	1.28	7.50	2.19	2.25	3.81	9.50	6.38	11.75
	4	4.500	10.61	4.50	1 1/4-12	9.50	1 1/2	24	3.00	3.00	1.28	7.50	2.19	2.25	3.81	9.50	6.38	11.75
	5	5.000	10.61	4.50	1 1/4-12	9.50	1 1/2	24	3.00	3.00	1.28	7.50	2.19	2.25	3.81	9.50	6.38	11.75

<sup>1</sup>NPTF ports are available at no extra charge.

<sup>2</sup>SAE straight thread ports are standard and are indicated by port number.

**Style TB**

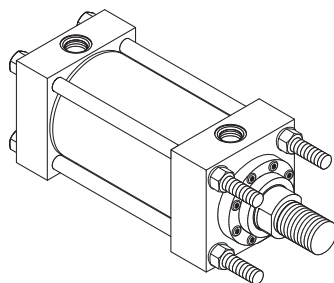

**Style TC**

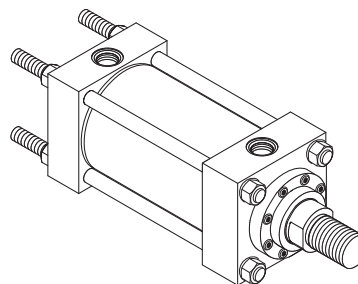

Dimensions for Style TB & TC may be obtained from the above dimensional table.

**B**  
 H Series  
 7.00" & 8.00" Bore

**Head Rectangular Flange Mounting**

Style J  
(NFPA Style MF1)

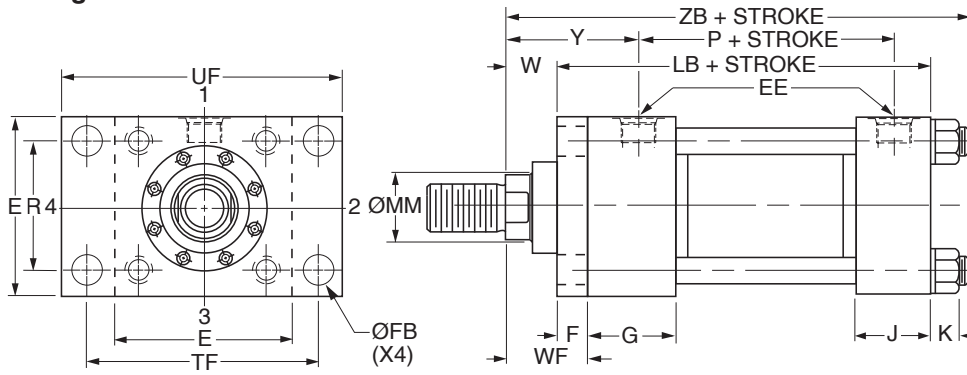
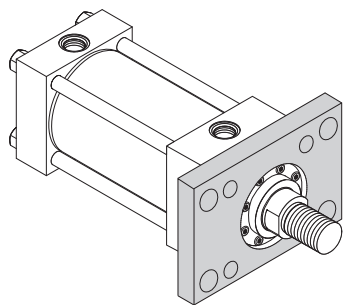

**Style J – Dimensional and Mounting Data**

Bore Ø	Rod No.	MM Rod Ø	E	EE		F	FB Ø	G	J	K Max.	R	TF	UF	W	WF	Y	Add Stroke		
				NPTF <sup>1</sup>	SAE <sup>2</sup>												LB	P	ZB Max.
7.00	1 (std.)	3.000	8.50	1 1/4	20	1.00	1.19	2.75	2.75	1.16	6.58	10.63	12.63	1.25	2.25	3.69	9.50	5.63	12.16
	2	5.000	8.50	1 1/4	20	1.00	1.19	2.75	2.75	1.16	6.58	10.63	12.63	1.25	2.25	3.69	9.50	5.63	12.16
	3	3.500	8.50	1 1/4	20	1.00	1.19	2.75	2.75	1.16	6.58	10.63	12.63	1.25	2.25	3.69	9.50	5.63	12.16
	4	4.000	8.50	1 1/4	20	1.00	1.19	2.75	2.75	1.16	6.58	10.63	12.63	1.25	2.25	3.69	9.50	5.63	12.16
	5	4.500	8.50	1 1/4	20	1.00	1.19	2.75	2.75	1.16	6.58	10.63	12.63	1.25	2.25	3.69	9.50	5.63	12.16
8.00	1 (std.)	3.500	9.50	1 1/2	24	1.00	1.31	3.00	3.00	1.28	7.50	11.81	14.00	1.25	2.25	3.81	10.50	6.38	13.28
	2	5.500	9.50	1 1/2	24	1.00	1.31	3.00	3.00	1.28	7.50	11.81	14.00	1.25	2.25	3.81	10.50	6.38	13.28
	3	4.000	9.50	1 1/2	24	1.00	1.31	3.00	3.00	1.28	7.50	11.81	14.00	1.25	2.25	3.81	10.50	6.38	13.28
	4	4.500	9.50	1 1/2	24	1.00	1.31	3.00	3.00	1.28	7.50	11.81	14.00	1.25	2.25	3.81	10.50	6.38	13.28
	5	5.000	9.50	1 1/2	24	1.00	1.31	3.00	3.00	1.28	7.50	11.81	14.00	1.25	2.25	3.81	10.50	6.38	13.28

<sup>1</sup>NPTF ports are available at no extra charge.

<sup>2</sup>SAE straight thread ports are standard and are indicated by port number.

**Style J – Maximum Operating Pressure**

Bore Ø	Max. psi Push <sup>3</sup>				
	Rod Code				
	1	2	3	4	5
7.00	1000	400	800	400	400
8.00	800	400	700	400	400

<sup>3</sup>Maximum pressure rating – push application.



**Head Square Flange Mounting**  
 Style JB  
 (NFPA Style MF5)

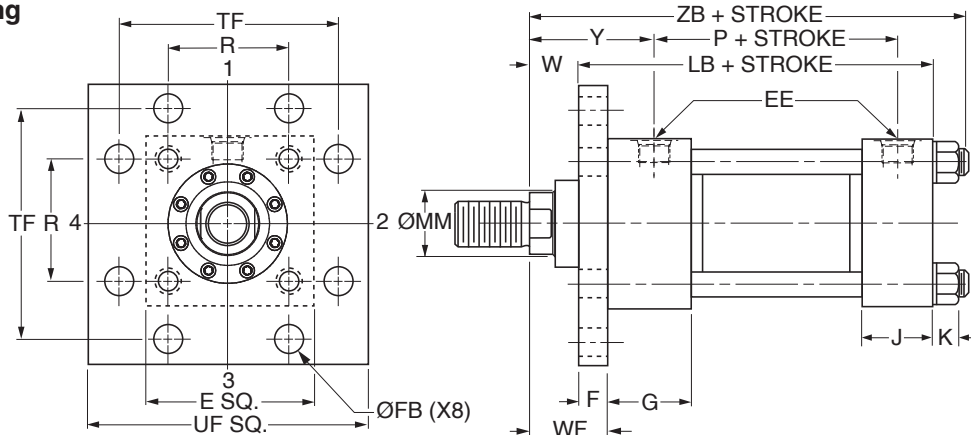
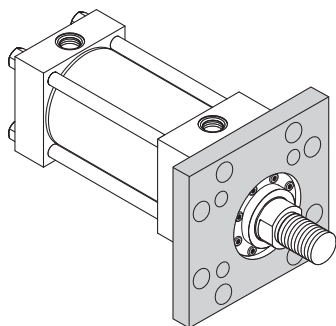

**Style JB – Dimensional and Mounting Data**

Bore Ø	Rod No.	MM Rod Ø	E	EE		F	FB Ø	G	J	K Max.	R	TF	UF	W	WF	Y	Add Stroke		
				NPTF <sup>1</sup>	SAE <sup>2</sup>												LB	P	ZB Max.
7.00	1 (std.)	3.000	8.50	1 1/4	20	1.00	1.19	2.75	2.75	1.16	6.58	10.63	12.63	1.25	2.25	3.69	9.50	5.63	12.16
	2	5.000	8.50	1 1/4	20	1.00	1.19	2.75	2.75	1.16	6.58	10.63	12.63	1.25	2.25	3.69	9.50	5.63	12.16
	3	3.500	8.50	1 1/4	20	1.00	1.19	2.75	2.75	1.16	6.58	10.63	12.63	1.25	2.25	3.69	9.50	5.63	12.16
	4	4.000	8.50	1 1/4	20	1.00	1.19	2.75	2.75	1.16	6.58	10.63	12.63	1.25	2.25	3.69	9.50	5.63	12.16
	5	4.500	8.50	1 1/4	20	1.00	1.19	2.75	2.75	1.16	6.58	10.63	12.63	1.25	2.25	3.69	9.50	5.63	12.16
8.00	1 (std.)	3.500	9.50	1 1/2	24	1.00	1.31	3.00	3.00	1.28	7.50	11.81	14.00	1.25	2.25	3.81	10.50	6.38	13.28
	2	5.500	9.50	1 1/2	24	1.00	1.31	3.00	3.00	1.28	7.50	11.81	14.00	1.25	2.25	3.81	10.50	6.38	13.28
	3	4.000	9.50	1 1/2	24	1.00	1.31	3.00	3.00	1.28	7.50	11.81	14.00	1.25	2.25	3.81	10.50	6.38	13.28
	4	4.500	9.50	1 1/2	24	1.00	1.31	3.00	3.00	1.28	7.50	11.81	14.00	1.25	2.25	3.81	10.50	6.38	13.28
	5	5.000	9.50	1 1/2	24	1.00	1.31	3.00	3.00	1.28	7.50	11.81	14.00	1.25	2.25	3.81	10.50	6.38	13.28

<sup>1</sup>NPTF ports are available at no extra charge.

<sup>2</sup>SAE straight thread ports are standard and are indicated by port number.

**Style JB – Maximum Operating Pressure**

Bore Ø	Max. psi Push <sup>3</sup>				
	Rod Code				
	1	2	3	4	5
7.00	2500	1500	2200	1500	1500
8.00	2000	1400	2000	1400	1400

<sup>3</sup>Maximum pressure rating – push application.

B  
 H Series  
 7.00" & 8.00" Bore

**Head Rectangular Mounting**

Style JJ  
 (NFPA Style ME5)

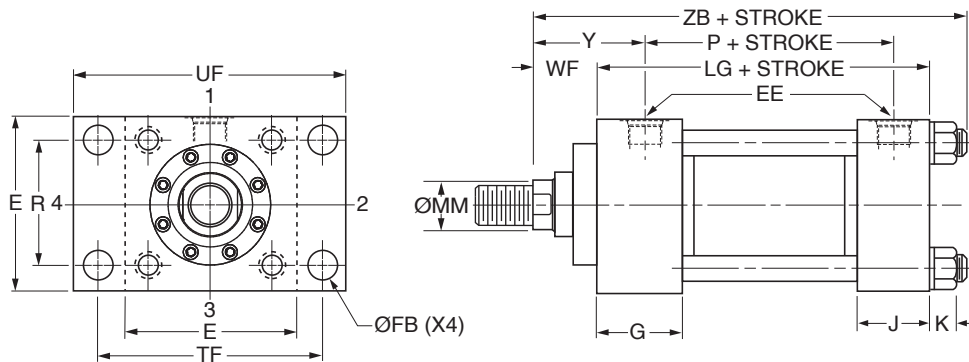
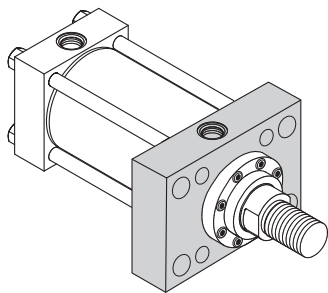

**Style JJ – Dimensional and Mounting Data**

Bore Ø	Rod No.	MM Rod Ø	E	EE		FB Ø	G	J	K Max.	R	TF	UF	WF	Y	Add Stroke		
				NPTF <sup>1</sup>	SAE <sup>2</sup>										LG	P	ZB Max.
7.00	1 (std.)	3.000	8.50	1 1/4	20	1.19	2.75	2.75	1.16	6.58	10.63	12.63	2.25	3.69	8.50	5.63	12.16
	2	5.000	8.50	1 1/4	20	1.19	2.75	2.75	1.16	6.58	10.63	12.63	2.25	3.69	8.50	5.63	12.16
	3	3.500	8.50	1 1/4	20	1.19	2.75	2.75	1.16	6.58	10.63	12.63	2.25	3.69	8.50	5.63	12.16
	4	4.000	8.50	1 1/4	20	1.19	2.75	2.75	1.16	6.58	10.63	12.63	2.25	3.69	8.50	5.63	12.16
	5	4.500	8.50	1 1/4	20	1.19	2.75	2.75	1.16	6.58	10.63	12.63	2.25	3.69	8.50	5.63	12.16
8.00	1 (std.)	3.500	9.50	1 1/2	24	1.31	3.00	3.00	1.28	7.50	11.81	14.00	2.25	3.81	9.50	6.38	13.28
	2	5.500	9.50	1 1/2	24	1.31	3.00	3.00	1.28	7.50	11.81	14.00	2.25	3.81	9.50	6.38	13.28
	3	4.000	9.50	1 1/2	24	1.31	3.00	3.00	1.28	7.50	11.81	14.00	2.25	3.81	9.50	6.38	13.28
	4	4.500	9.50	1 1/2	24	1.31	3.00	3.00	1.28	7.50	11.81	14.00	2.25	3.81	9.50	6.38	13.28
	5	5.000	9.50	1 1/2	24	1.31	3.00	3.00	1.28	7.50	11.81	14.00	2.25	3.81	9.50	6.38	13.28

<sup>1</sup>NPTF ports are available at no extra charge.

<sup>2</sup>SAE straight thread ports are standard and are indicated by port number.



**Cap Rectangular Flange Mounting**  
 Style H  
 (NFA Style MF2)

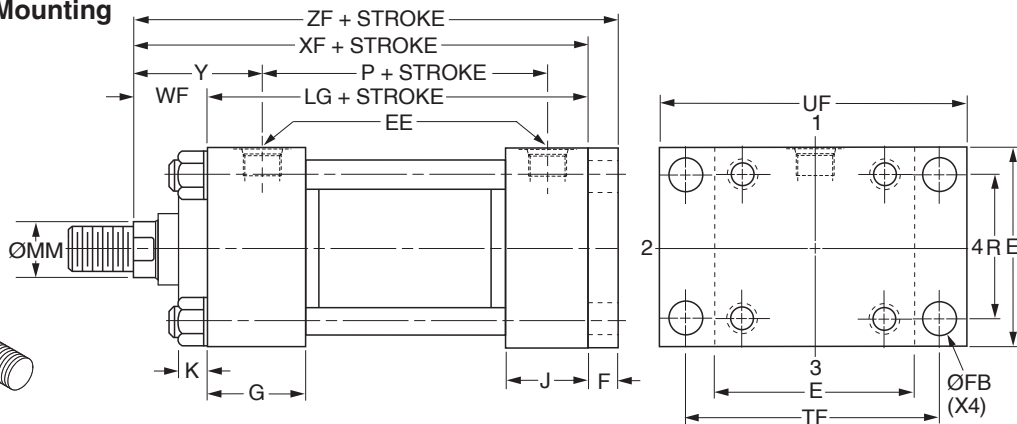
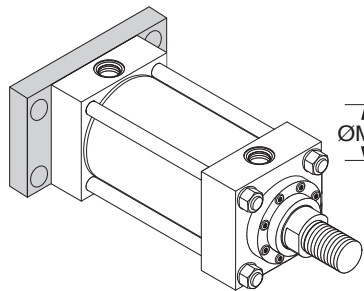

**Style H – Dimensional and Mounting Data**

Bore Ø	Rod No.	MM Rod Ø	E	EE		F	FB Ø	G	J	K Max.	R	TF	UF	WF	Y	Add Stroke			
				NPTF <sup>1</sup>	SAE <sup>2</sup>											LG	P	XF	ZF
7.00	1 (std.)	3.000	8.50	1 1/4	20	1.00	1.19	2.75	2.75	1.16	6.58	10.63	12.63	2.25	3.69	8.50	5.63	10.75	11.75
	2	5.000	8.50	1 1/4	20	1.00	1.19	2.75	2.75	1.16	6.58	10.63	12.63	2.25	3.69	8.50	5.63	10.75	11.75
	3	3.500	8.50	1 1/4	20	1.00	1.19	2.75	2.75	1.16	6.58	10.63	12.63	2.25	3.69	8.50	5.63	10.75	11.75
	4	4.000	8.50	1 1/4	20	1.00	1.19	2.75	2.75	1.16	6.58	10.63	12.63	2.25	3.69	8.50	5.63	10.75	11.75
	5	4.500	8.50	1 1/4	20	1.00	1.19	2.75	2.75	1.16	6.58	10.63	12.63	2.25	3.69	8.50	5.63	10.75	11.75
8.00	1 (std.)	3.500	9.50	1 1/2	24	1.00	1.31	3.00	3.00	1.28	7.50	11.81	14.00	2.25	3.81	9.50	6.38	11.75	12.75
	2	5.500	9.50	1 1/2	24	1.00	1.31	3.00	3.00	1.28	7.50	11.81	14.00	2.25	3.81	9.50	6.38	11.75	12.75
	3	4.000	9.50	1 1/2	24	1.00	1.31	3.00	3.00	1.28	7.50	11.81	14.00	2.25	3.81	9.50	6.38	11.75	12.75
	4	4.500	9.50	1 1/2	24	1.00	1.31	3.00	3.00	1.28	7.50	11.81	14.00	2.25	3.81	9.50	6.38	11.75	12.75
	5	5.000	9.50	1 1/2	24	1.00	1.31	3.00	3.00	1.28	7.50	11.81	14.00	2.25	3.81	9.50	6.38	11.75	12.75

<sup>1</sup>NPTF ports are available at no extra charge.

<sup>2</sup>SAE straight thread ports are standard and are indicated by port number.

**Style H – Maximum Operating Pressure**

Bore Ø	Max. psi Pull <sup>3</sup>				
	Rod Code				
	1	2	3	4	5
7.00	2000	3000	2000	2500	2800
8.00	1700	2500	1700	1800	2200

<sup>3</sup>Maximum pressure rating – pull application.

H Series  
 7.00" & 8.00" Bore  
**B**



**Cap Square Flange Mounting**  
**Style HB**  
 (NFPA Style MF6)

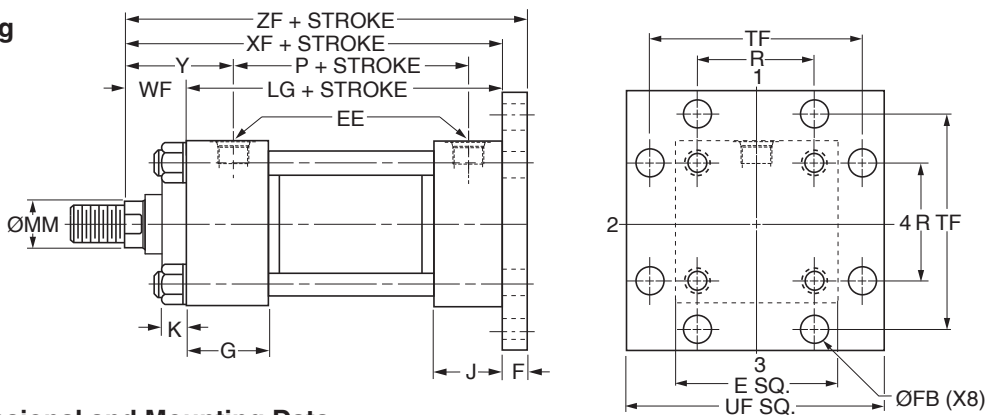
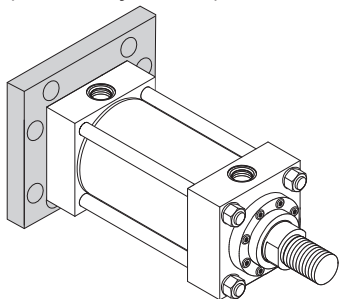

**Style HB (Model 66) – Dimensional and Mounting Data**

Bore Ø	Rod No.	MM Rod Ø	E	EE		F	FB Ø	G	J	K Max.	R	TF	UF	WF	Y	Add Stroke			
				NPTF <sup>1</sup>	SAE <sup>2</sup>											LG	P	XF	ZF
7.00	1 (std.)	3.000	8.50	1 1/4	20	1.00	1.19	2.75	2.75	1.16	6.58	10.63	12.63	2.25	3.69	8.50	5.63	10.75	11.75
	2	5.000	8.50	1 1/4	20	1.00	1.19	2.75	2.75	1.16	6.58	10.63	12.63	2.25	3.69	8.50	5.63	10.75	11.75
	3	3.500	8.50	1 1/4	20	1.00	1.19	2.75	2.75	1.16	6.58	10.63	12.63	2.25	3.69	8.50	5.63	10.75	11.75
	4	4.000	8.50	1 1/4	20	1.00	1.19	2.75	2.75	1.16	6.58	10.63	12.63	2.25	3.69	8.50	5.63	10.75	11.75
	5	4.500	8.50	1 1/4	20	1.00	1.19	2.75	2.75	1.16	6.58	10.63	12.63	2.25	3.69	8.50	5.63	10.75	11.75
8.00	1 (std.)	3.500	9.50	1 1/2	24	1.00	1.31	3.00	3.00	1.28	7.50	11.81	14.00	2.25	3.81	9.50	6.38	11.75	12.75
	2	5.500	9.50	1 1/2	24	1.00	1.31	3.00	3.00	1.28	7.50	11.81	14.00	2.25	3.81	9.50	6.38	11.75	12.75
	3	4.000	9.50	1 1/2	24	1.00	1.31	3.00	3.00	1.28	7.50	11.81	14.00	2.25	3.81	9.50	6.38	11.75	12.75
	4	4.500	9.50	1 1/2	24	1.00	1.31	3.00	3.00	1.28	7.50	11.81	14.00	2.25	3.81	9.50	6.38	11.75	12.75
	5	5.000	9.50	1 1/2	24	1.00	1.31	3.00	3.00	1.28	7.50	11.81	14.00	2.25	3.81	9.50	6.38	11.75	12.75

<sup>1</sup>NPTF ports are available at no extra charge.

<sup>2</sup>SAE straight thread ports are standard and are indicated by port number.

**Cap Rectangular Mounting**  
**Style HH**  
 (NFPA Style ME6)

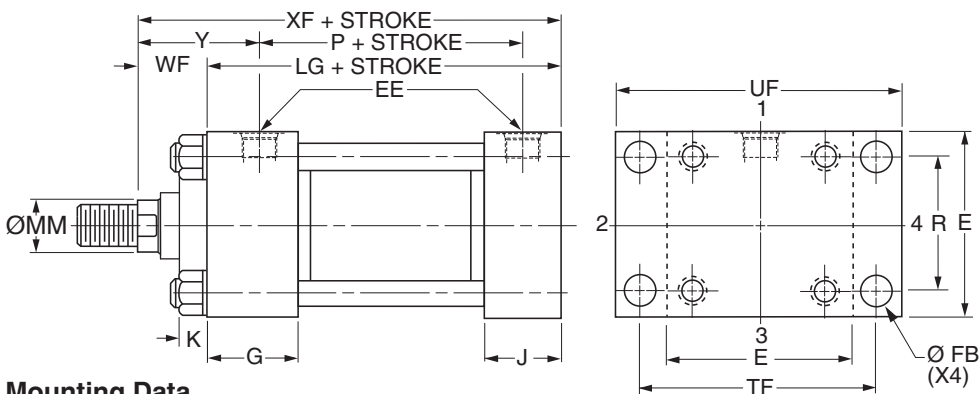
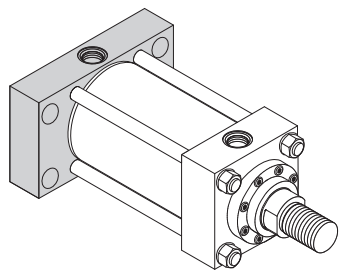

**Style HH – Dimensional and Mounting Data**

Bore Ø	Rod No	MM Rod Ø	E	EE		FB Ø	G	J	K Max.	R	TF	UF	WF	Y	Add Stroke		
				NPTF <sup>1</sup>	SAE <sup>2</sup>										LG	P	XF
7.00	1 (std.)	3.000	8.50	1 1/4	20	1.19	2.75	2.75	1.16	6.58	10.63	12.63	2.25	3.69	8.50	5.63	10.75
	2	5.000	8.50	1 1/4	20	1.19	2.75	2.75	1.16	6.58	10.63	12.63	2.25	3.69	8.50	5.63	10.75
	3	3.500	8.50	1 1/4	20	1.19	2.75	2.75	1.16	6.58	10.63	12.63	2.25	3.69	8.50	5.63	10.75
	4	4.000	8.50	1 1/4	20	1.19	2.75	2.75	1.16	6.58	10.63	12.63	2.25	3.69	8.50	5.63	10.75
	5	4.500	8.50	1 1/4	20	1.19	2.75	2.75	1.16	6.58	10.63	12.63	2.25	3.69	8.50	5.63	10.75
8.00	1 (std.)	3.500	9.50	1 1/2	24	1.31	3.00	3.00	1.28	7.50	11.81	14.00	2.25	3.81	9.50	6.38	11.75
	2	5.500	9.50	1 1/2	24	1.31	3.00	3.00	1.28	7.50	11.81	14.00	2.25	3.81	9.50	6.38	11.75
	3	4.000	9.50	1 1/2	24	1.31	3.00	3.00	1.28	7.50	11.81	14.00	2.25	3.81	9.50	6.38	11.75
	4	4.500	9.50	1 1/2	24	1.31	3.00	3.00	1.28	7.50	11.81	14.00	2.25	3.81	9.50	6.38	11.75
	5	5.000	9.50	1 1/2	24	1.31	3.00	3.00	1.28	7.50	11.81	14.00	2.25	3.81	9.50	6.38	11.75

<sup>1</sup>NPTF ports are available at no extra charge.

<sup>2</sup>SAE straight thread ports are standard and are indicated by port number.



**Side Lug Mounting**  
**Style C**  
(NFPA Style MS2)

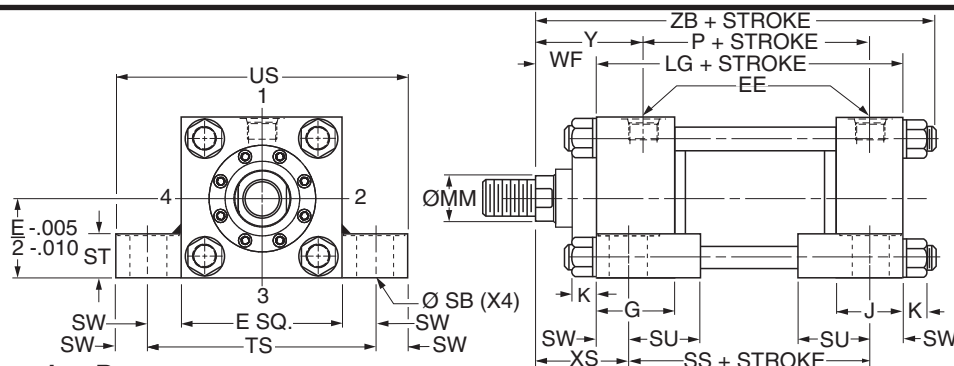
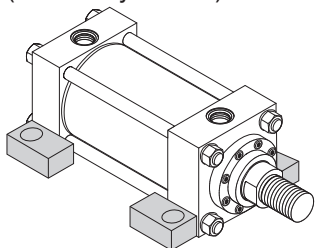

**Style C – Dimensional and Mounting Data**

Bore Ø	Rod No.	MM Rod Ø	E	EE		G	J	K Max.	SB Ø	ST	SU	SW	TS	US	WF	XS	Y	Add Stroke			
				NPTF <sup>1</sup>	SAE <sup>2</sup>													LG	P	SS	ZB Max.
7.00	1 (std.)	3.000	8.50	1 1/4	20	2.75	2.75	1.16	1.56	1.75	2.88	1.38	11.25	14.00	2.25	3.63	3.69	8.50	5.63	5.75	12.16
	2	5.000	8.50	1 1/4	20	2.75	2.75	1.16	1.56	1.75	2.88	1.38	11.25	14.00	2.25	3.63	3.69	8.50	5.63	5.75	12.16
	3	3.500	8.50	1 1/4	20	2.75	2.75	1.16	1.56	1.75	2.88	1.38	11.25	14.00	2.25	3.63	3.69	8.50	5.63	5.75	12.16
	4	4.000	8.50	1 1/4	20	2.75	2.75	1.16	1.56	1.75	2.88	1.38	11.25	14.00	2.25	3.63	3.69	8.50	5.63	5.75	12.16
	5	4.500	8.50	1 1/4	20	2.75	2.75	1.16	1.56	1.75	2.88	1.38	11.25	14.00	2.25	3.63	3.69	8.50	5.63	5.75	12.16
8.00	1 (std.)	3.500	9.50	1 1/2	24	3.00	3.00	1.28	1.56	1.75	2.88	1.38	12.25	15.00	2.25	3.63	3.81	9.50	6.38	6.75	13.28
	2	5.500	9.50	1 1/2	24	3.00	3.00	1.28	1.56	1.75	2.88	1.38	12.25	15.00	2.25	3.63	3.81	9.50	6.38	6.75	13.28
	3	4.000	9.50	1 1/2	24	3.00	3.00	1.28	1.56	1.75	2.88	1.38	12.25	15.00	2.25	3.63	3.81	9.50	6.38	6.75	13.28
	4	4.500	9.50	1 1/2	24	3.00	3.00	1.28	1.56	1.75	2.88	1.38	12.25	15.00	2.25	3.63	3.81	9.50	6.38	6.75	13.28
	5	5.000	9.50	1 1/2	24	3.00	3.00	1.28	1.56	1.75	2.88	1.38	12.25	15.00	2.25	3.63	3.81	9.50	6.38	6.75	13.28

<sup>1</sup>NPTF ports are available at no extra charge.

<sup>2</sup>SAE straight thread ports are standard and are indicated by port number.

**Side Tapped Mounting**  
**Style F**  
(NFPA Style MS4)

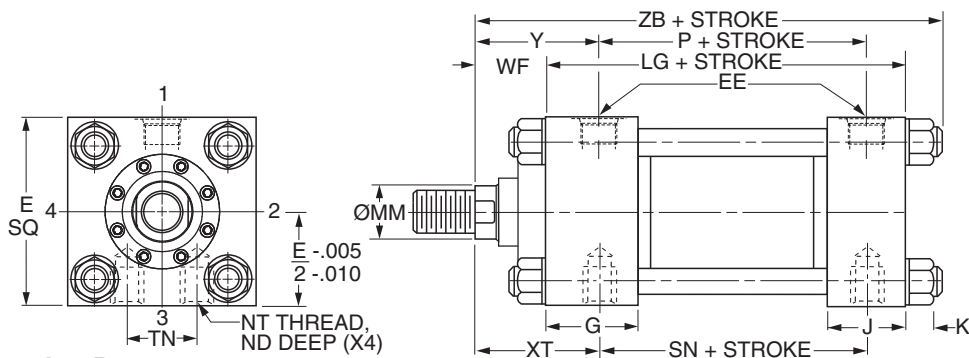
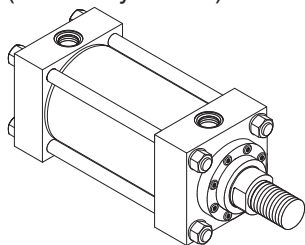

**Style F – Dimensional and Mounting Data**

Bore Ø	Rod No.	MM Rod Ø	E	EE		G	J	K Max.	ND	NT	TN	WF	XT	Y	Add Stroke			
				NPTF <sup>1</sup>	SAE <sup>2</sup>										LG	P	SN	ZB Max.
7.00	1 (std.)	3.000	8.50	1 1/4	20	2.75	2.75	1.16	1.13	1 1/2-6	3.75	2.25	3.81	3.69	8.50	5.63	5.88	12.16
	2	5.000	8.50	1 1/4	20	2.75	2.75	1.16	1.13	1 1/2-6	3.75	2.25	3.81	3.69	8.50	5.63	5.88	12.16
	3	3.500	8.50	1 1/4	20	2.75	2.75	1.16	1.13	1 1/2-6	3.75	2.25	3.81	3.69	8.50	5.63	5.88	12.16
	4	4.000	8.50	1 1/4	20	2.75	2.75	1.16	1.13	1 1/2-6	3.75	2.25	3.81	3.69	8.50	5.63	5.88	12.16
	5	4.500	8.50	1 1/4	20	2.75	2.75	1.16	1.13	1 1/2-6	3.75	2.25	3.81	3.69	8.50	5.63	5.88	12.16
8.00	1 (std.)	3.500	9.50	1 1/2	24	3.00	3.00	1.28	1.50	1 1/2-6	4.25	2.25	3.94	3.81	9.50	6.38	6.63	13.28
	2	5.500	9.50	1 1/2	24	3.00	3.00	1.28	1.50	1 1/2-6	4.25	2.25	3.94	3.81	9.50	6.38	6.63	13.28
	3	4.000	9.50	1 1/2	24	3.00	3.00	1.28	1.50	1 1/2-6	4.25	2.25	3.94	3.81	9.50	6.38	6.63	13.28
	4	4.500	9.50	1 1/2	24	3.00	3.00	1.28	1.50	1 1/2-6	4.25	2.25	3.94	3.81	9.50	6.38	6.63	13.28
	5	5.000	9.50	1 1/2	24	3.00	3.00	1.28	1.50	1 1/2-6	4.25	2.25	3.94	3.81	9.50	6.38	6.63	13.28

<sup>1</sup>NPTF ports are available at no extra charge.

<sup>2</sup>SAE straight thread ports are standard and are indicated by port number.

**B**  
H Series  
7.00" & 8.00" Bore

**Cap Fixed Clevis Mounting**  
**Style BB**  
**(NFPA Style MP1)**

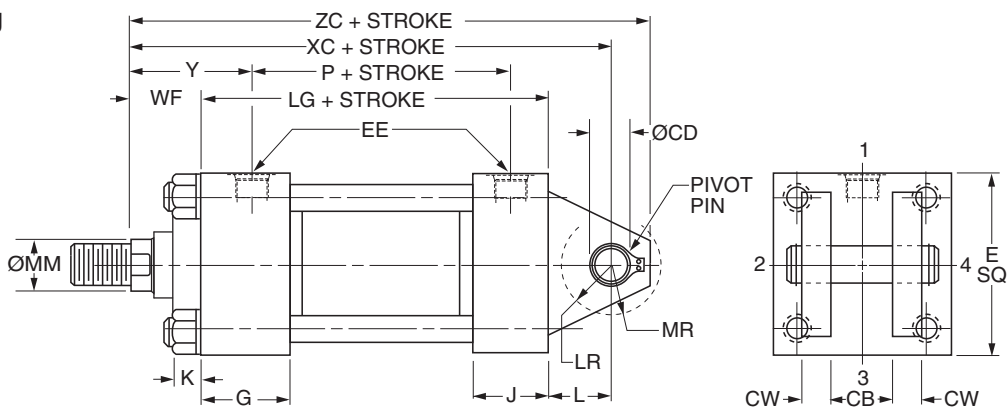
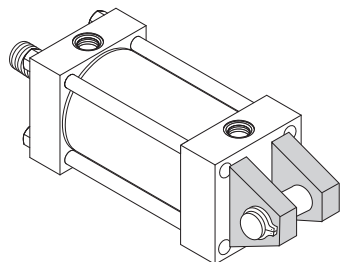

**Style BB – Dimensional and Mounting Data**

Bore Ø	Rod No.	MM Rod Ø	CB	CD <sup>3</sup> Ø +0.000 -0.002	CW	E	EE		G	J	K Max.	L	LR	MR
							NPTF <sup>1</sup>	SAE <sup>2</sup>						
7.00	1 (std.)	3.000	3.00	2.501	1.50	8.50	1 1/4	20	2.75	2.75	1.16	3.00	2.75	2.88
	2	5.000	3.00	2.501	1.50	8.50	1 1/4	20	2.75	2.75	1.16	3.00	2.75	2.88
	3	3.500	3.00	2.501	1.50	8.50	1 1/4	20	2.75	2.75	1.16	3.00	2.75	2.88
	4	4.000	3.00	2.501	1.50	8.50	1 1/4	20	2.75	2.75	1.16	3.00	2.75	2.88
	5	4.500	3.00	2.501	1.50	8.50	1 1/4	20	2.75	2.75	1.16	3.00	2.75	2.88
8.00	1 (std.)	3.500	3.00	3.001	1.50	9.50	1 1/2	24	3.00	3.00	1.28	3.25	3.25	3.13
	2	5.500	3.00	3.001	1.50	9.50	1 1/2	24	3.00	3.00	1.28	3.25	3.25	3.13
	3	4.000	3.00	3.001	1.50	9.50	1 1/2	24	3.00	3.00	1.28	3.25	3.25	3.13
	4	4.500	3.00	3.001	1.50	9.50	1 1/2	24	3.00	3.00	1.28	3.25	3.25	3.13
	5	5.000	3.00	3.001	1.50	9.50	1 1/2	24	3.00	3.00	1.28	3.25	3.25	3.13

<sup>1</sup>NPTF ports are available at no extra charge.

<sup>2</sup>SAE straight thread ports are standard and are indicated by port number.

<sup>3</sup>Diameter CD is pin diameter.

**Style BB – Dimensional and Mounting Data**

Bore Ø	Rod No.	MM Rod Ø	WF	Y	Add Stroke			
					LG	P	XC	ZC
7.00	1 (std.)	3.000	2.25	3.69	8.50	5.63	13.75	16.25
	2	5.000	2.25	3.69	8.50	5.63	13.75	16.25
	3	3.500	2.25	3.69	8.50	5.63	13.75	16.25
	4	4.000	2.25	3.69	8.50	5.63	13.75	16.25
	5	4.500	2.25	3.69	8.50	5.63	13.75	16.25
8.00	1 (std.)	3.500	2.25	3.81	9.50	6.38	15.00	17.75
	2	5.500	2.25	3.81	9.50	6.38	15.00	17.75
	3	4.000	2.25	3.81	9.50	6.38	15.00	17.75
	4	4.500	2.25	3.81	9.50	6.38	15.00	17.75
	5	5.000	2.25	3.81	9.50	6.38	15.00	17.75



**Head Trunnion Mounting**  
**Style D**  
**(NFPA Style MT1)**

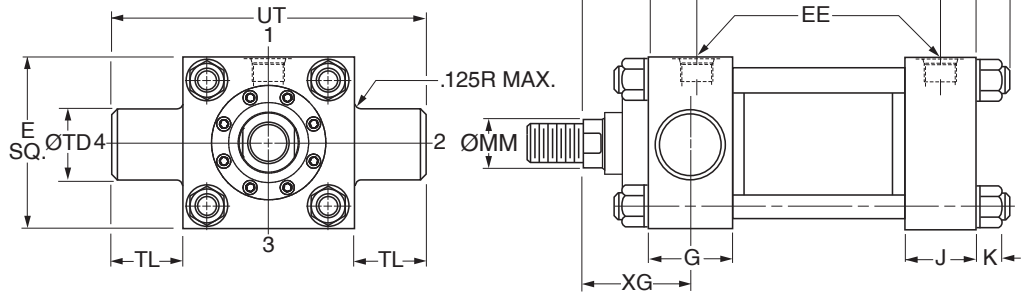
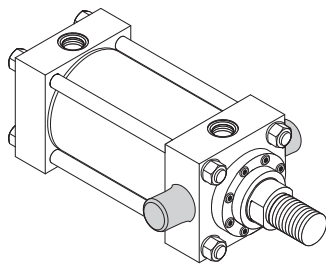

**Style D – Dimensional and Mounting Data**

Bore Ø	Rod No.	MM Rod Ø	E	EE		G	J	K Max.	TD Ø +.000 -.002	TL	UT	WF	Y	XG
				NPTF <sup>1</sup>	SAE <sup>2</sup>									
7.00	1 (std.)	3.000	8.50	1 1/4	20	2.75	2.75	1.16	2.500	2.50	13.50	2.25	3.69	3.63
	2	5.000	8.50	1 1/4	20	2.75	2.75	1.16	2.500	2.50	13.50	2.25	3.69	3.63
	3	3.500	8.50	1 1/4	20	2.75	2.75	1.16	2.500	2.50	13.50	2.25	3.69	3.63
	4	4.000	8.50	1 1/4	20	2.75	2.75	1.16	2.500	2.50	13.50	2.25	3.69	3.63
	5	4.500	8.50	1 1/4	20	2.75	2.75	1.16	2.500	2.50	13.50	2.25	3.69	3.63
8.00	1 (std.)	3.500	9.50	1 1/2	24	3.00	3.00	1.28	3.000	3.00	15.50	2.25	3.81	3.75
	2	5.500	9.50	1 1/2	24	3.00	3.00	1.28	3.000	3.00	15.50	2.25	3.81	3.75
	3	4.000	9.50	1 1/2	24	3.00	3.00	1.28	3.000	3.00	15.50	2.25	3.81	3.75
	4	4.500	9.50	1 1/2	24	3.00	3.00	1.28	3.000	3.00	15.50	2.25	3.81	3.75
	5	5.000	9.50	1 1/2	24	3.00	3.00	1.28	3.000	3.00	15.50	2.25	3.81	3.75

<sup>1</sup>NPTF ports are available at no extra charge.

<sup>2</sup>SAE straight thread ports are standard and are indicated by port number.

**Style D – Dimensional and Mounting Data**

Bore Ø	Rod No.	MM Rod Ø	Add Stroke		
			LG	P	ZB Max.
7.00	1 (std.)	3.000	8.50	5.63	12.16
	2	5.000	8.50	5.63	12.16
	3	3.500	8.50	5.63	12.16
	4	4.000	8.50	5.63	12.16
	5	4.500	8.50	5.63	12.16
8.00	1 (std.)	3.500	9.50	6.38	13.28
	2	5.500	9.50	6.38	13.28
	3	4.000	9.50	6.38	13.28
	4	4.500	9.50	6.38	13.28
	5	5.000	9.50	6.38	13.28

**B**  
 H Series  
 7.00" & 8.00" Bore

**Cap Trunnion Mounting**  
 Style DB  
 (NFPA Style MT2)

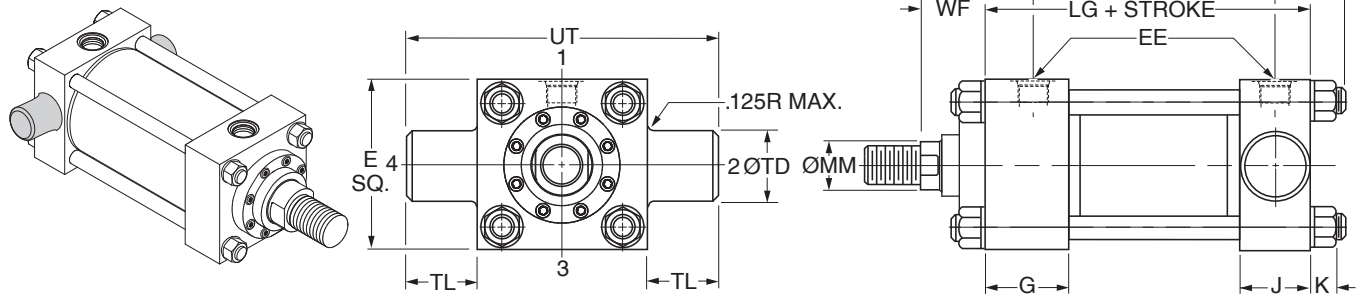

**Style DB – Dimensional and Mounting Data**

Bore Ø	Rod No.	MM Rod Ø	E	EE		G	J	K Max.	TD Ø +.000 -.002	TL	UT	WF	Y
				NPTF <sup>1</sup>	SAE <sup>2</sup>								
7.00	1 (std.)	3.000	8.50	1 1/4	20	2.75	2.75	1.16	2.500	2.50	13.50	2.25	3.69
	2	5.000	8.50	1 1/4	20	2.75	2.75	1.16	2.500	2.50	13.50	2.25	3.69
	3	3.500	8.50	1 1/4	20	2.75	2.75	1.16	2.500	2.50	13.50	2.25	3.69
	4	4.000	8.50	1 1/4	20	2.75	2.75	1.16	2.500	2.50	13.50	2.25	3.69
	5	4.500	8.50	1 1/4	20	2.75	2.75	1.16	2.500	2.50	13.50	2.25	3.69
8.00	1 (std.)	3.500	9.50	1 1/2	24	3.00	3.00	1.28	3.000	3.00	15.50	2.25	3.81
	2	5.500	9.50	1 1/2	24	3.00	3.00	1.28	3.000	3.00	15.50	2.25	3.81
	3	4.000	9.50	1 1/2	24	3.00	3.00	1.28	3.000	3.00	15.50	2.25	3.81
	4	4.500	9.50	1 1/2	24	3.00	3.00	1.28	3.000	3.00	15.50	2.25	3.81
	5	5.000	9.50	1 1/2	24	3.00	3.00	1.28	3.000	3.00	15.50	2.25	3.81

<sup>1</sup>NPTF ports are available at no extra charge.

<sup>2</sup>SAE straight thread ports are standard and are indicated by port number.

**Style DB – Dimensional and Mounting Data**

Bore Ø	Rod No.	MM Rod Ø	Add Stroke			
			LG	P	XJ	ZB Max
7.00	1 (std.)	3.000	8.50	5.63	9.38	12.16
	2	5.000	8.50	5.63	9.38	12.16
	3	3.500	8.50	5.63	9.38	12.16
	4	4.000	8.50	5.63	9.38	12.16
	5	4.500	8.50	5.63	9.38	12.16
8.00	1 (std.)	3.500	9.50	6.38	10.25	13.28
	2	5.500	9.50	6.38	10.25	13.28
	3	4.000	9.50	6.38	10.25	13.28
	4	4.500	9.50	6.38	10.25	13.28
	5	5.000	9.50	6.38	10.25	13.28



**Intermediate Fixed Trunnion Mounting**  
**Style DD**  
(NFPA Former Standard Style MT4)

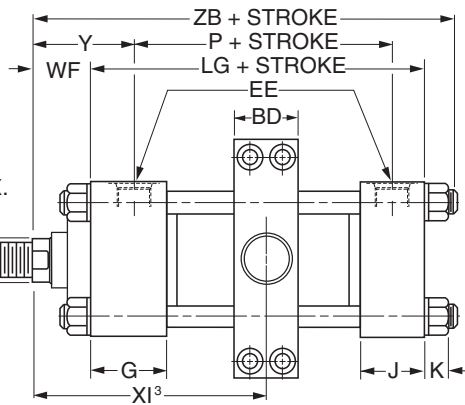
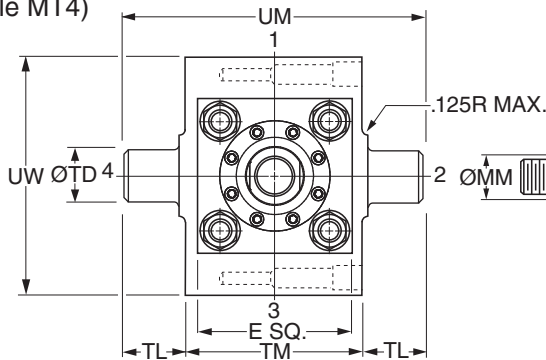
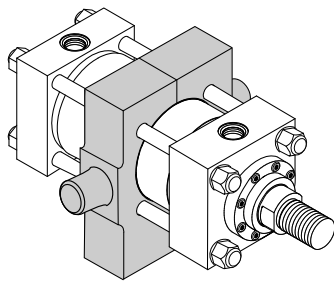

**Style DD – Dimensional and Mounting Data**

Bore Ø	Rod No.	MM Rod Ø	BD	E	EE		G	J	K Max.	TD Ø +.000 -.002	TL	TM	UM	UW	WF	Y
					NPTF <sup>1</sup>	SAE <sup>2</sup>										
7.00	1 (std.)	3.000	3.00	8.50	1 1/4	20	2.75	2.75	1.16	2.500	2.50	9.75	14.75	11.50	2.25	3.69
	2	5.000	3.00	8.50	1 1/4	20	2.75	2.75	1.16	2.500	2.50	9.75	14.75	11.50	2.25	3.69
	3	3.500	3.00	8.50	1 1/4	20	2.75	2.75	1.16	2.500	2.50	9.75	14.75	11.50	2.25	3.69
	4	4.000	3.00	8.50	1 1/4	20	2.75	2.75	1.16	2.500	2.50	9.75	14.75	11.50	2.25	3.69
	5	4.500	3.00	8.50	1 1/4	20	2.75	2.75	1.16	2.500	2.50	9.75	14.75	11.50	2.25	3.69
8.00	1 (std.)	3.500	3.50	9.50	1 1/2	24	3.00	3.00	1.28	3.000	3.00	11.00	17.00	13.38	2.25	3.81
	2	5.500	3.50	9.50	1 1/2	24	3.00	3.00	1.28	3.000	3.00	11.00	17.00	13.38	2.25	3.81
	3	4.000	3.50	9.50	1 1/2	24	3.00	3.00	1.28	3.000	3.00	11.00	17.00	13.38	2.25	3.81
	4	4.500	3.50	9.50	1 1/2	24	3.00	3.00	1.28	3.000	3.00	11.00	17.00	13.38	2.25	3.81
	5	5.000	3.50	9.50	1 1/2	24	3.00	3.00	1.28	3.000	3.00	11.00	17.00	13.38	2.25	3.81

<sup>1</sup>NPTF ports are available at no extra charge.

<sup>2</sup>SAE straight thread ports are standard and are indicated by port number.

**Style DD – Dimensional and Mounting Data**

Bore Ø	Rod No.	MM Rod Ø	Minimum XI <sup>3</sup>		Style DD Minimum Stroke	Add Stroke				
			Styles 4, 8 & 9	Style 55		LG	P	Maximum XI <sup>4</sup>		ZB Max.
								Styles 4, 8 & 9	Style 55	
7.00	1 (std.)	3.000	6.56	9.19	0.13	8.50	5.63	6.44	9.06	12.16
	2	5.000	6.56	10.94	0.13	8.50	5.63	6.44	10.81	12.16
	3	3.500	6.56	9.94	0.13	8.50	5.63	6.44	9.81	12.16
	4	4.000	6.56	10.06	0.13	8.50	5.63	6.44	9.94	12.16
	5	4.500	6.56	10.81	0.13	8.50	5.63	6.44	10.69	12.16
8.00	1 (std.)	3.500	7.06	10.44	0.13	9.50	6.38	6.94	10.31	13.28
	2	5.500	7.06	12.31	0.13	9.50	6.38	6.94	12.19	13.28
	3	4.000	7.06	10.56	0.13	9.50	6.38	6.94	10.44	13.28
	4	4.500	7.06	11.31	0.13	9.50	6.38	6.94	11.19	13.28
	5	5.000	7.06	11.44	0.13	9.50	6.38	6.94	11.31	13.28

<sup>3</sup>Dimension XI to be specified by customer. Reference point for rod end Style 55 is end of piston rod.

<sup>4</sup>Dimensions shown are valid for standard WF and WG dimension.

**B**  
H Series  
7.00" & 8.00" Bore



**Heavy Duty Intermediate Fixed Trunnion Mounting**

Style DE  
 (NFPA Current Standard Style MT4)

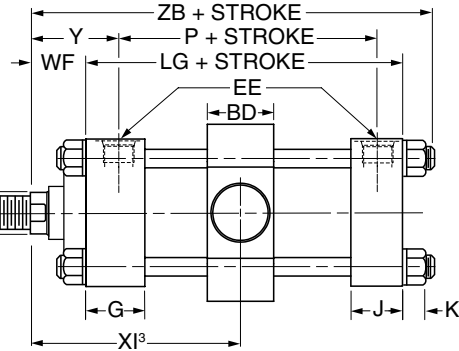
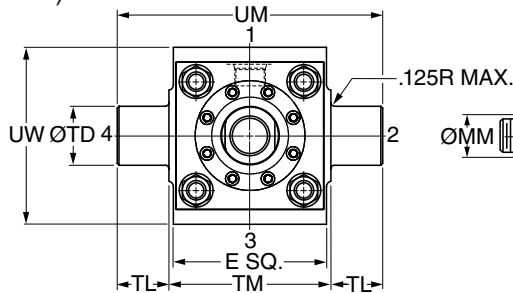
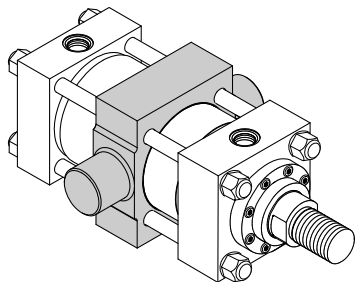

**Style DE – Dimensional and Mounting Data**

Bore Ø	Rod No.	MM Rod Ø	BD	E	EE		G	J	K Max.	TD Ø +.000 -.002	TL	TM	UM	UW	WF	Y
					NPTF <sup>1</sup>	SAE <sup>2</sup>										
7.00	1 (std.)	3.000	4.000	8.50	1 1/4	20	2.75	2.75	1.16	3.500	2.50	9.75	14.75	11.38	2.25	3.69
	2	5.000	4.000	8.50	1 1/4	20	2.75	2.75	1.16	3.500	2.50	9.75	14.75	11.38	2.25	3.69
	3	3.500	4.000	8.50	1 1/4	20	2.75	2.75	1.16	3.500	2.50	9.75	14.75	11.38	2.25	3.69
	4	4.000	4.000	8.50	1 1/4	20	2.75	2.75	1.16	3.500	2.50	9.75	14.75	11.38	2.25	3.69
	5	4.500	4.000	8.50	1 1/4	20	2.75	2.75	1.16	3.500	2.50	9.75	14.75	11.38	2.25	3.69
8.00	1 (std.)	3.500	4.500	9.50	1 1/2	24	3.00	3.00	1.28	4.000	3.00	11.00	17.00	12.00	2.25	3.81
	2	5.500	4.500	9.50	1 1/2	24	3.00	3.00	1.28	4.000	3.00	11.00	17.00	12.00	2.25	3.81
	3	4.000	4.500	9.50	1 1/2	24	3.00	3.00	1.28	4.000	3.00	11.00	17.00	12.00	2.25	3.81
	4	4.500	4.500	9.50	1 1/2	24	3.00	3.00	1.28	4.000	3.00	11.00	17.00	12.00	2.25	3.81
	5	5.000	4.500	9.50	1 1/2	24	3.00	3.00	1.28	4.000	3.00	11.00	17.00	12.00	2.25	3.81

<sup>1</sup>NPTF ports are available at no extra charge.

<sup>2</sup>SAE straight thread ports are standard and are indicated by port number.

**Style DE – Dimensional and Mounting Data**

Bore Ø	Rod No.	MM Rod Ø	Minimum XI <sup>3</sup>		Style DE Minimum Stroke	Add Stroke				
			Styles 4, 8 & 9	Style 55		LG	P	Maximum XI <sup>4</sup>		ZB Max.
								Styles 4, 8 & 9	Style 55	
7.00	1 (std.)	3.000	7.06	9.69	1.13	8.50	5.63	5.94	8.56	12.16
	2	5.000	7.06	11.44	1.13	8.50	5.63	5.94	10.31	12.16
	3	3.500	7.06	10.44	1.13	8.50	5.63	5.94	9.31	12.16
	4	4.000	7.06	10.56	1.13	8.50	5.63	5.94	9.44	12.16
	5	4.500	7.06	11.31	1.13	8.50	5.63	5.94	10.19	12.16
8.00	1 (std.)	3.500	7.56	10.94	1.13	9.50	6.38	6.44	9.81	13.28
	2	5.500	7.56	12.81	1.13	9.50	6.38	6.44	11.69	13.28
	3	4.000	7.56	11.06	1.13	9.50	6.38	6.44	9.94	13.28
	4	4.500	7.56	11.81	1.13	9.50	6.38	6.44	10.69	13.28
	5	5.000	7.56	11.94	1.13	9.50	6.38	6.44	10.81	13.28

<sup>3</sup>Dimension XI to be specified by customer. Reference point for rod end Style 55 is end of piston rod.

<sup>4</sup>Dimensions shown are valid for standard WF and WG dimension.



**Spherical Bearing Mounting**  
 Style SE)

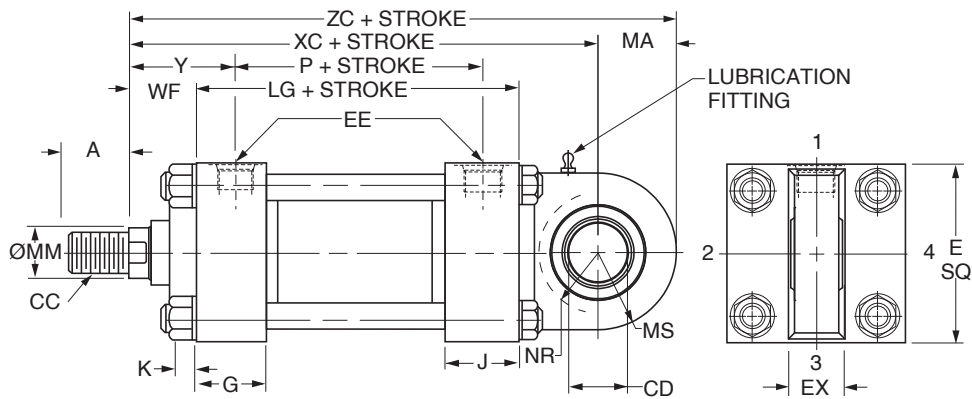
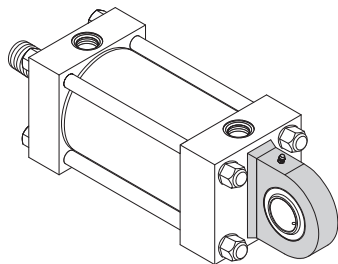

**Style SE — Dimensional and Mounting Data**

Bore Ø	Rod No.	MM Rod Ø	A	CD <sup>3</sup> Ø +0.0000 -0.0005	E	EE		EX	G	J	K Max.	MS	MA	NR	WF	Y
						NPTF <sup>1</sup>	SAE <sup>2</sup>									
7.00	1 (std.)	3.000	3.50	3.5000	8.50	1 1/4	20	3.06	2.75	2.75	1.16	4.00	4.00	3.68	2.25	3.69
	2	5.000	3.50	3.5000	8.50	1 1/4	20	3.06	2.75	2.75	1.16	4.00	4.00	3.68	2.25	3.69
	3	3.500	3.50	3.5000	8.50	1 1/4	20	3.06	2.75	2.75	1.16	4.00	4.00	3.68	2.25	3.69
	4	4.000	3.50	3.5000	8.50	1 1/4	20	3.06	2.75	2.75	1.16	4.00	4.00	3.68	2.25	3.69
	5	4.500	3.50	3.5000	8.50	1 1/4	20	3.06	2.75	2.75	1.16	4.00	4.00	3.68	2.25	3.69
8.00	1 (std.)	3.500	3.50	4.0000	9.50	1 1/2	24	3.50	3.00	3.00	1.28	4.50	4.50	4.13	2.25	3.81
	2	5.500	3.50	4.0000	9.50	1 1/2	24	3.50	3.00	3.00	1.28	4.50	4.50	4.13	2.25	3.81
	3	4.000	3.50	4.0000	9.50	1 1/2	24	3.50	3.00	3.00	1.28	4.50	4.50	4.13	2.25	3.81
	4	4.500	3.50	4.0000	9.50	1 1/2	24	3.50	3.00	3.00	1.28	4.50	4.50	4.13	2.25	3.81
	5	5.000	3.50	4.0000	9.50	1 1/2	24	3.50	3.00	3.00	1.28	4.50	4.50	4.13	2.25	3.81

<sup>1</sup>NPTF ports are available at no extra charge.

<sup>2</sup>SAE straight thread ports are standard and are indicated by port number.

<sup>3</sup>Dimension CD is pin diameter.

**Style SE – Dimensional and Mounting Data**

Bore Ø	Rod No.	MM Rod Ø	Thread Style 8 CC <sup>4</sup>	A	Add Stroke				
					LG	P	XC	XL	ZC
7.00	1 (std.)	3.000	2 3/4-12	3.50	8.50	5.63	15.25	23.25	19.25
	2	5.000	<sup>4</sup>	<sup>4</sup>	8.50	5.63	15.25	23.25	19.25
	3	3.500	<sup>4</sup>	<sup>4</sup>	8.50	5.63	15.25	23.25	19.25
	4	4.000	<sup>4</sup>	<sup>4</sup>	8.50	5.63	15.25	23.25	19.25
	5	4.500	<sup>4</sup>	<sup>4</sup>	8.50	5.63	15.25	23.25	19.25
8.00	1 (std.)	3.500	3 1/4-12	3.50	9.50	6.38	16.75	25.25	21.25
	2	5.500	<sup>4</sup>	<sup>4</sup>	9.50	6.38	16.75	25.25	21.25
	3	4.000	<sup>4</sup>	<sup>4</sup>	9.50	6.38	16.75	25.25	21.25
	4	4.500	<sup>4</sup>	<sup>4</sup>	9.50	6.38	16.75	25.25	21.25
	5	5.000	<sup>4</sup>	<sup>4</sup>	9.50	6.38	16.75	25.25	21.25

<sup>4</sup> To match pin diameter in rod eye and cap, when an oversize rod is required, specify rod end style '3', 'CC' thread and 'A' thread length for the standard rod diameter (Rod No. 1 for the bore), and 'WF' for the oversize rod.

**Style SE – Recommended maximum swivel angle on each side of the cylinder centerline.**

Bore Ø	Head End Mounted		Cap End Mounted	
	Angle a	Tan. of a	Angle a	Tan. of a
7.00	3.00°	0.052	3.00°	0.052
8.00	3.00°	0.052	3.00°	0.052

Note: Dimension X is the maximum off center mounting of the cylinder. To determine dimension X for various stroke lengths multiply the distance between pivot pin holes by tangent of angle a. For extended position use X = XL + 2X stroke.

**Mounting Information**

**Head End Mounting**

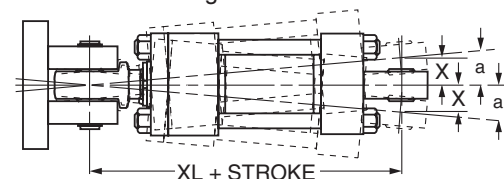

**Cap End Mounting**

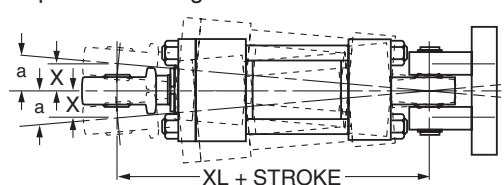

**Double Rod Cylinder**

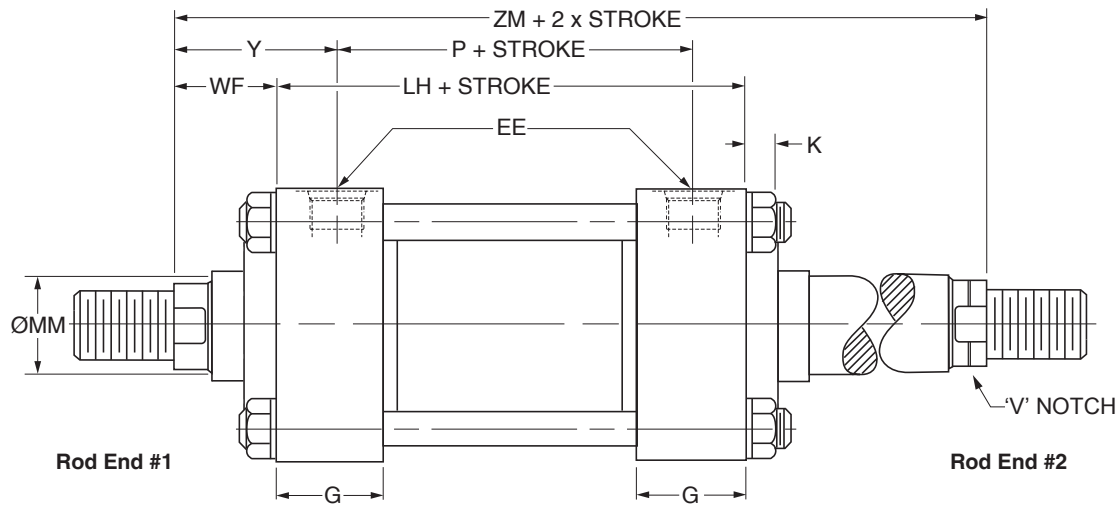

**Double Rod End Mounting Styles**

Mounting Styles for Single Rod Models	Mounting Styles for Corresponding Double Rod Models <sup>1</sup>		Dimensions Shown on This Page Supplement Dimensions on 7.00" - 8.00" Bore Pages Listed Below
	Load Connected To Rod On Cylinder Mounting End	Load Connected To Rod Opposite Cylinder Mounting End	
TB	KTB	KTC	28
TD	KTD	KTD	28
J	KJ	KH	29
JB	KJB	KHB	30
JJ	KJJ	KHH	31
C	KC	KC	34
F	KF	KF	34
D	KD	KDB	36
DD	KDD <sup>2</sup>	KDD <sup>2</sup>	38
DE	KDE <sup>2</sup>	KDE <sup>2</sup>	39

<sup>1</sup> Connect load to piston rod without 'V' notch. If only one end of the Double Rod Cylinder is to be cushioned, be sure to clearly specify which end this will be.

<sup>2</sup> Specify XI dimension for Styles DD & DE from #1 rod end (without 'V' notch).

Bore Ø	Rod No.	MM Rod Ø	WF	Add Stroke			Add 2X Stroke
				LH	SNK	SSK	
7.00	1 (std.)	3.00	2.25	8.50	5.38	5.75	13.00
	2	5.00	2.25	8.50	5.38	5.75	13.00
	3	3.50	2.25	8.50	5.38	5.75	13.00
	4	4.00	2.25	8.50	5.38	5.75	13.00
	5	4.50	2.25	8.50	5.38	5.75	13.00
8.00	1 (std.)	3.50	2.25	9.50	6.13	6.75	14.00
	2	5.50	2.25	9.50	6.13	6.75	14.00
	3	4.00	2.25	9.50	6.13	6.75	14.00
	4	4.50	2.25	9.50	6.13	6.75	14.00
	5	5.00	2.25	9.50	6.13	6.75	14.00
Replaces On single rod mounting styles:				LG	SN	SS	-
				All Mtg. Styles	F	C	All Mtg. Styles

**How to Use Double Rod Cylinder Dimension Drawings**

To determine dimensions for a double rod cylinder, first refer to the desired single rod mounting style cylinder shown on preceding pages of this catalog. (See table above.) After selecting necessary dimensions from that drawing, return to this page supplement the single rod dimensions with those shown on drawing at right and dimension table below. Note that double rod cylinders have a head (Dim. G) at both ends and that dimension LH replaces LG. The double rod dimensions differ from, or are in addition to those for single

rod cylinders shown on preceding pages and provide the information needed to completely dimension a double rod cylinder.

On a double rod cylinder where the two rod ends are different, be sure to clearly state which rod end is to be assembled at which end. Port position 1 is standard. If other than standard, specify pos. 2, 3 or 4 when viewed from rod end #1 only.

## **The large bore, high pressure hydraulic cylinder Atlas designed to meet your needs**

Atlas H Series large bore cylinders provide unmatched reliability, performance, and innovative design features that aid in increasing productivity while reducing operating costs.

Atlas's externally removable bolted bushing assembly makes preventive and routine maintenance quick and easy! In many cases, the cylinder does not have to be removed or disassembled to facilitate service. Our innovative design provides for fast turn around, reduced downtime, and increased productivity.

In addition to our removable bushing assembly, H Series cylinders also include a multitude of innovative design features such as: anti-extrusion body end seals, floating cushions, hi load piston (standard), and various port and rod end options to meet your application requirements.

Every H Series cylinder is individually tested before leaving our plant to assure proper and leak free operation. All H Series cylinders come with an eighteen month warranty standard.

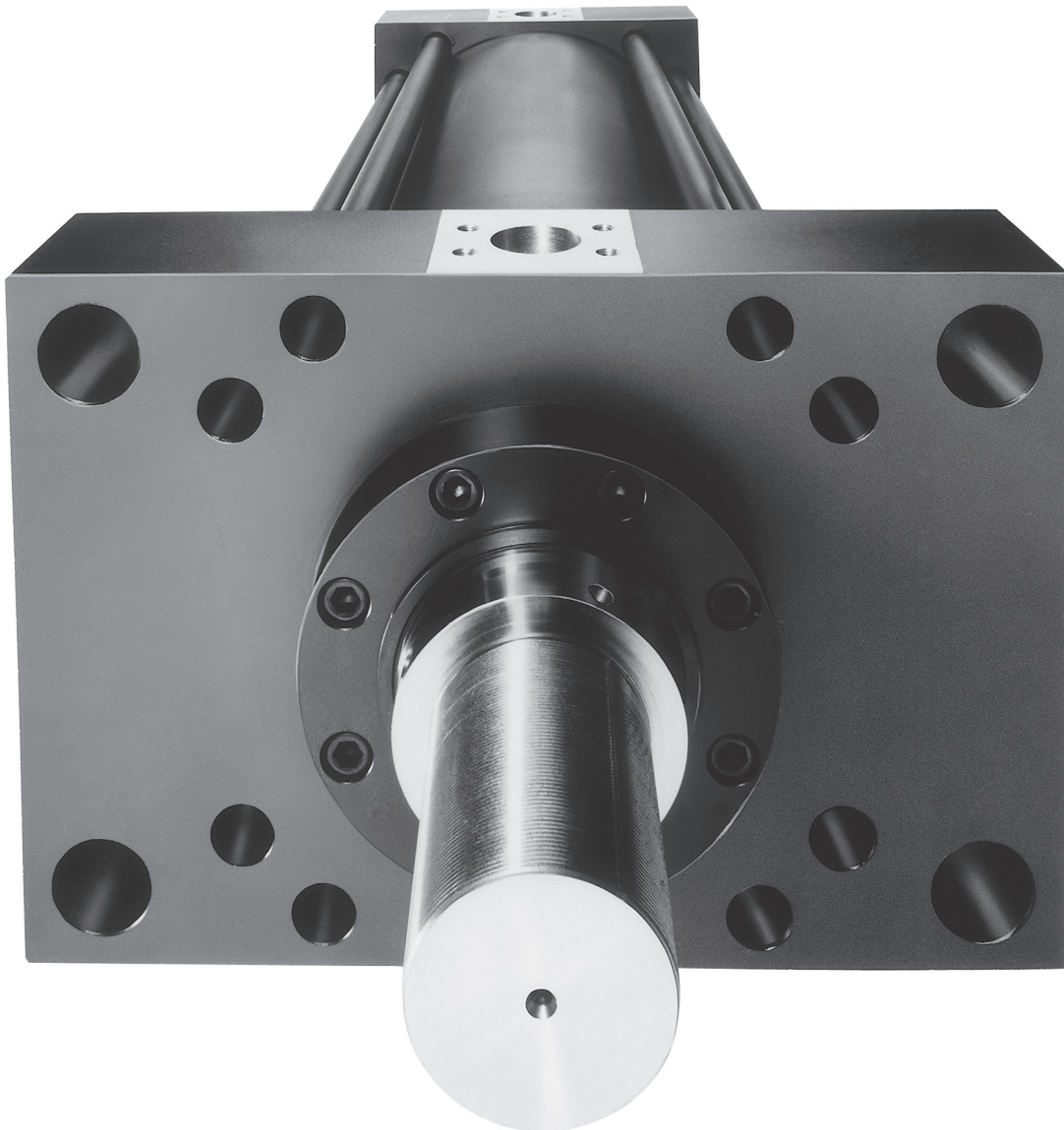

H Series  
10.00" - 20.00" Bore



# These innovative design features make Atlas H Series your best choice... for all your large bore heavy duty hydraulic cylinder applications.

**Primary Seal** – High-performance urethane design combines ease of installation with rugged construction. The ultimate seal in extra heavy duty applications. Completely self-compensating and self-relieving to withstand pressure variations and conform to mechanical deflection that may occur.

**Piston Rod** – Hard chrome-plated and polished for maximum seal and rod bearing life. Two standard thread styles. Rod end is supplied with spanner wrench holes.

**Align-A-Groove** – A  $\frac{3}{16}$ " wide surface machined at each end of the cylinder body. Makes precise mounting quick and easy.

**Rod Bushing** – Standard Composite Load Bearing Bushing offers superior performance in comparison to metal and nylon filled alternatives.

**The Cylinder Body** – Heavy-wall steel tubing is honed to a micro finish bore, providing a wear surface for long lasting piston bearing and seal life.

**Piston Seals** – Problem solving piston seal options.

**Ports** – SAE O-ring straight thread ports are standard.

**Secondary Seal** – Double-Service Wiperseal™ – wipes clean any oil film adhering to the rod on the extend stroke and cleans the rod on the return stroke.

**Bolted Bushing Assembly** – Externally removable without cylinder disassembly. Long composite bearing surface is inboard of the seals, assuring positive lubrication from within the cylinder. An "O" ring is used as a seal between bushing and head.

**Adjustable Floating Stepped Cushions** – For maximum performance. Economical and flexible for even the most demanding applications. Provides superior performance in reducing shock. Cushions are optional and can be supplied at head end, cap end, or both ends without change in envelope or mounting dimensions.

**End Seals** – Pressure-actuated cylinder body-to-head and cap "O" rings (urethane 10.00" - 14.00") and back-up washers.

**Steel Cap** – Bored and grooved to provide concentricity for mating parts.

**Alloy Steel Tie Rod Nuts** – With hardened washer.

**Steel Head** – Bored and grooved to provide concentricity for mating parts.

**High Strength Tie Rods** – Made from 100,000 PSI minimum yield steel with rolled threads for added strength.

**One-Piece Nodular Iron Piston** – The wide piston surface contacting cylinder bore reduces bearing loads. One piece design is piloted to piston rod assuring concentricity. Piston is locked with set screw. Anaerobic adhesive and peening of set screw locks and seals piston to rod.

**H Model Code**

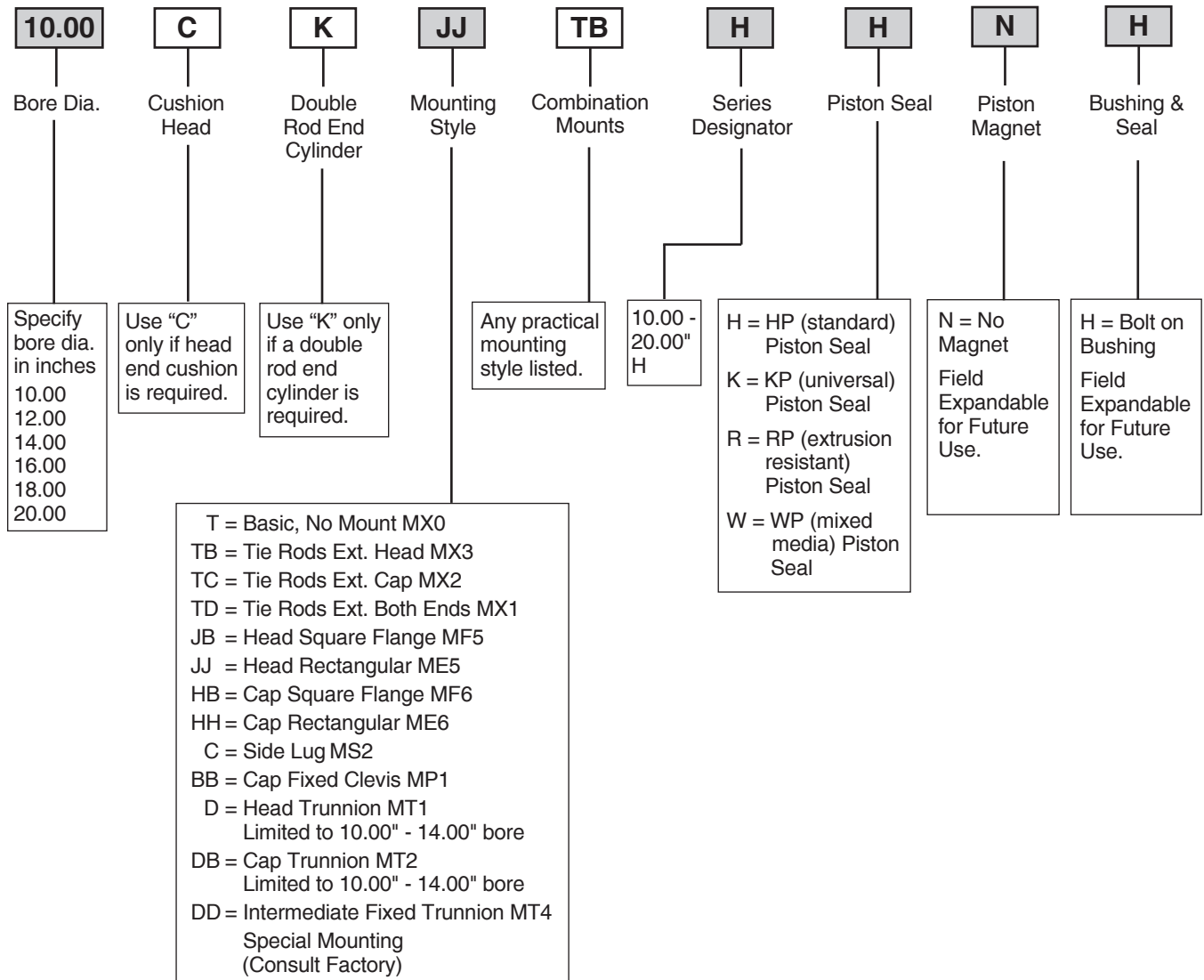

10.00" - 20.00" Bore  
H Series  
G

Shaded boxes identify required model number fields.



**H Model Code**

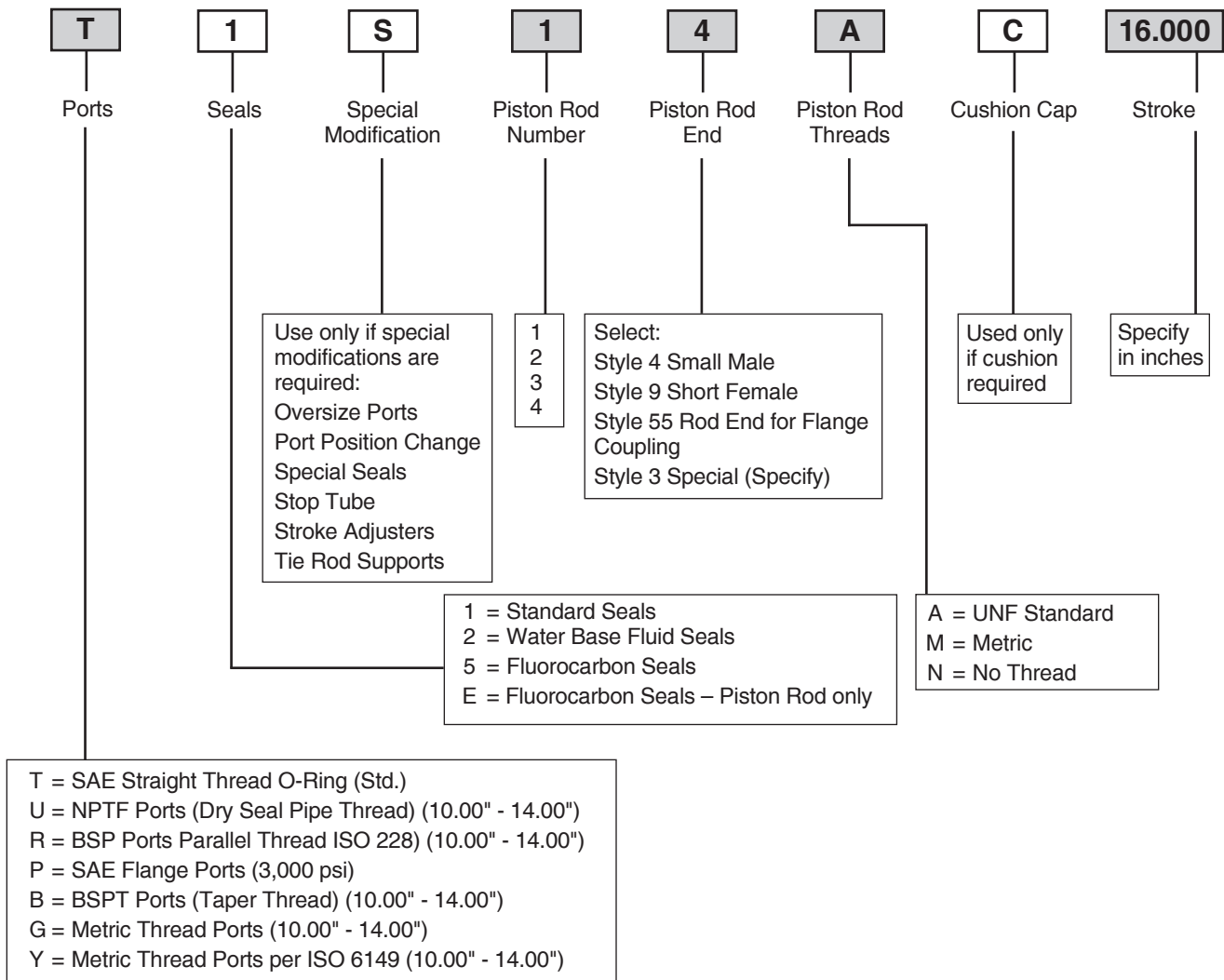

**Style 9 Minimum Stroke Table**

Bore Ø	Rod Ø	Minimum Stroke
10.00	4.500	1.125
	5.000	1.375
	5.500	2.000
	7.000	3.125
12.00	5.500	1.250
	7.000	2.375
	8.000	3.125
14.00	7.000	2.000
	8.000	2.750
	10.000	4.250

Bore Ø	Rod Ø	Minimum Stroke
16.00	8.000	1.750
	9.000	2.500
	10.000	3.250
18.00	9.000	1.500
	10.000	2.250
20.00	10.000	1.250

Shaded boxes identify required model number fields.

**Piston Seal Selection**

Atlas Piston Seal options HP, KP, RP and WP are available in a number of different Seal Classes. Because the Atlas Model Number includes Seal Class but does not include a code for piston seal style, a default piston seal style is designated for each seal class. In the table below rows list each seal class and columns list each piston style. Available piston styles for each

seal class are identified with an 'X' and the default piston seal style is in the shaded cell. To specify an available piston seal style that is not standard, place an 'S' in the Special Modification field of the model number and specify the required piston seal style with text.

Seal Class	Piston Seal Options (Shaded cell is default standard)			
	HP	KP	RP	WP
Class 1 - Polyurethane & Nitrile	X	X	X	X
Class 2 - Nitrile	N/A	X	X	X
Class 5 - Fluorocarbon	N/A	X	X	X
Class 5 Rod Bushing Seals Only	N/A	X	X	X

10.00" - 20.00" Bore  
 H Series  

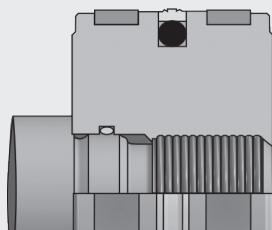

**One Common Piston for 4 Seal Styles**

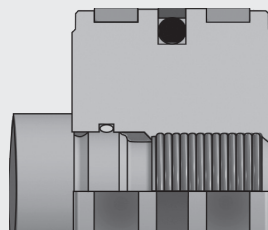

**Standard HP** style with polyurethane piston seal – excellent for most cycling and load holding applications.

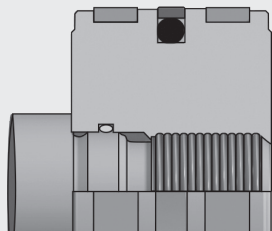

**Optional RP** style with thermoplastic piston seal – superior extrusion resistance to extreme pressure spikes with drift-free performance.



**Optional KP** style with filled PTFE piston seal – low friction, high heat resistance for cycling and load holding service.

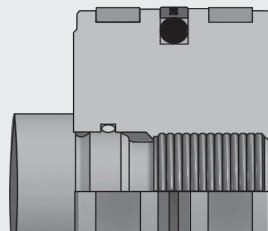

**Optional WP** style mixed media piston seal – low friction primary seal with redundant elastomer delivers superior performance with dissimilar media on either side of the piston.

# H Series Large Bore Composite Bushing

Innovative Solutions from  
Atlas Cylinders

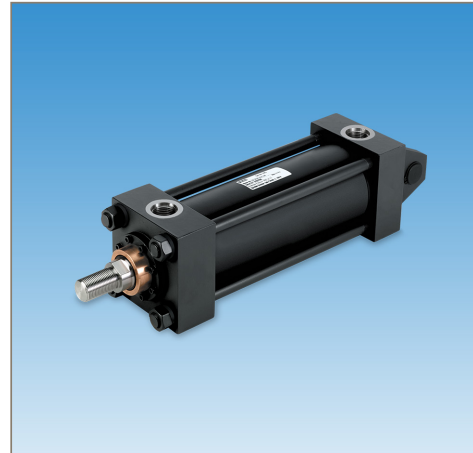

## Customer Value Proposition:

The Atlas Cylinders H Series Large Bore Composite Bushing installed inboard of the primary rod sealing package offers significant performance improvements in comparison to Metal or Filled Nylon Rod Bushings



## Contact Information:

Atlas Cylinders  
**Cylinder Division**  
500 S. Wolf Rd.  
Des Plaines, IL 60016  
www.atlas-cylinders.com

phone 847 298 2400  
fax 800 892 1008

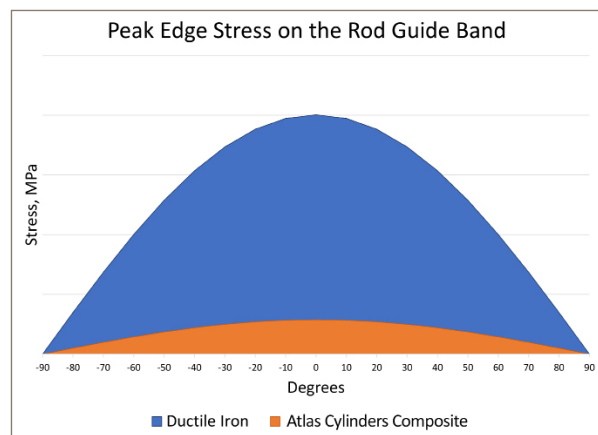

### Key Takeaway:

Contact stress is reduced when any side load force is distributed over a greater area. See how Atlas Cylinders' composite bearing performs over Ductile Iron.

## Product Features:

### Atlas' Composite Versus Metal Bushings

- Better ability to conform to bending deflections resulting in lower peak stresses
- Non-corrosive
- Self lubricating with lower friction
- Ideal for High Water Content fluids

### Atlas' Composite Versus Filled Nylon Bushings

- Higher strength
- Very low water absorption
- Wider temperature range

C  
H Series  
10.00" - 20.00" Bore

**Standard Specifications**

- Heavy Duty Service
- Standard Construction – Square Head – Tie Rod Design
- Nominal Pressure – 3000 psi<sup>1</sup>
- Standard Fluid – Hydraulic Oil
- Standard Temperature – -10°F to +165°F
- Bore Sizes – 10.00" through 20.00"
- Piston Rod Diameter – 4.500" through 10.000"

- Mounting Styles – 12 standard styles at various application ratings
- Strokes – Available in any practical stroke length
- Cushions – Optional at either end or both ends of stroke
- Rod Ends – Three Standard Choices – Specials to Order

<sup>1</sup> If hydraulic operating pressure exceeds 3000 psi, send application data for engineering evaluation and recommendation.

*In line with our policy of continuing product improvement, specifications in this catalog are subject to change.*

**Available Mounting Styles**

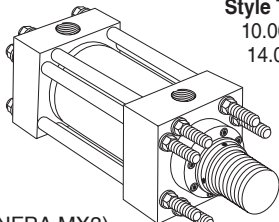
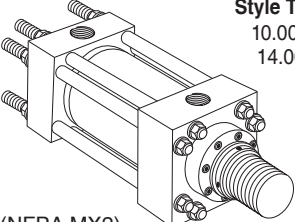
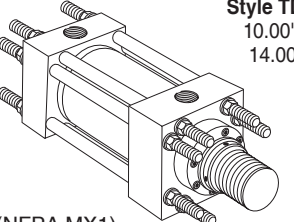
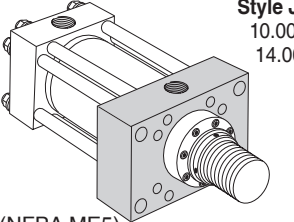
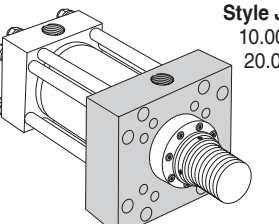
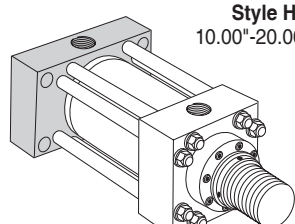
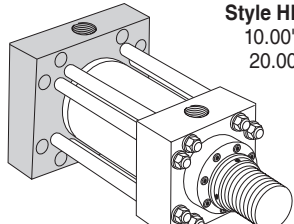
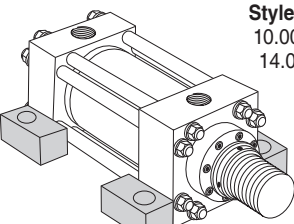
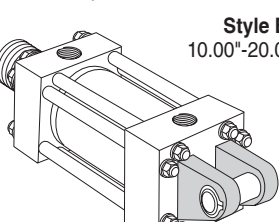
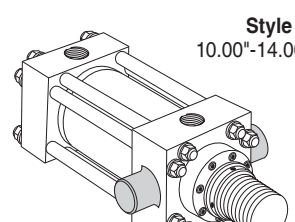
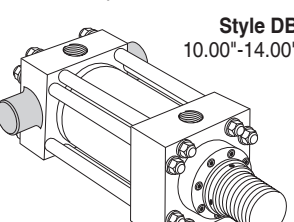
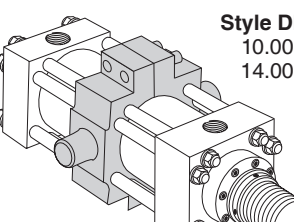
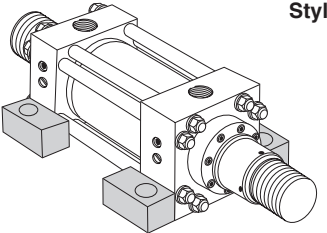
<p>Tie Rods Extended Head End</p>  <p><b>Style TB</b> 10.00"-14.00"</p> <p>(NFPA MX3)</p>	<p>Tie Rods Extended Cap End</p>  <p><b>Style TC</b> 10.00"-14.00"</p> <p>(NFPA MX2)</p>	<p>Tie Rods Extended Both Ends</p>  <p><b>Style TD</b> 10.00"-14.00"</p> <p>(NFPA MX1)</p>	<p>Head Rectangular</p>  <p><b>Style JJ</b> 10.00"-14.00"</p> <p>(NFPA ME5)</p>
<p>Head Square Flange</p>  <p><b>Style JB</b> 10.00"-20.00"</p> <p>(NFPA MF5)</p>	<p>Cap Rectangular</p>  <p><b>Style HH</b> 10.00"-20.00"</p> <p>(NFPA ME6)</p>	<p>Cap Square Flange</p>  <p><b>Style HB</b> 10.00"-20.00"</p> <p>(NFPA MF6)</p>	<p>Side Lug</p>  <p><b>Style C</b> 10.00"-14.00"</p> <p>(NFPA MS2)</p>
<p>Cap Fixed Clevis</p>  <p><b>Style BB</b> 10.00"-20.00"</p> <p>(NFPA MP1)</p>	<p>Head Trunnion</p>  <p><b>Style D</b> 10.00"-14.00"</p> <p>(NFPA MT1)</p>	<p>Cap Trunnion</p>  <p><b>Style DB</b> 10.00"-14.00"</p> <p>(NFPA MT2)</p>	<p>Intermediate Fixed Trunnion</p>  <p><b>Style DD</b> 10.00"-14.00"<sup>3</sup></p> <p>(NFPA MT4)</p>
<p>Double Rod Cylinders</p>  <p><b>Style KC Shown</b></p> <p>Most of the above illustrated mounting styles are available in double rod cylinders.</p>			<p><sup>3</sup> Consult factory for 16.00"-20.00"</p>

10.00" - 20.00" Bore  
 H Series  

**Rod End Dimensions – 10.00" - 20.00" Bore**

**Thread Style 4 (NFPA Style SM)  
Small Male**

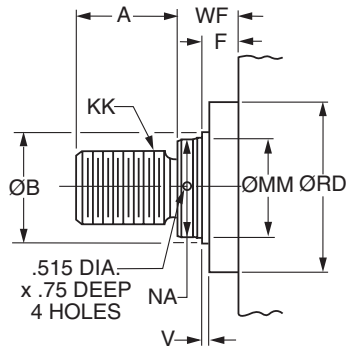

**Thread Style 55<sup>1</sup>  
Flanged Rod End**

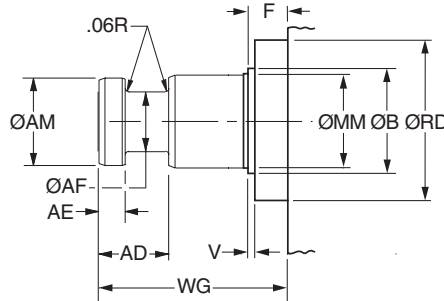

**Thread Style 9<sup>2</sup> (NFPA Style SF)  
Small Female**

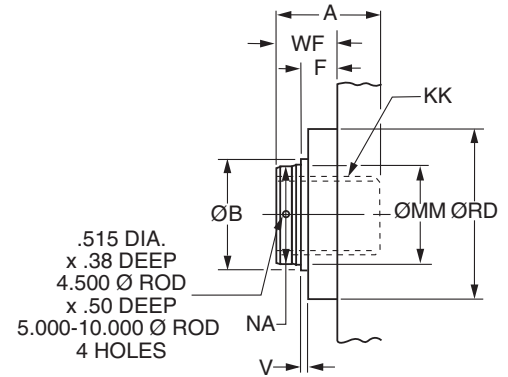

**Rod End Dimensions – 10.00" - 20.00" Bore**

Bore Ø	Rod No.	MM Rod Ø	Thread Style 4 & 9 KK	Rod Extensions and Pilot Dimensions						
				A	B Ø +.000 - .005	F	NA	RD -.005	V	WF
10.00	1 (std.)	4.500	3 1/4-12	4.50	5.249	1.94	4.38	8.249	0.25	2.94
	2	7.000	5-12	7.00	7.999	1.94	6.88	10.499	0.38	3.50
	3	5.000	3 1/2-12	5.00	5.749	1.94	4.88	8.874	0.25	3.19
	4	5.500	4-12	5.50	6.249	1.94	5.38	9.374	0.25	3.19
12.00	1 (std.)	5.500	4-12	5.50	6.249	1.94	5.38	9.374	0.25	3.19
	2	8.000	5 3/4-12	8.00	8.999	1.94	7.88	12.499	0.38	4.00
	3	7.000	5-12	7.00	7.999	1.94	6.88	10.499	0.38	3.50
14.00	1 (std.)	7.000	5-12	7.00	7.999	1.94	6.88	10.499	0.38	3.50
	2	10.000	7 1/4-12	10.00	10.999	1.94	9.88	14.499	0.38	4.50
	3	8.000	5 3/4-12	8.00	8.999	1.94	7.88	12.499	0.38	4.00
16.00	1	8.000	5 3/4-12	8.00	8.999	1.94	7.88	12.499	0.38	4.00
	3	9.000	6 1/2-12	9.00	9.999	1.94	8.88	13.499	0.38	4.25
	4	10.000	7 1/4-12	10.00	10.999	1.94	9.88	14.499	0.38	4.50
18.00	1	9.000	6 1/2-12	9.00	9.999	1.94	8.88	13.499	0.38	4.25
	3	10.000	7 1/4-12	10.00	10.999	1.94	9.88	14.499	0.38	4.50
20.00	1	10.000	7 1/4-12	10.00	10.999	1.94	9.88	14.499	0.38	4.50

**“Special” Thread Style 3**

Special thread, extension, rod eye, blank, etc., are also available.

To order, specify “Style 3” and give desired dimensions for KK, A & WF. If otherwise special, furnish dimensioned sketch.

<sup>1</sup> For special WG dimension, specify “Style 3” and give desired dimension for WG. For other changes, place “S” in the model code, and describe rod end with dimensioned sketch.

<sup>2</sup> Style 9 stroke restrictions may apply. See Style 9 Minimum Stroke Table on How to Order page for details.

**Style 55 Rod End**

MM Rod Ø	AD	AE +.001 -.001	AF Ø	AM Ø	WG <sup>1</sup>
4.500	3.19	1.499	3.50	4.45	6.50
5.000	3.19	1.499	3.88	4.95	6.63
5.500	3.94	1.874	4.38	5.45	7.50
7.000	4.06	1.999	5.75	6.95	8.44
8.000	4.06	1.999	6.50	7.95	8.69
9.000	4.63	2.374	7.25	8.95	8.75
10.000	4.63	2.374	8.00	9.95	9.75

**Tie Rods Extended Both Ends Mounting**  
**Style TD**  
 (NFPA Style MX1)

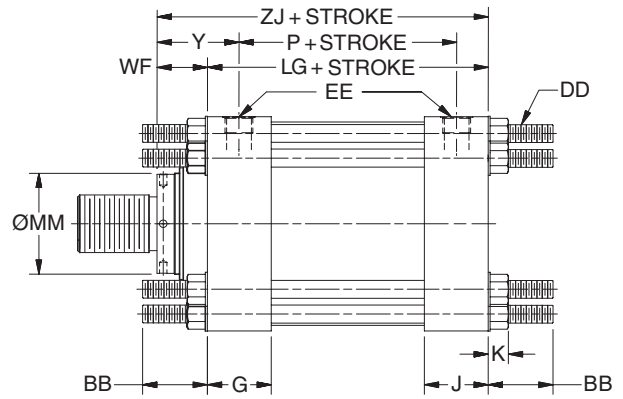
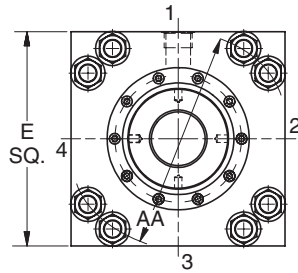
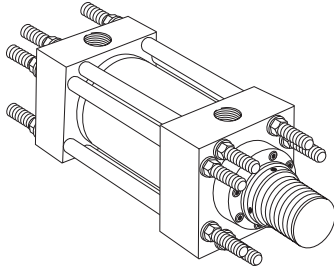

**Style TD – Dimensional and Mounting Data**

Bore Ø	Rod No.	MM Rod Ø	AA	BB	DD	E	EE			G	J	K Max.	WF	Y	Add Stroke		
							NPTF <sup>1</sup>	SAE Flange Ports <sup>2</sup>	SAE Straight Thread <sup>3</sup>						LG	P	ZJ
10.00	1 (std.)	4.500	13.00	4.13	1 1/8-12	12.63	2.00	2.00	24	3.69	3.69	1.17	2.94	4.75	12.13	8.50	15.06
	2	7.000	13.00	4.13	1 1/8-12	12.63	2.00	2.00	24	3.69	3.69	1.17	3.50	5.31	12.13	8.50	15.63
	3	5.000	13.00	4.13	1 1/8-12	12.63	2.00	2.00	24	3.69	3.69	1.17	3.19	5.00	12.13	8.50	15.31
	4	5.500	13.00	4.13	1 1/8-12	12.63	2.00	2.00	24	3.69	3.69	1.17	3.19	5.00	12.13	8.50	15.31
12.00	1 (std.)	5.500	15.50	4.50	1 1/4-12	14.88	2.50	2.50 <sup>4</sup>	24	4.44	4.44	1.30	3.19	5.38	14.50	10.13	17.69
	2	8.000	15.50	4.50	1 1/4-12	14.88	2.50	2.50 <sup>4</sup>	24	4.44	4.44	1.30	4.00	6.19	14.50	10.13	18.50
	3	7.000	15.50	4.50	1 1/4-12	14.88	2.50	2.50 <sup>4</sup>	24	4.44	4.44	1.30	3.50	5.69	14.50	10.13	18.00
14.00	1 (std.)	7.000	17.38	4.50	1 1/4-12	17.13	2.50	2.50 <sup>4</sup>	24	4.88	4.88	1.30	3.50	5.88	15.63	10.88	19.13
	2	10.000	17.38	4.50	1 1/4-12	17.13	2.50	2.50 <sup>4</sup>	24	4.88	4.88	1.30	4.50	6.88	15.63	10.88	20.13
	3	8.000	17.38	4.50	1 1/4-12	17.13	2.50	2.50 <sup>4</sup>	24	4.88	4.88	1.30	4.00	6.38	15.63	10.88	19.63

<sup>1</sup> NPTF ports are available at no extra charge.

<sup>2</sup> Optional SAE flange ports may be specified – flange to be supplied by customer. See Optional SAE Flange Port Pattern table for dimensions.

<sup>3</sup> SAE straight thread ports are standard and are indicated by port number.

<sup>4</sup> 2.50 SAE flange port is rated at 2500 psi

**Optional SAE Flange Port Pattern**

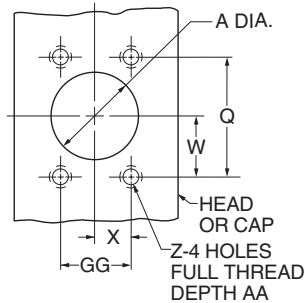

Nom. Flange Size	A	Q	GG	W	X	Z-THD UNC-2B	AA Min.	SAE
2	2.00	3.062	1.688	1.53	0.84	1/2-13	1.06	32
2 1/2	2.50	3.500	2.000	1.75	1.00	1/2-13	1.19	40

**Model 51 – Tie Rod Information**

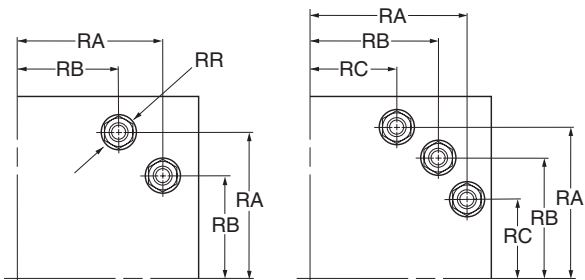

Bore Ø	10.00	12.00	14.00
Tie Rod Thread	1 1/8-12	1 1/4-12	1 1/4-12
RA	5.291	6.270	7.485
RB	3.775	4.555	6.143
RC	—	—	4.409
RR	2.00	2.19	2.19

**Style TB**

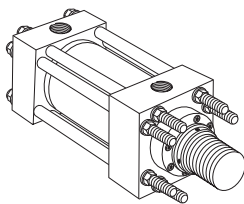

**Style TC**

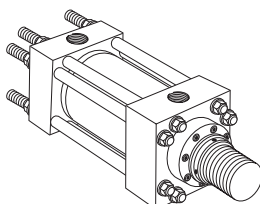

Dimensions for TB and TC may be obtained from the above dimensional table.

10.00" - 20.00" Bore  
 H Series



**Side Lugs Mounting**  
**Style C**  
**(NFPA Style MS2)**

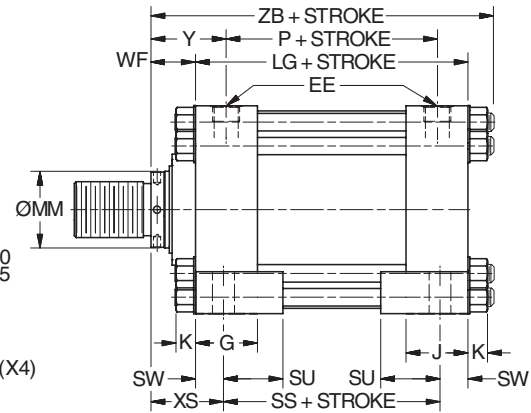
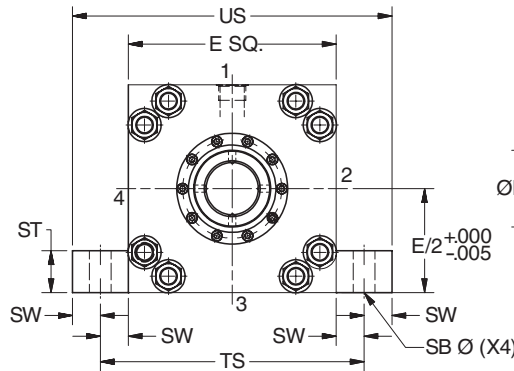
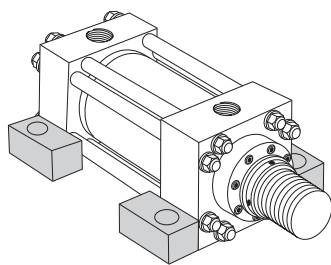

**Style C – Dimensional and Mounting Data**

Bore Ø	Rod No.	MM Rod Ø	E	Ports (EE)			G	J	K Max.	SB Ø	ST	SU	SW	Y	TS	US	WF	XS
				NPTF <sup>1</sup>	SAE Flange Port <sup>2</sup>	SAE Straight Thread Port <sup>3</sup>												
10.00	1 (std.)	4.500	12.63	2.00	2.00	24	3.69	3.69	1.17	1.563	2.25	3.50	1.63	4.75	15.88	19.13	2.94	4.56
	2	7.000	12.63	2.00	2.00	24	3.69	3.69	1.17	1.563	2.25	3.50	1.63	5.31	15.88	19.13	3.50	5.13
	3	5.000	12.63	2.00	2.00	24	3.69	3.69	1.17	1.563	2.25	3.50	1.63	5.00	15.88	19.13	3.19	4.81
	4	5.500	12.63	2.00	2.00	24	3.69	3.69	1.17	1.563	2.25	3.50	1.63	5.00	15.88	19.13	3.19	4.81
12.00	1 (std.)	5.500	14.88	2.50	2.50 <sup>4</sup>	24	4.44	4.44	1.30	1.563	3.00	4.25	2.00	5.38	18.88	22.88	3.19	5.19
	2	8.000	14.88	2.50	2.50 <sup>4</sup>	24	4.44	4.44	1.30	1.563	3.00	4.25	2.00	6.19	18.88	22.88	4.00	6.00
	3	7.000	14.88	2.50	2.50 <sup>4</sup>	24	4.44	4.44	1.30	1.563	3.00	4.25	2.00	5.69	18.88	22.88	3.50	5.50
14.00	1 (std.)	7.000	17.13	2.50	2.50 <sup>4</sup>	24	4.88	4.88	1.30	2.313	4.00	4.75	2.25	5.88	21.63	26.13	3.50	5.75
	2	10.000	17.13	2.50	2.50 <sup>4</sup>	24	4.88	4.88	1.30	2.313	4.00	4.75	2.25	6.88	21.63	26.13	4.50	6.75
	3	8.000	17.13	2.50	2.50 <sup>4</sup>	24	4.88	4.88	1.30	2.313	4.00	4.75	2.25	6.38	21.63	26.13	4.00	6.25

<sup>1</sup>NPTF ports are available at no extra charge.

<sup>2</sup>Optional SAE flange ports may be specified – flange to be supplied by customer. See Optional SAE Flange Port Pattern table for dimensions.

<sup>3</sup>SAE straight thread ports are standard and are indicated by port number.

<sup>4</sup>2.50 SAE flange port is rated at 2500 psi

**Style C – Dimensional and Mounting Data (cont.)**

Bore Ø	Rod No.	MM Rod Ø	Add Stroke			
			LG	P	SS	ZB Max.
10.00	1 (std.)	4.500	12.13	8.50	8.88	16.49
	2	7.000	12.13	8.50	8.88	17.05
	3	5.000	12.13	8.50	8.88	16.74
	4	5.500	12.13	8.50	8.88	16.74
12.00	1 (std.)	5.500	14.50	10.13	10.50	19.24
	2	8.000	14.50	10.13	10.50	20.05
	3	7.000	14.50	10.13	10.50	19.55
14.00	1 (std.)	7.000	15.63	10.88	11.13	20.68
	2	10.000	15.63	10.88	11.13	21.68
	3	8.000	15.63	10.88	11.13	21.18

**Optional SAE Flange Port Pattern**

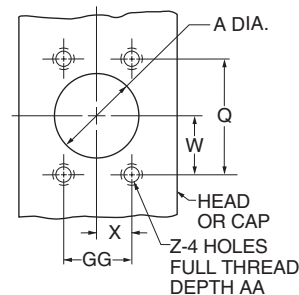

Nom. Flange Size	A	Q	GG	W	X	Z-THD UNC-2B	AA Min.	SAE
2	2.00	3.062	1.688	1.53	0.84	1/2-13	1.06	32
2 1/2	2.50	3.500	2.000	1.75	1.00	1/2-13	1.19	40

**Head Rectangular Mounting**

Style JJ  
 (NFA Style ME5)

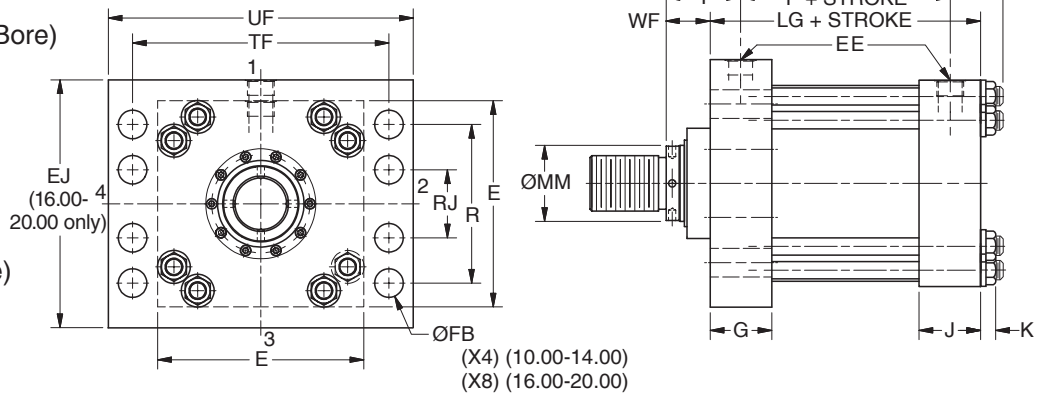
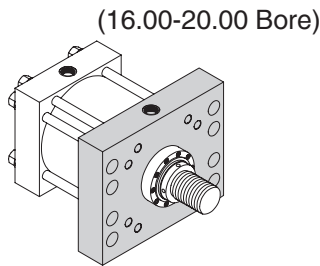
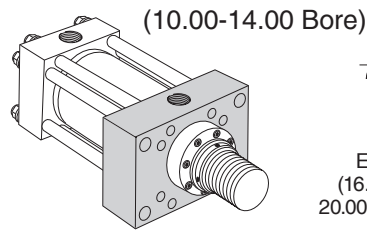

**Style JJ – Dimensional and Mounting Data**

Bore Ø	Rod No.	MM Rod Ø	E	EJ	Ports (EE)			FB Ø	G	J	K Max.	R	RJ	TF	UF	WF	Y	Add Stroke		
					NPTF <sup>1</sup>	SAE Flange Port <sup>2</sup>	SAE Straight Thread Port <sup>3</sup>											LG	P	ZB Max.
10.00	1 (std.)	4.500	12.63	-	2.00	2.00	24	1.81	3.69	3.69	1.17	9.62	-	15.88	19.00	2.94	4.75	12.13	8.50	16.49
	2	7.000	12.63	-	2.00	2.00	24	1.81	3.69	3.69	1.17	9.62	-	15.88	19.00	3.50	5.31	12.13	8.50	17.05
	3	5.000	12.63	-	2.00	2.00	24	1.81	3.69	3.69	1.17	9.62	-	15.88	19.00	3.19	5.00	12.13	8.50	16.74
	4	5.500	12.63	-	2.00	2.00	24	1.81	3.69	3.69	1.17	9.62	-	15.88	19.00	3.19	5.00	12.13	8.50	16.74
12.00	1 (std.)	5.500	14.88	-	2.50	2.50 <sup>4</sup>	24	2.06	4.44	4.44	1.30	11.45	-	18.50	22.00	3.19	5.38	14.50	10.13	19.24
	2	8.000	14.88	-	2.50	2.50 <sup>4</sup>	24	2.06	4.44	4.44	1.30	11.45	-	18.50	22.00	4.00	6.19	14.50	10.13	20.05
	3	7.000	14.88	-	2.50	2.50 <sup>4</sup>	24	2.06	4.44	4.44	1.30	11.45	-	18.50	22.00	3.50	5.69	14.50	10.13	19.55
14.00	1 (std.)	7.000	17.13	-	2.50	2.50 <sup>4</sup>	24	2.31	4.88	4.88	1.30	13.26	-	21.00	25.00	3.50	5.88	15.63	10.88	20.68
	2	10.000	17.13	-	2.50	2.50 <sup>4</sup>	24	2.31	4.88	4.88	1.30	13.26	-	21.00	25.00	4.50	6.88	15.63	10.88	21.68
	3	8.000	17.13	-	2.50	2.50 <sup>4</sup>	24	2.31	4.88	4.88	1.30	13.26	-	21.00	25.00	4.00	6.38	15.63	10.88	21.18
16.00	1 (std.)	8.000	19.00	20.00	-	3.00 <sup>5</sup>	24	1.81	5.88	5.88	1.70	15.50	8.00	21.00	24.50	4.00	7.00	18.13	12.13	24.08
	3	9.000	19.00	20.00	-	3.00 <sup>5</sup>	24	1.81	5.88	5.88	1.70	15.50	8.00	21.00	24.50	4.25	7.25	18.13	12.13	24.33
	4	10.000	19.00	20.00	-	3.00 <sup>5</sup>	24	1.81	5.88	5.88	1.70	15.50	8.00	21.00	24.50	4.50	7.50	18.13	12.13	24.58
18.00	1 (std.)	9.000	22.00	23.00	-	3.00 <sup>5</sup>	24	2.06	6.88	6.88	1.70	18.00	7.25	24.25	28.25	4.25	7.25	21.13	15.13	27.33
	3	10.000	22.00	23.00	-	3.00 <sup>5</sup>	24	2.06	6.88	6.88	1.70	18.00	7.25	24.25	28.25	4.50	7.50	21.13	15.13	27.58
20.00	1 (std.)	10.000	24.00	25.00	-	3.00 <sup>5</sup>	24	2.06	7.88	7.88	1.70	20.00	8.00	26.50	30.50	4.50	7.50	23.63	17.63	30.08

<sup>1</sup> NPTF ports are available at no extra charge.

<sup>2</sup> Optional SAE flange ports may be specified – flange to be supplied by customer. See Optional SAE Flange Port Pattern table for dimensions.

<sup>3</sup> SAE straight thread ports are standard and are indicated by port number.

<sup>4</sup> 2.50 SAE flange port is rated at 2500 psi

<sup>5</sup> 3.00 SAE flange port is rated at 2000 psi

**Optional SAE Flange Port Pattern**

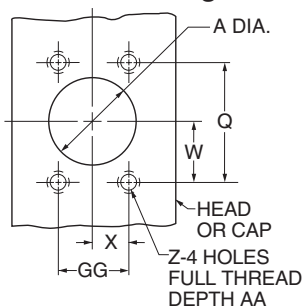

Nom. Flange Size	A	Q	GG	W	X	Z-THD UNC-2B	AA Min.	SAE
2	2.00	3.062	1.688	1.53	0.84	1/2-13	1.06	32
2 1/2	2.50	3.500	2.000	1.75	1.00	1/2-13	1.19	40
3	3.00	4.188	2.438	2.09	1.22	5/8-11	1.19	48

10.00" - 20.00" Bore  
 H Series

**Head Square Flange Mounting**  
**Style JB**  
**(NFPA Style MF5)**

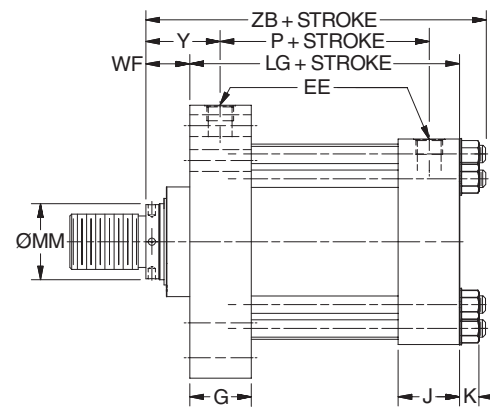
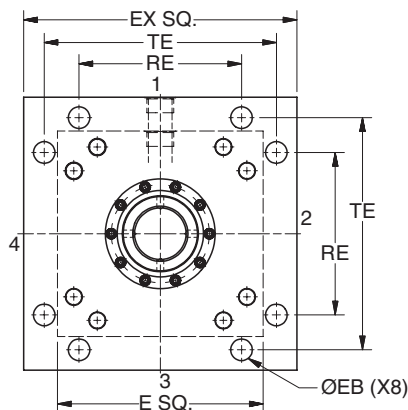
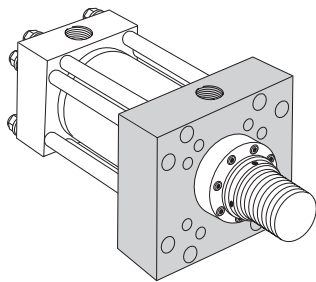

**Style JB – Dimensional and Mounting Data**

Bore Ø	MM Rod Ø	E	EB Ø	Ports (EE)			EX	G	J	K Max.	RE	TE	WF	Y	Add Stroke		
				NPTF <sup>1</sup>	SAE Flange Port <sup>2</sup>	SAE Straight Thread Port <sup>3</sup>									LG	P	ZB Max.
10.00	4.500	12.63	1.31	2.00	2.00	24	16.63	3.69	3.69	1.17	9.89	14.13	2.94	4.75	12.13	8.50	16.49
	5.000	12.63	1.31	2.00	2.00	24	16.63	3.69	3.69	1.17	9.89	14.13	3.19	5.00	12.13	8.50	16.74
	5.500	12.63	1.31	2.00	2.00	24	16.63	3.69	3.69	1.17	9.89	14.13	3.19	5.00	12.13	8.50	16.74
	7.000	12.63	1.31	2.00	2.00	24	16.63	3.69	3.69	1.17	9.89	14.13	3.50	5.31	12.13	8.50	17.05
12.00	5.500	14.88	1.56	2.50	2.50 <sup>4</sup>	24	19.75	4.44	4.44	1.30	11.75	16.79	3.19	5.38	14.50	10.13	19.24
	7.000	14.88	1.56	2.50	2.50 <sup>4</sup>	24	19.75	4.44	4.44	1.30	11.75	16.79	3.50	5.69	14.50	10.13	19.55
	8.000	14.88	1.56	2.50	2.50 <sup>4</sup>	24	19.75	4.44	4.44	1.30	11.75	16.79	4.00	6.19	14.50	10.13	20.05
14.00	7.000	17.13	1.81	2.50	2.50 <sup>4</sup>	24	21.75	4.88	4.88	1.30	12.90	18.43	3.50	5.88	15.63	10.88	20.68
	8.000	17.13	1.81	2.50	2.50 <sup>4</sup>	24	21.75	4.88	4.88	1.30	12.90	18.43	4.00	6.38	15.63	10.88	21.18
	10.000	17.13	1.81	2.50	2.50 <sup>4</sup>	24	21.75	4.88	4.88	1.30	12.90	18.43	4.50	6.88	15.63	10.88	21.68
16.00	8.000	19.00	1.81	-	3.00 <sup>5</sup>	24	24.50	5.88	5.88	1.70	15.28	21.03	4.00	7.00	18.13	12.13	24.08
	9.000	19.00	1.81	-	3.00 <sup>5</sup>	24	24.50	5.88	5.88	1.70	15.28	21.03	4.25	7.25	18.13	12.13	24.33
	10.000	19.00	1.81	-	3.00 <sup>5</sup>	24	24.50	5.88	5.88	1.70	15.28	21.03	4.50	7.50	18.13	12.13	24.58
18.00	9.000	22.00	2.06	-	3.00 <sup>5</sup>	24	26.50	6.88	6.88	1.70	16.45	22.65	4.25	7.25	21.13	15.13	27.33
	10.000	22.00	2.06	-	3.00 <sup>5</sup>	24	26.50	6.88	6.88	1.70	16.45	22.65	4.50	7.50	21.13	15.13	27.58
20.00	10.000	24.00	2.06	-	3.00 <sup>5</sup>	24	29.00	7.88	7.88	1.70	18.07	24.87	4.50	7.50	23.63	17.63	30.08

<sup>1</sup> NPTF ports are available at no extra charge.

<sup>2</sup> Optional SAE flange ports may be specified – flange to be supplied by customer. See Optional SAE Flange Port Pattern table for dimensions.

<sup>3</sup> SAE straight thread ports are standard and are indicated by port number.

<sup>4</sup> 2.50 SAE flange port is rated at 2500 psi

<sup>5</sup> 3.00 SAE flange port is rated at 2000 psi

**Optional SAE Flange Port Pattern**

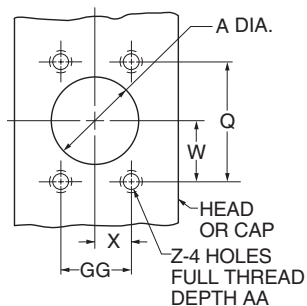

Nom. Flange Size	A	Q	GG	W	X	Z-THD UNC-2B	AA Min.	SAE
2	2.00	3.062	1.688	1.53	0.84	1/2-13	1.06	32
2 1/2	2.50	3.500	2.000	1.75	1.00	1/2-13	1.19	40
3	3.00	4.188	2.438	2.09	1.22	5/8-11	1.19	48

**Cap Rectangular Mounting**  
 Style HH  
 (NFPA Style ME6)

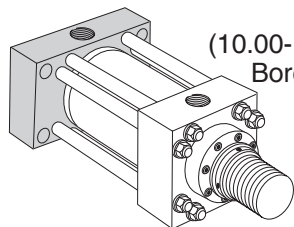

(10.00-14.00 Bore)

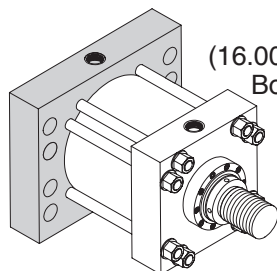

(16.00-20.00 Bore)

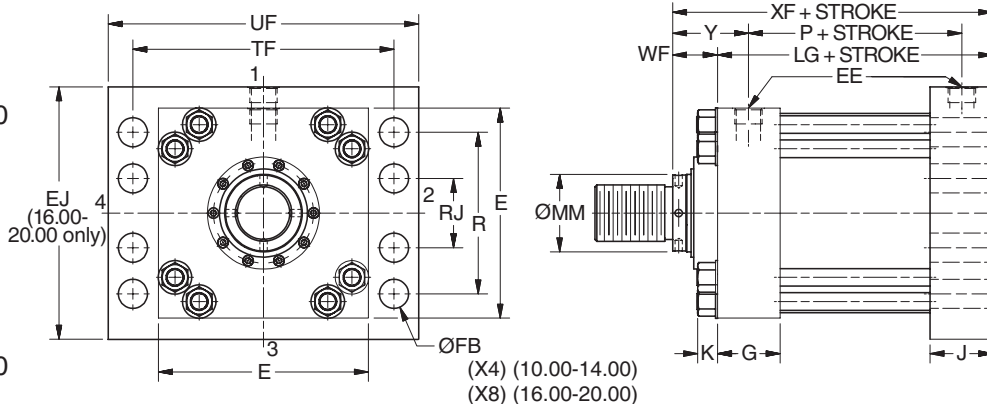

**Style HH – Dimensional and Mounting Data**

Bore Ø	MM Rod Ø	E	Ports (EE)			EJ	FB Ø	G	J	K Max.	R	RJ	TF	UF	WF	Y	Add Stroke		
			NPTF <sup>1</sup>	SAE Flange Port <sup>2</sup>	SAE Straight Thread Port <sup>3</sup>												LG	P	XF
10.00	4.500	12.63	2.00	2.00	24	-	1.81	3.69	3.69	1.17	9.62	-	15.88	19.00	2.94	4.75	12.13	8.50	15.06
	5.000	12.63	2.00	2.00	24	-	1.81	3.69	3.69	1.17	9.62	-	15.88	19.00	3.19	5.00	12.13	8.50	15.31
	5.500	12.63	2.00	2.00	24	-	1.81	3.69	3.69	1.17	9.62	-	15.88	19.00	3.19	5.00	12.13	8.50	15.31
	7.000	12.63	2.00	2.00	24	-	1.81	3.69	3.69	1.17	9.62	-	15.88	19.00	3.50	5.31	12.13	8.50	15.63
12.00	5.500	14.88	2.50	2.50 <sup>4</sup>	24	-	2.06	4.44	4.44	1.30	11.45	-	18.50	22.00	3.19	5.38	14.50	10.13	17.69
	7.000	14.88	2.50	2.50 <sup>4</sup>	24	-	2.06	4.44	4.44	1.30	11.45	-	18.50	22.00	3.50	5.69	14.50	10.13	18.00
	8.000	14.88	2.50	2.50 <sup>4</sup>	24	-	2.06	4.44	4.44	1.30	11.45	-	18.50	22.00	4.00	6.19	14.50	10.13	18.50
14.00	7.000	17.13	2.50	2.50 <sup>4</sup>	24	-	2.31	4.88	4.88	1.30	13.26	-	21.00	25.00	3.50	5.88	15.63	10.88	19.13
	8.000	17.13	2.50	2.50 <sup>4</sup>	24	-	2.31	4.88	4.88	1.30	13.26	-	21.00	25.00	4.00	6.38	15.63	10.88	19.63
	10.000	17.13	2.50	2.50 <sup>4</sup>	24	-	2.31	4.88	4.88	1.30	13.26	-	21.00	25.00	4.50	6.88	15.63	10.88	20.13
16.00	8.000	19.00	-	3.00 <sup>5</sup>	24	20.00	1.81	5.88	5.88	1.70	15.50	8.00	21.00	24.50	4.00	7.00	18.13	12.13	22.13
	9.000	19.00	-	3.00 <sup>5</sup>	24	20.00	1.81	5.88	5.88	1.70	15.50	8.00	21.00	24.50	4.25	7.25	18.13	12.13	22.38
	10.000	19.00	-	3.00 <sup>5</sup>	24	20.00	1.81	5.88	5.88	1.70	15.50	8.00	21.00	24.50	4.50	7.50	18.13	12.13	22.63
18.00	9.000	22.00	-	3.00 <sup>5</sup>	24	23.00	2.06	6.88	6.88	1.70	18.00	7.25	24.25	28.25	4.25	7.25	21.13	15.13	25.38
	10.000	22.00	-	3.00 <sup>5</sup>	24	23.00	2.06	6.88	6.88	1.70	18.00	7.25	24.25	28.25	4.50	7.50	21.13	15.13	25.63
20.00	10.000	24.00	-	3.00 <sup>5</sup>	24	25.00	2.06	7.88	7.88	1.70	20.00	8.00	26.50	30.50	4.50	7.50	23.63	17.63	28.13

<sup>1</sup>NPTF ports are available at no extra charge.

<sup>2</sup>Optional SAE flange ports may be specified – flange to be supplied by customer. See Optional SAE Flange Port Pattern table for dimensions.

<sup>3</sup>SAE straight thread ports are standard and are indicated by port number.

<sup>4</sup> 2.50 SAE flange port is rated at 2500 psi

<sup>5</sup> 3.00 SAE flange port is rated at 2000 psi

**Optional SAE Flange Port Pattern**

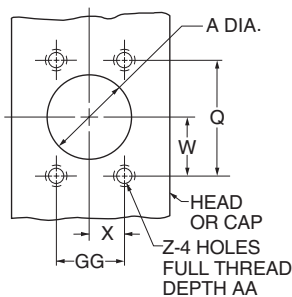

Nom. Flange Size	A	Q	GG	W	X	Z-THD UNC-2B	AA Min.	SAE
2	2.00	3.062	1.688	1.53	0.84	1/2-13	1.06	32
2 1/2	2.50	3.500	2.000	1.75	1.00	1/2-13	1.19	40
3	3.00	4.188	2.438	2.09	1.22	5/8-11	1.19	48

10.00" - 20.00" Bore  
 H Series

**Cap Square Flange Mounting**  
 Style HB  
 (NFPA Style MF6)

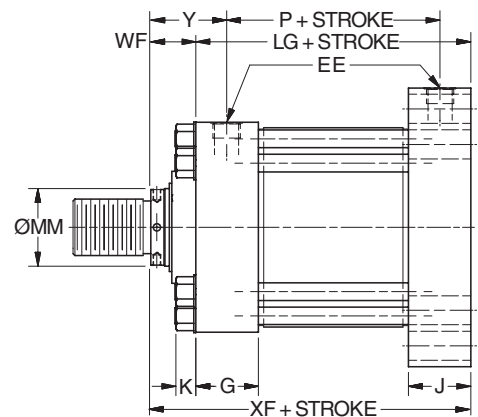
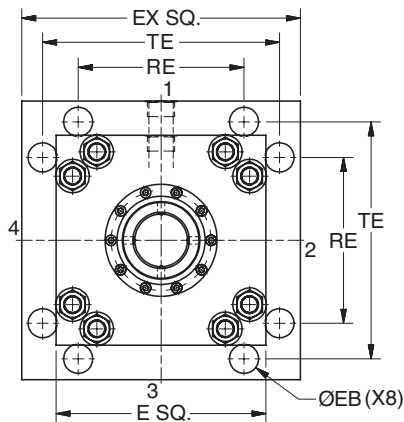
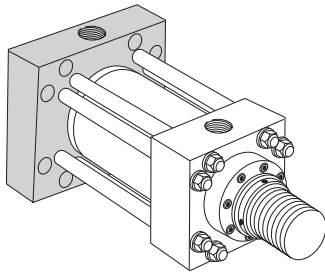

**Style HB – Dimensional and Mounting Data**

Bore Ø	MM Rod Ø	E	EB Ø	Ports (EE)			EX	G	J	K Max.	RE	TE	WF	Y	Add Stroke		
				NPTF <sup>1</sup>	SAE Flange Port <sup>2</sup>	SAE Straight Thread Port <sup>3</sup>									LG	P	XF
10.00	4.500	12.63	1.31	2.00	2.00	24	16.63	3.69	3.69	1.17	9.89	14.13	2.94	4.75	12.13	8.50	15.06
	5.000	12.63	1.31	2.00	2.00	24	16.63	3.69	3.69	1.17	9.89	14.13	3.19	5.00	12.13	8.50	15.31
	5.500	12.63	1.31	2.00	2.00	24	16.63	3.69	3.69	1.17	9.89	14.13	3.19	5.00	12.13	8.50	15.31
	7.000	12.63	1.31	2.00	2.00	24	16.63	3.69	3.69	1.17	9.89	14.13	3.50	5.31	12.13	8.50	15.63
12.00	5.500	14.88	1.56	2.50	2.50 <sup>4</sup>	24	19.75	4.44	4.44	1.30	11.75	16.79	3.19	5.38	14.50	10.13	17.69
	7.000	14.88	1.56	2.50	2.50 <sup>4</sup>	24	19.75	4.44	4.44	1.30	11.75	16.79	3.50	5.69	14.50	10.13	18.00
	8.000	14.88	1.56	2.50	2.50 <sup>4</sup>	24	19.75	4.44	4.44	1.30	11.75	16.79	4.00	6.19	14.50	10.13	18.50
14.00	7.000	17.13	1.81	2.50	2.50 <sup>4</sup>	24	21.75	4.88	4.88	1.30	12.90	18.43	3.50	5.88	15.63	10.88	19.13
	8.000	17.13	1.81	2.50	2.50 <sup>4</sup>	24	21.75	4.88	4.88	1.30	12.90	18.43	4.00	6.38	15.63	10.88	19.63
	10.000	17.13	1.81	2.50	2.50 <sup>4</sup>	24	21.75	4.88	4.88	1.30	12.90	18.43	4.50	6.88	15.63	10.88	20.13
16.00	8.000	19.00	1.81	-	3.00 <sup>5</sup>	24	24.50	5.88	5.88	1.70	15.28	21.03	4.00	7.00	18.13	12.13	22.13
	9.000	19.00	1.81	-	3.00 <sup>5</sup>	24	24.50	5.88	5.88	1.70	15.28	21.03	4.25	7.25	18.13	12.13	22.38
	10.000	19.00	1.81	-	3.00 <sup>5</sup>	24	24.50	5.88	5.88	1.70	15.28	21.03	4.50	7.50	18.13	12.13	22.63
18.00	9.000	22.00	2.06	-	3.00 <sup>5</sup>	24	26.50	6.88	6.88	1.70	16.45	22.65	4.25	7.25	21.13	15.13	25.38
	10.000	22.00	2.06	-	3.00 <sup>5</sup>	24	26.50	6.88	6.88	1.70	16.45	22.65	4.50	7.50	21.13	15.13	25.63
20.00	10.000	24.00	2.06	-	3.00 <sup>5</sup>	24	29.00	7.88	7.88	1.70	18.07	24.87	4.50	7.50	23.63	17.63	28.13

<sup>1</sup>NPTF ports are available at no extra charge.

<sup>2</sup>Optional SAE flange ports may be specified – flange to be supplied by customer. See Optional SAE Flange Port Pattern table for dimensions.

<sup>3</sup>SAE straight thread ports are standard and are indicated by port number.

<sup>4</sup> 2.50 SAE flange port is rated at 2500 psi

<sup>5</sup> 3.00 SAE flange port is rated at 2000 psi

**Optional SAE Flange Port Pattern**

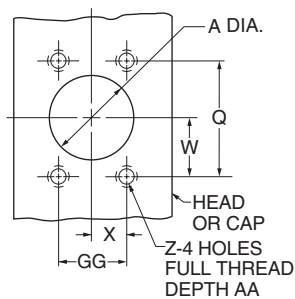

Nom. Flange Size	A	Q	GG	W	X	Z-THD UNC-2B	AA Min.	SAE
2	2.00	3.062	1.688	1.53	0.84	1/2-13	1.06	32
2 1/2	2.50	3.500	2.000	1.75	1.00	1/2-13	1.19	40
3	3.00	4.188	2.438	2.09	1.22	5/8-11	1.19	48

**Cap Fixed Clevis Mounting**  
 Style BB(NFPA Style MP1)

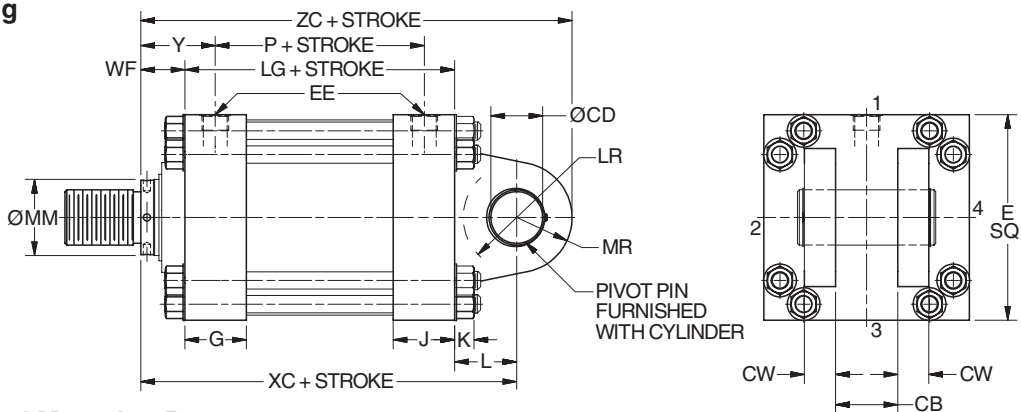
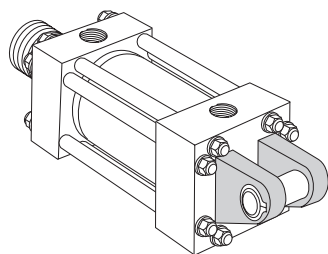

**Style BB – Dimensional and Mounting Data**

Bore Ø	MM Rod Ø	CB	CD <sup>4</sup> Ø +.000 - .002	CW	E	EE Ports			G	J	K Max.	L	LR	MR	WF	Y	Add Stroke			
						NPTF <sup>1</sup>	SAE Flange Port <sup>2</sup>	SAE Straight Thread Port <sup>3</sup>									LG	P	XC	ZC
10.00	4.500	4.00	3.501	2.00	12.63	2.00	2.00	24	3.69	3.69	1.17	4.00	3.38	3.50	2.94	4.75	12.13	8.50	19.06	22.56
	5.000	4.00	3.501	2.00	12.63	2.00	2.00	24	3.69	3.69	1.17	4.00	3.38	3.50	3.19	5.00	12.13	8.50	19.31	22.81
	5.500	4.00	3.501	2.00	12.63	2.00	2.00	24	3.69	3.69	1.17	4.00	3.38	3.50	3.19	5.00	12.13	8.50	19.31	22.81
	7.000	4.00	3.501	2.00	12.63	2.00	2.00	24	3.69	3.69	1.17	4.00	3.38	3.50	3.50	5.31	12.13	8.50	19.63	23.13
12.00	5.500	4.50	4.001	2.25	14.88	2.50	2.50 <sup>5</sup>	24	4.44	4.44	1.30	4.50	3.88	4.00	3.19	5.38	14.50	10.13	22.19	26.19
	7.000	4.50	4.001	2.25	14.88	2.50	2.50 <sup>5</sup>	24	4.44	4.44	1.30	4.50	3.88	4.00	3.50	5.69	14.50	10.13	22.50	26.50
	8.000	4.50	4.001	2.25	14.88	2.50	2.50 <sup>5</sup>	24	4.44	4.44	1.30	4.50	3.88	4.00	4.00	6.19	14.50	10.13	23.00	27.00
14.00	7.000	6.00	5.001	3.00	17.13	2.50	2.50 <sup>5</sup>	24	4.88	4.88	1.30	5.75	4.19	5.00	3.50	5.88	15.63	10.88	24.88	29.88
	8.000	6.00	5.001	3.00	17.13	2.50	2.50 <sup>5</sup>	24	4.88	4.88	1.30	5.75	4.19	5.00	4.00	6.38	15.63	10.88	25.38	30.38
	10.000	6.00	5.001	3.00	17.13	2.50	2.50 <sup>5</sup>	24	4.88	4.88	1.30	5.75	4.19	5.00	4.50	6.88	15.63	10.88	25.88	30.88
16.00	8.000	7.00	6.001	3.50	19.00	-	3.00 <sup>6</sup>	24	5.88	5.88	1.70	7.00	6.25	6.00	4.00	7.00	18.13	12.13	29.13	35.13
	9.000	7.00	6.001	3.50	19.00	-	3.00 <sup>6</sup>	24	5.88	5.88	1.70	7.00	6.25	6.00	4.25	7.25	18.13	12.13	29.38	35.38
	10.000	7.00	6.001	3.50	19.00	-	3.00 <sup>6</sup>	24	5.88	5.88	1.70	7.00	6.25	6.00	4.50	7.50	18.13	12.13	29.63	35.63
18.00	9.000	8.00	6.501	4.00	22.00	-	3.00 <sup>6</sup>	24	6.88	6.88	1.70	7.63	6.75	6.50	4.25	7.25	21.13	15.13	33.00	39.50
	10.000	8.00	6.501	4.00	22.00	-	3.00 <sup>6</sup>	24	6.88	6.88	1.70	7.63	6.75	6.50	4.50	7.50	21.13	15.13	33.25	39.75
20.00	10.000	9.00	7.501	4.50	24.00	-	3.00 <sup>6</sup>	24	7.88	7.88	1.70	8.75	7.75	7.50	4.50	7.50	23.63	17.63	36.88	44.38

<sup>1</sup>NPTF ports are available at no extra charge.

<sup>2</sup>Optional SAE flange ports may be specified – flange to be supplied by customer. See Optional SAE Flange Port Pattern table for dimensions.

<sup>3</sup>SAE straight thread ports are standard and are indicated by port number.

<sup>4</sup>Diameter CD is pin diameter.

<sup>5</sup>2.50 SAE flange port is rated at 2500 psi

<sup>6</sup>3.00 SAE flange port is rated at 2000 psi

**Optional SAE Flange Port Pattern**

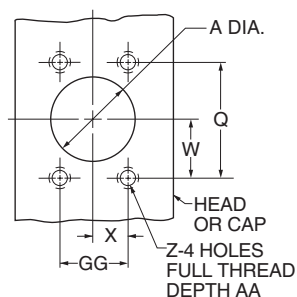

Nom. Flange Size	A	Q	GG	W	X	Z-THD UNC-2B	AA Min.	SAE
2	2.00	3.062	1.688	1.53	0.84	1/2-13	1.06	32
2 1/2	2.50	3.500	2.000	1.75	1.00	1/2-13	1.19	40
3	3.00	4.188	2.438	2.09	1.22	5/8-11	1.19	48

10.00" - 20.00" Bore  
 H Series



**Head Trunnion Mounting**  
**Style D**  
(NFPA Style MT1)

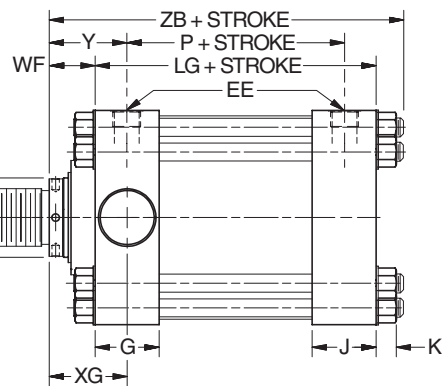
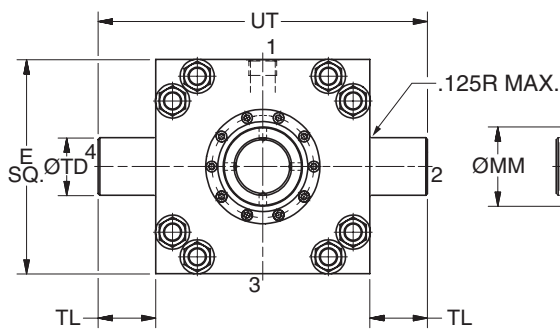
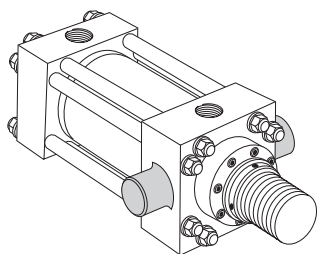

**Style D – Dimensional and Mounting Data**

Bore Ø	MM Rod Ø	E	Ports (EE)			G	J	K Max.	TD Ø +.000 -.001	TL	UT	WF	XG	Y	Add Stroke		
			NPTF <sup>1</sup>	SAE Flange Port <sup>2</sup>	SAE Straight Thread Port <sup>3</sup>										LG	P	ZB Max.
10.00	4.500	12.63	2.00	2.00	24	3.69	3.69	1.17	3.500	3.50	19.63	2.94	4.75	4.75	12.13	8.50	16.49
	5.000	12.63	2.00	2.00	24	3.69	3.69	1.17	3.500	3.50	19.63	3.19	5.00	5.00	12.13	8.50	16.74
	5.500	12.63	2.00	2.00	24	3.69	3.69	1.17	3.500	3.50	19.63	3.19	5.00	5.00	12.13	8.50	16.74
	7.000	12.63	2.00	2.00	24	3.69	3.69	1.17	3.500	3.50	19.63	3.50	5.31	5.31	12.13	8.50	17.05
12.00	5.500	14.88	2.50	2.50 <sup>4</sup>	24	4.44	4.44	1.30	4.000	4.00	22.88	3.19	5.38	5.38	14.50	10.13	19.24
	7.000	14.88	2.50	2.50 <sup>4</sup>	24	4.44	4.44	1.30	4.000	4.00	22.88	3.50	5.69	5.69	14.50	10.13	19.55
	8.000	14.88	2.50	2.50 <sup>4</sup>	24	4.44	4.44	1.30	4.000	4.00	22.88	4.00	6.19	6.19	14.50	10.13	20.05
14.00	7.000	17.13	2.50	2.50 <sup>4</sup>	24	4.88	4.88	1.30	4.500	4.50	26.13	3.50	5.94	5.88	15.63	10.88	20.68
	8.000	17.13	2.50	2.50 <sup>4</sup>	24	4.88	4.88	1.30	4.500	4.50	26.13	4.00	6.44	6.38	15.63	10.88	21.18
	10.000	17.13	2.50	2.50 <sup>4</sup>	24	4.88	4.88	1.30	4.500	4.50	26.13	4.50	6.94	6.88	15.63	10.88	21.68

<sup>1</sup> NPTF ports are available at no extra charge.

<sup>2</sup> Optional SAE flange ports may be specified – flange to be supplied by customer. See Optional SAE Flange Port Pattern table for dimensions.

<sup>3</sup> SAE straight thread ports are standard and are indicated by port number.

<sup>4</sup> 2.50 SAE flange port is rated at 2500 psi

**Style D – Maximum Operating Pressure**

Bore Ø	psi
10.00	2800
12.00	2350
14.00	2200

**Optional SAE Flange Port Pattern**

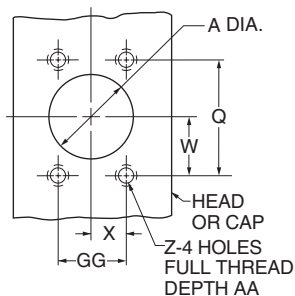

Nom. Flange Size	A	Q	GG	W	X	Z-THD UNC-2B	AA Min.	SAE
2	2.00	3.062	1.688	1.53	0.84	1/2-13	1.06	32
2 1/2	2.50	3.500	2.000	1.75	1.00	1/2-13	1.19	40

**Cap Trunnion Mounting**  
**Style DB**  
**(NFPA Style MT2)**

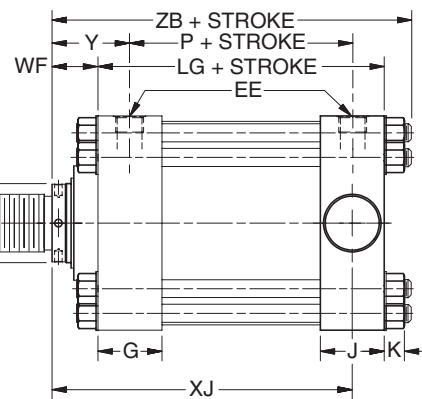
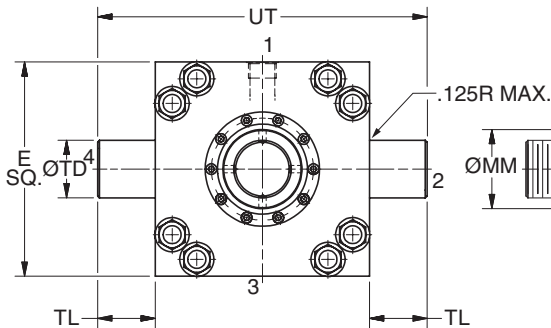
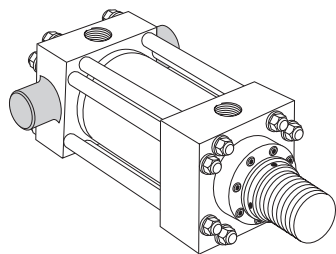

**Style DB – Dimensional and Mounting Data**

Bore Ø	MM Rod Ø	E	Ports (EE)			G	J	K Max.	TD Ø +.000 -.001	TL	UT	WF	Y	Add Stroke			
			NPTF <sup>1</sup>	SAE Flange Port <sup>2</sup>	SAE Straight Thread Port <sup>3</sup>									LG	P	XJ	ZB Max.
10.00	4.500	12.63	2.00	2.00	24	3.69	3.69	1.17	3.500	3.50	19.63	2.94	4.75	12.13	8.50	13.38	16.49
	5.000	12.63	2.00	2.00	24	3.69	3.69	1.17	3.500	3.50	19.63	3.19	5.00	12.13	8.50	13.63	16.74
	5.500	12.63	2.00	2.00	24	3.69	3.69	1.17	3.500	3.50	19.63	3.19	5.00	12.13	8.50	13.63	16.74
	7.000	12.63	2.00	2.00	24	3.69	3.69	1.17	3.500	3.50	19.63	3.50	5.31	12.13	8.50	13.94	17.05
12.00	5.500	14.88	2.50	2.50 <sup>4</sup>	24	4.44	4.44	1.30	4.000	4.00	22.88	3.19	5.38	14.50	10.13	15.50	19.24
	7.000	14.88	2.50	2.50 <sup>4</sup>	24	4.44	4.44	1.30	4.000	4.00	22.88	3.50	5.69	14.50	10.13	15.81	19.55
	8.000	14.88	2.50	2.50 <sup>4</sup>	24	4.44	4.44	1.30	4.000	4.00	22.88	4.00	6.19	14.50	10.13	16.31	20.05
14.00	7.000	17.13	2.50	2.50 <sup>4</sup>	24	4.88	4.88	1.30	4.500	4.50	26.13	3.50	5.88	15.63	10.88	16.69	20.68
	8.000	17.13	2.50	2.50 <sup>4</sup>	24	4.88	4.88	1.30	4.500	4.50	26.13	4.00	6.38	15.63	10.88	17.19	21.18
	10.000	17.13	2.50	2.50 <sup>4</sup>	24	4.88	4.88	1.30	4.500	4.50	26.13	4.50	6.88	15.63	10.88	17.69	21.68

<sup>1</sup> NPTF ports are available at no extra charge.

<sup>2</sup> Optional SAE flange ports may be specified – flange to be supplied by customer. See Optional SAE Flange Port Pattern table for dimensions.

<sup>3</sup> SAE straight thread ports are standard and are indicated by port number.

<sup>4</sup> 2.50 SAE flange port is rated at 2500 psi

**Optional SAE Flange Port Pattern**

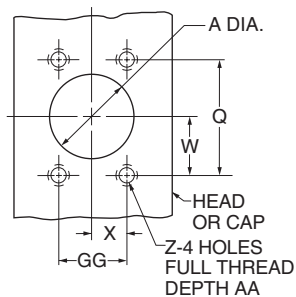

**Style DB – Maximum Operating Pressure**

Bore Ø	psi
10.00	2800
12.00	2350
14.00	2200

Nom. Flange Size	A	Q	GG	W	X	Z-THD UNC-2B	AA Min.	SAE
2	2.00	3.062	1.688	1.53	0.84	1/2-13	1.06	32
2 1/2	2.50	3.500	2.000	1.75	1.00	1/2-13	1.19	40

**Intermediate Fixed Trunnion Mounting**  
**Style DD)**  
**(NFPA Style MT4)**

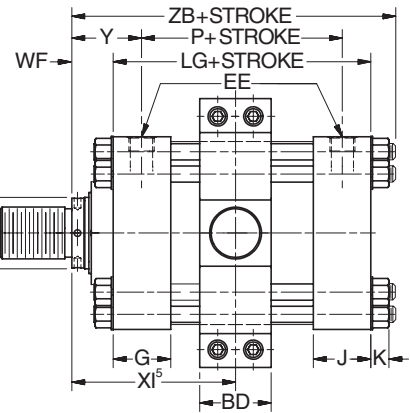
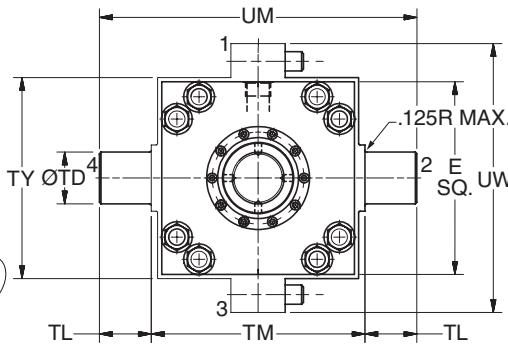
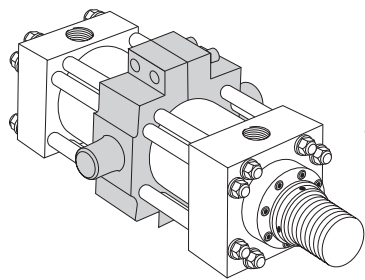

**Style DD – Dimensional and Mounting Data**

Bore Ø	MM Rod Ø	E	EE Ports			BD	G	J	K Max.	TD Ø +.000 - .001	TL	TM	TY	UM	UW	WF	Min. XI <sup>5</sup> Styles 2 & 4	Y	Add Stroke		
			NPTF <sup>1</sup>	SAE Flge. Port <sup>2</sup>	SAE Str. Thr. Port <sup>3</sup>														LG	P	ZB Max.
10.00	4.500	12.63	2.00	2.00	24	4.50	3.69	3.69	1.17	3.500	3.50	14.00	13.00	21.00	17.50	2.94	9.06	4.75	12.13	8.50	16.49
	5.000	12.63	2.00	2.00	24	4.50	3.69	3.69	1.17	3.500	3.50	14.00	13.00	21.00	17.50	3.19	9.31	5.00	12.13	8.50	16.74
	5.500	12.63	2.00	2.00	24	4.50	3.69	3.69	1.17	3.500	3.50	14.00	13.00	21.00	17.50	3.19	9.31	5.00	12.13	8.50	16.74
	7.000	12.63	2.00	2.00	24	4.50	3.69	3.69	1.17	3.500	3.50	14.00	13.00	21.00	17.50	3.50	9.63	5.31	12.13	8.50	17.05
12.00	5.500	14.88	2.50	2.50 <sup>6</sup>	24	5.50	4.44	4.44	1.30	4.000	4.00	16.50	15.50	24.50	20.75	3.19	10.63	5.38	14.50	10.13	19.24
	7.000	14.88	2.50	2.50 <sup>6</sup>	24	5.50	4.44	4.44	1.30	4.000	4.00	16.50	15.50	24.50	20.75	3.50	10.94	5.69	14.50	10.13	19.55
	8.000	14.88	2.50	2.50 <sup>6</sup>	24	5.50	4.44	4.44	1.30	4.000	4.00	16.50	15.50	24.50	20.75	4.00	11.50	6.19	14.50	10.13	20.05
14.00	7.000	17.13	2.50	2.50 <sup>6</sup>	24	5.50	4.88	4.88	1.30	4.500	4.50	19.50	19.25	28.50	24.75	3.50	11.44	5.88	15.63	10.88	20.68
	8.000	17.13	2.50	2.50 <sup>6</sup>	24	5.50	4.88	4.88	1.30	4.500	4.50	19.50	19.25	28.50	24.75	4.00	11.94	6.38	15.63	10.88	21.18
	10.000	17.13	2.50	2.50 <sup>6</sup>	24	5.50	4.88	4.88	1.30	4.500	4.50	19.50	19.25	28.50	24.75	4.50	12.44	6.88	15.63	10.88	21.68
16.00	8.000	19.00	4	3.00 <sup>7</sup>	24	4	5.88	5.88	1.70	4	4	4	4	4	4	4.00	4	7.00	18.13	12.13	24.08
	9.000	19.00	4	3.00 <sup>7</sup>	24	4	5.88	5.88	1.70	4	4	4	4	4	4	4.25	4	7.25	18.13	12.13	24.33
	10.000	19.00	4	3.00 <sup>7</sup>	24	4	5.88	5.88	1.70	4	4	4	4	4	4	4.50	4	7.50	18.13	12.13	24.58
18.00	9.000	22.00	4	3.00 <sup>7</sup>	24	4	6.88	6.88	1.70	4	4	4	4	4	4	4.25	4	7.25	21.13	15.13	27.33
	10.000	22.00	4	3.00 <sup>7</sup>	24	4	6.88	6.88	1.70	4	4	4	4	4	4	4.50	4	7.50	21.13	15.13	27.58
20.00	10.000	24.00	4	3.00 <sup>7</sup>	24	4	7.88	7.88	1.70	4	4	4	4	4	4	4.50	4	7.50	23.63	17.63	30.08

<sup>1</sup>NPTF ports are available at no extra charge.

<sup>2</sup>Optional SAE flange ports may be specified – flange to be supplied by customer. See Optional SAE Flange Port Pattern table for dimensions.

<sup>3</sup>SAE straight thread ports are standard and are indicated by port number.

<sup>4</sup>Consult Factory

<sup>5</sup>Dimension XI to be specified by customer. Reference point for rod end Style 9 is end of piston rod.

<sup>6</sup>2.50 SAE flange port is rated at 2500 psi

<sup>7</sup>3.00 SAE flange port is rated at 2000 psi

**Optional SAE Flange Port Pattern**

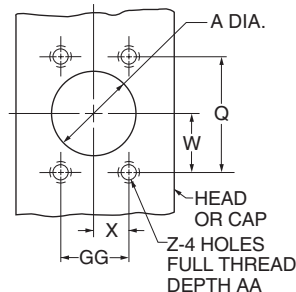

Nom. Flange Size	A	Q	GG	W	X	Z-THD UNC-2B	AA Min.	SAE
2	2.00	3.062	1.688	1.53	0.84	1/2-13	1.06	32
2 1/2	2.50	3.500	2.000	1.75	1.00	1/2-13	1.19	40
3	3.00	4.188	2.438	2.09	1.22	5/8-11	1.19	48

**Style DD – Maximum Operating Pressure**

Bore Ø	psi
10.00	2800
12.00	2350
14.00	2200

**Double Rod Cylinder**

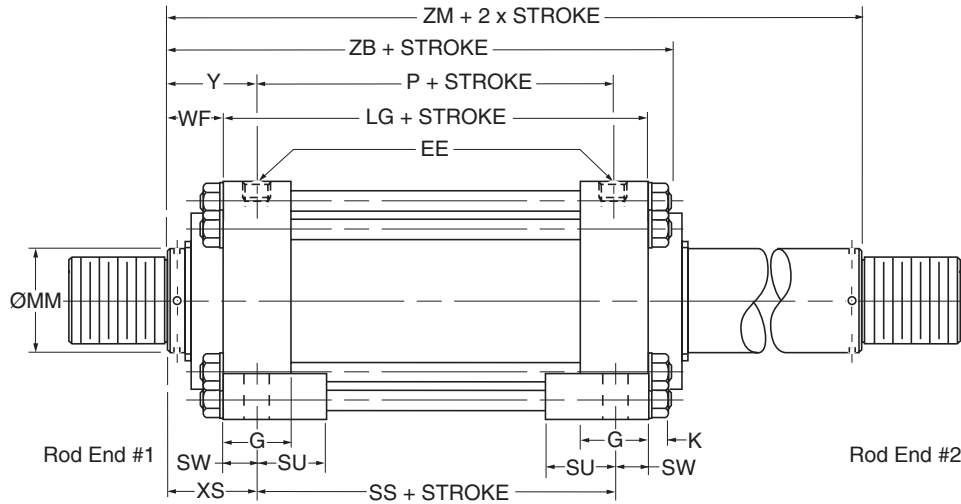

Mounting Styles for Single Rod Models	Mounting Styles for Corresponding Double Rod Models <sup>1</sup>	Dimension Shown on This Page Supplement Dimensions on Pages Listed Below
TB	KTB	50
TD	KTD	50
C	KC	51
JJ	KJJ	52
JB	KJB	53
D	KD	57
DD	KDD <sup>2</sup>	59

<sup>1</sup>If only one end of these Double Rod Cylinders is to be cushioned, be sure to specify clearly which end this will be.

<sup>2</sup>Specify XI dimension from rod end #1.

Bore Ø	Rod Code	Rod Ø	Add 2X Stroke
			ZM
10.00	1	4.500	18.00
	2	7.000	19.12
	3	5.000	18.50
	4	5.500	18.50
12.00	1	5.500	20.88
	2	8.000	22.50
	3	7.000	21.50
14.00	1	7.000	22.63
	2	10.000	24.63
	3	8.000	23.63
16.00	1	8.000	26.13
	3	9.000	26.63
	4	10.000	27.13
18.00	1	9.000	29.63
	3	10.000	30.13
20.00	1	10.000	32.63

**How to Use Double Rod Cylinder Dimension Drawings**

To obtain dimensioning information on a double rod cylinder, first select the desired mounting style and refer to the corresponding single rod cylinder model shown on the preceding pages. (See table above.) After you have determined all necessary dimensions from that drawing, turn back to this page and supplement those dimensions with additional ones from the drawing above and table at right. These added dimensions differ from, or are in addition to, those shown on the preceding pages and

provide the additional information needed to completely dimension a double rod cylinder model.

On a double rod cylinder where the two rod ends are different, be sure to clearly state which rod end is to be assembled at which end. Port position 1 is standard. If other than standard, specify pos. 2, 3 or 4 when viewed from rod end #1 only.

## Section D

### Engineering Data

Common & Custom Modifications ..... 62-63  
 Push & Pull Forces ..... 64-65  
 Global Shield™ Rod Coating ..... 66  
 Cylinder Weights ..... 67  
 Operating Fluids and Seals / Temperature Range ..... 68  
 Fluids and Temperature Range / Pressure Ratings ..... 69  
 Piston & Bushing Friction / Piston Orifice ..... 70-71  
 Ports ..... 72-73

Stroke Data / Mounting Groups ..... 74  
 Stop Tubing ..... 75  
 Piston Rod Selection Data ..... 76-78  
 Cushioning ..... 79-84  
 Support Literature ..... 86-87  
 Cylinder Safety Guide ..... 90-91  
 Offer of Sale ..... 92

### Rod Extension Dimensions for Buffer Seal Glands

Buffer Seal glands are from 0.31" to 0.81" longer (see table at right) than glands without a Buffer Seal. The longer gland causes the piston rod to extend beyond its location for a standard gland. A differentiating rod end style 4B vs. 4, 9B vs. 9 etc. must also be specified when selecting the Buffer Seal gland option. Rod end extension dimensions – V, VF, W, WF and WG – for Buffer Seal rod end styles are in the table at right. All other rod end dimensions are unchanged and can be found on the Piston Rod Ends page for each series.

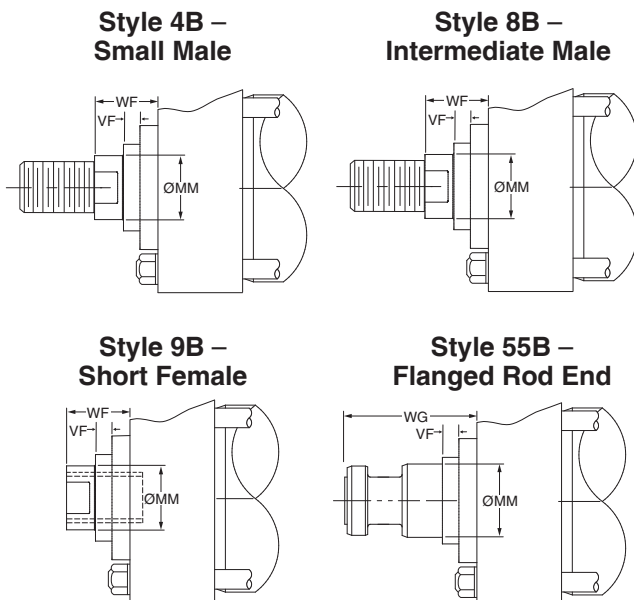

Bore Ø	Rod No.	MM Rod Ø	Gland Length Increase	V <sup>1</sup>	VF	W <sup>1</sup>	WF	WG <sup>2</sup>
1.50	1 (Std.)	0.625	Buffer Seal Not Available in 0.625" Rod					
	2	1.000	0.31	0.81	0.83	1.31	1.69	2.38
2.00	1 (Std.)	1.000	0.31	0.56	0.83	1.06	1.69	2.38
	2	1.375	0.38	0.75	1.02	1.38	2.00	2.75
2.50	1 (Std.)	1.000	0.31	0.56	0.83	1.06	1.69	2.38
	2	1.750	0.44	0.94	0.97	1.69	2.31	3.13
	3	1.375	0.38	0.75	1.02	1.38	2.00	2.75
3.25	1 (Std.)	1.375	0.38	0.63	1.02	1.25	2.00	2.75
	2	2.000	0.44	0.81	0.97	1.69	2.44	3.75
	3	1.750	0.44	0.81	0.97	1.56	2.31	3.13
4.00	1 (Std.)	1.750	0.44	0.69	0.97	1.44	2.31	3.13
	2	2.500	0.44	0.81	1.09	1.81	2.69	4.50
	3	2.000	0.44	0.69	0.97	1.56	2.44	3.75
5.00	1 (Std.)	2.000	0.44	0.69	0.97	1.56	2.44	3.75
	2	3.500	0.44	0.81	0.78	1.81	2.69	5.63
	3	2.500	0.44	0.81	1.09	1.81	2.69	4.50
	4	3.000	0.44	0.81	0.85	1.81	2.69	4.88
6.00	1 (Std.)	2.500	0.44	0.69	1.09	1.69	2.69	4.50
	2	4.000	0.44	0.69	0.78	1.69	2.69	5.75
	3	3.000	0.44	0.69	0.85	1.69	2.69	4.88
	4	3.500	0.44	0.69	0.78	1.69	2.69	5.63
7.00	1 (Std.)	3.000	0.44	1.06	0.84	1.69	2.69	4.88
	2	5.000	0.81	1.15	1.15	2.06	3.06	6.63
	3	3.500	0.44	1.07	0.78	1.69	2.69	5.63
	4	4.000	0.44	0.94	0.78	1.69	2.69	5.75
	5	4.500	0.44	0.94	0.78	1.69	2.69	6.50
8.00	1 (Std.)	3.500	0.44	1.06	0.78	1.69	2.69	5.63
	2	5.500	0.81	1.15	1.15	2.06	3.06	7.50
	3	4.000	0.44	0.94	0.78	1.69	2.69	5.75
	4	4.500	0.44	0.94	0.78	1.69	2.69	6.50
	5	5.000	0.81	1.15	1.15	2.06	3.06	6.63

<sup>1</sup> 'V' and "W" dimensions are for Mounting Styles J & JB and tie rod retained gland styles.

<sup>2</sup> The 'WG' dimension for Buffer Seal Glands matches the 'WG' for standard glands.



**Modifications:** The following modifications can be supplied on most Atlas cylinders.

**Metallic Rod Scraper**

When specified metallic rod scrapers can be supplied instead of the standard synthetic rubber wiperseal. Recommended in applications where contaminants tend to cling to the extended piston rod and would damage the synthetic rubber wiperseal. Installation of metallic rod scraper does not affect cylinder dimensions. It is available at extra cost.

**Atlas Crown Wiper™ for Series H and 7.00" & 8.00" bore**

For environments that contain fine abrasive particulate specify the Crown Wiper option. The Crown Wiper is a proven superior alternative to piston rod end boots or metallic wipers that can ingest particulate. It has a sharp leading edge to effectively clean the piston rod and a beveled shape to prevent contaminant intrusion by channeling it away from the bushing. It also acts as a secondary seal to wipe clean any oil film adhering to the rod on the extend stroke.

Standard Crown Wiper material for Seal Class 1 and 4 service is durable polyurethane. Optional FKM material is available for Class 5 service. The Crown Wiper requires a unique bushing but does not change cylinder mounting dimensions

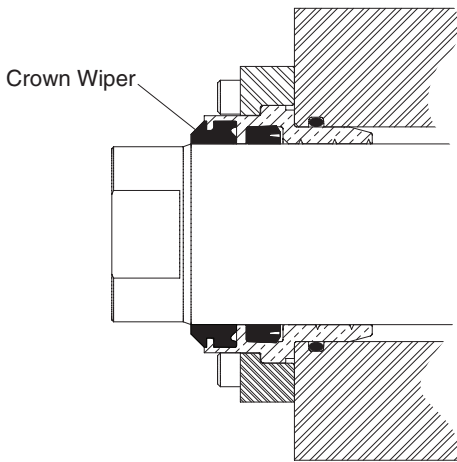

**Rod End Boots**

Cylinders have a hardened bearing surface on the piston rod to resist external damage, and are equipped with the high efficiency "Wiperseal" to remove external dust and dirt. Exposed piston rods that are subjected to contaminants with air hardening properties, such as paint, should be protected. In such applications, the use of a collapsing cover should be considered. This is commonly referred to as a "boot". Calculate the longer rod end required to accommodate the collapsed length of the boot from the following data.

<b>LF</b>	.13	.13	.13	.13	.13	.13	.10	.10	.10	.10	.10
<b>OD</b>	2.25	2.63	3.00	3.38	3.75	4.38	5.13	5.63	6.25	7.00	7.50
<b>MM</b>	.625	1.000	1.375	1.750	2.000	2.500	3.000	3.500	4.000	5.000	5.500

To determine extra length of piston rod required to accommodate boot, calculate  
 $BL = \text{Stroke} \times LF + 1.13"$   
 $BL + \text{Std. W or WF} + A = \text{length of piston rod to extend beyond the retainer.}$

NOTE: Check all Boot O.D's against std. "E" dimension from catalog. This may be critical on foot mounted cylinders.

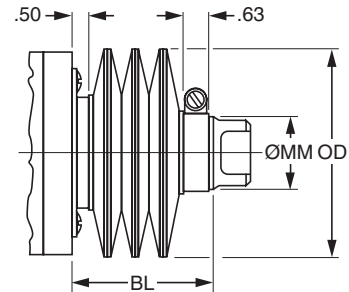

**Bushing Drain**

Hydraulic fluids tend to adhere to the piston rods, during the extend stroke, and an accumulation of fluid can collect in the cavity behind the bushing wiperseal on long stroke cylinders.

A 1/8" NPTF bushing drain port can be provided in the bushing retainer. A passage in the bushing between the wiperseal and lipseal is provided to drain off any accumulation of fluid between the seals. See drawing below.

It is recommended that the bushing drain port be piped back to the fluid reservoir and that the reservoir be located below the level of the head of the cylinder.

On 1.50" bore with 0.625" rod the drain port is located in the head adjacent to the port. The retainer thickness

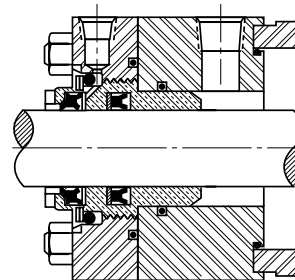

on 1.50" bore with 1.000" rod and bushing drain is increased to 0.63". On 2.00"-8.00" bore sizes the drain port is located in the retainer as shown. On Style JJ with bushing drain, the drain port is in the head.

**Air Bleeds**

In most hydraulic circuits, cylinders are considered self-bleeding when cycled full stroke. If air bleeds are required and specified, 1/8" NPTF Air Bleed Ports for venting air can be provided at both ends of the cylinder body, or on the head or cap. To order, specify "Bleed Port", and indicate position desired.

Engineering Data



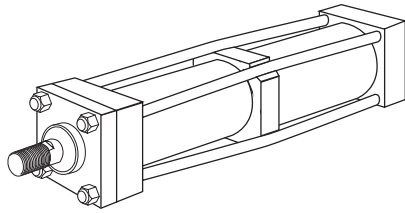

**Tie Rod Supports**

**Rigidity of Envelope** – Atlas heavy duty hydraulic cylinders have advantages in rigidity within the limits of the cylinder tube to resist buckling. For long stroke tie rod cylinders, within practical limits, Atlas provides Tie Rod Supports (see table below) that move the tie rod centerlines radially outward.

Standard tie rod supports are kept within the envelope dimensions of the head and cap, and generally do not interfere with mounting a long cylinder.

Number of Supports Required	Bore Ø	Stroke (Inches)											
		36	48	60	72	84	96	108	120	132	144	156	168
1.50	—	—	1	1	2	2	2	3	3	3	4		
2.00	—	—	1	1	1	2	2	2	2	3	3		
2.50	—	—	—	—	1	1	1	1	1	1	2	2	
3.25	—	—	—	—	—	—	—	1	1	1	1	1	
4.00	—	—	—	—	—	—	—	—	—	1	1	1	

Note: 5.00" through 14.00" bore sizes — no supports required.

**Stroke Adjusters**

For the requirement where adjusting the stroke is specified. Atlas has several designs to offer, one of which is illustrated below. This is suitable for infrequent adjustment and is economical<sup>1</sup>.

Bore Ø	D	J	K	L (Max.)
1.50	1/2 - 20	0.31	0.94	5
2.00	3/4 - 16	0.44	1.25	8
2.50, 3.25	1 - 14	0.63	1.69	9
4.00	1 1/2 - 12	0.94	2.13	18
5.00	2 - 12	0.94	2.69	20
6.00	2 1/2 - 12	1.69	3.13	20
7.00	3 - 12	2.00	3.25	20
8.00	3 1/2 - 12	2.38	3.50	20

Here a “retracting stroke adjuster” must be called for in specifications, and the length of the adjustment must be specified.

Where frequent adjustment or cushions at the cap end are required, other designs are available according to application needs.

<sup>1</sup> Infrequent is defined by positioning the retract stroke in a couple of attempts at original machine set up. The frequent stroke adjuster is recommended for adjustments required after the original equipment has been adjusted by the original machine manufacturer.

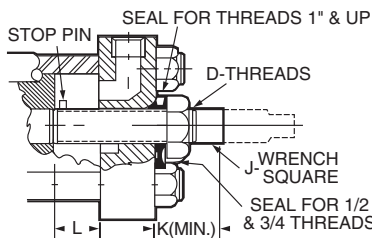

**Thrust Key Mountings**

Thrust key mountings eliminate the need of using fitted bolts or external keys on side mounted cylinders. Atlas cylinders in mounting styles CP and FP can be provided with the bushing retainer plate extended below the mounting side of the cylinder (see illustration below). This extended retainer plate can then be fitted into a keyway milled into the mounting surface of the machine member. This is referred to as the “P” Modification of any side mounting style.

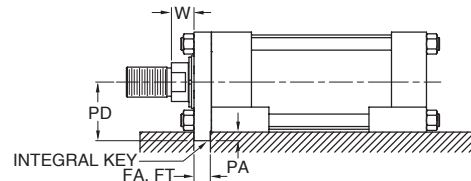

Bore Ø	FA	FT	PA	PD Mtg. Styles CP & FP
1.50	.361 -0.001 +0.000	.312 -0.002 +0.000	0.19	1.44
2.00	.611 -0.001 +0.000	.562 -0.002 +0.000	0.31	1.81
2.50	.611 -0.001 +0.000	.562 -0.002 +0.000	0.31	2.06
3.25	.736 -0.001 +0.000	.687 -0.003 +0.000	0.38	2.63
4.00	.861 -0.001 +0.000	.812 -0.003 +0.000	0.44	2.94
5.00	.861 -0.001 +0.000	.812 -0.003 +0.000	0.44	3.69
6.00	.986 -0.001 +0.000	.937 -0.003 +0.000	0.50	4.25
7.00	.986 -0.001 +0.000	.937 -0.003 +0.000	0.50	4.75
8.00	.986 -0.001 +0.000	.937 -0.003 +0.000	0.50	5.25

**Metric Piston Rod Thread**

The table below lists the standard thread supplied when Piston Rod Thread type M is specified in the cylinder model code.

MM Rod Ø	Thread		A
	Style 8M CC	Styles 4M & 9M KK	
0.625	M12x1.5	M10x1.5	0.75
1.000	M22x1.5	M20x1.5	1.13
1.375	M30x2	M26x1.5	1.63
1.750	M39x2	M33x2	2.00
2.000	M45x2	M39x2	2.25
2.500	M56x2	M48x2	3.00
3.000	M68x2	M58x2	3.50
3.500	M76x2	M64x2	3.50
4.000	M95x2	M76x2	4.00
4.500	M110x2	M80x2	4.50
5.000	M110x2	M90x2	5.00
5.500	M130x2	M100x2	5.50
7.000	-	M125x4	7.00
8.000	-	M140x4	8.00
9.000	-	M160x4	9.00
10.000	-	M180x4	10.00

**Theoretical Push Forces for Hydraulic Cylinders**

Cylinder Bore Ø	Piston Area (Sq. In.)	Cylinder Push Stroke Force in Pounds at Various Pressures						
		100	250	500	1000	1500	2000	3000
1.50	1.77	177	443	885	1770	2651	3540	5310
2.00	3.14	314	785	1570	3140	4712	6280	9420
2.50	4.91	491	1228	2455	4910	7363	9820	14730
3.25	8.30	830	2075	4150	8300	12444	16600	24900
4.00	12.57	1257	3143	6285	12570	18850	25140	37710
5.00	19.64	1964	4910	9820	19640	29453	39280	58920
6.00	28.27	2827	7068	14135	28270	42412	56540	84810
7.00	38.49	3849	9623	19245	38490	57727	76980	115470
8.00	50.27	5027	12568	25135	50270	75398	100540	150810
10.00	78.54	7854	19635	39270	78540	117810	157080	235620
12.00	113.10	11310	28275	56550	113100	169650	226200	339300
14.00	153.94	15394	38485	76970	153940	230910	307880	461820
16.00	201.06	20106	50265	100530	201060	301590	402120	603180
18.00	254.47	25447	63620	127230	254470	381700	508940	763410
20.00	314.16	31416	78540	157080	314160	471240	628320	942480

**General Formula**

The cylinder output forces are derived from the formula:

$$F = P \times A$$

Where F = Force in pounds.

P = Pressure at the cylinder in pounds per square inch, gauge.

A = Effective area of cylinder piston in square inches.

**Pull Forces**

**Theoretical Pull Forces for Hydraulic Cylinders**

Cylinder Bore Ø	Piston Rod Ø	Piston Rod Area (Sq. In.)	Cylinder Pull Force in Pounds at Various Pressures (psi)						
			100	250	500	1000	1500	2000	3000
1.50	0.625	0.307	146	365	730	1460	2190	2920	4380
	1.000	0.785	98	245	491	982	1473	1964	2946
2.00	1.000	0.785	236	589	1178	2355	3533	4710	7065
	1.375	1.48	166	414	828	1655	2483	3310	4965
2.50	1.000	0.785	413	1031	2063	4125	6188	8250	12375
	1.375	1.48	343	856	1713	3425	5138	6850	10275
	1.750	2.41	250	625	1250	2500	3750	5000	7500
3.25	1.375	1.48	682	1704	3408	6815	10223	13630	20445
	1.750	2.41	589	1473	2945	5890	8835	11780	17670
	2.000	3.14	516	1290	2580	5160	7740	10320	15480
4.00	1.750	2.41	1016	2540	5080	10160	15240	20320	30480
	2.000	3.14	943	2358	4715	9430	14145	18860	28290
	2.500	4.91	766	1915	3830	7660	11490	15320	22980
5.00	2.000	3.14	1650	4125	8250	16500	24750	33000	49500
	2.500	4.91	1473	3683	7365	14730	22095	29460	44190
	3.000	7.07	1257	3143	6285	12570	18855	25140	37710
	3.500	9.62	1002	2505	5010	10020	15030	20040	30060
6.00	2.500	4.91	2336	5840	11680	23360	35040	46720	70080
	3.000	7.07	2120	5300	10600	21200	31800	42400	63600
	3.500	9.62	1865	4663	9325	18650	27975	37300	55950
	4.000	12.57	1570	3925	7850	15700	23550	31400	47100
7.00	3.000	7.07	3142	7855	15710	31420	47130	62840	94260
	3.500	9.62	2887	7218	14435	28870	43305	57740	86610
	4.000	12.57	2592	6480	12960	25920	38880	51840	77760
	4.500	15.90	2259	5648	11295	22590	33885	45180	67770
	5.000	19.63	1886	4715	9430	18860	28290	37720	56580
8.00	3.500	9.62	4065	10163	20325	40650	60975	81300	121950
	4.000	12.57	3770	9425	18850	37700	56550	75400	113100
	4.500	15.90	3437	8593	17185	34370	51555	68740	103110
	5.000	19.63	3064	7660	15320	30640	45960	61280	91920
	5.500	23.76	2651	6628	13255	26510	39765	53020	79530
10.00	4.500	15.90	6264	15660	31320	62640	93960	125280	187920
	5.000	19.63	5891	14728	29455	58910	88365	117820	176730
	5.500	23.76	5478	13695	27390	54780	82170	109560	164340
	7.000	38.48	4006	10015	20030	40060	60090	80120	120180
12.00	5.500	23.76	8934	22335	44670	89340	134010	178680	268020
	7.000	38.48	7462	18655	37310	74620	111930	149240	223860
	8.000	50.26	6284	15710	31420	62840	94260	125680	188520
14.00	7.000	38.48	11546	28865	57730	115460	173190	230920	346380
	8.000	50.26	10368	25920	51840	103680	155520	207360	311040
	10.000	78.54	7540	18850	37700	75400	113100	150800	226200
16.00	8.000	50.26	15080	37700	75400	150800	226200	301600	452400
	9.000	63.62	13744	34360	68720	137440	206160	274880	412320
	10.000	78.54	12252	30630	61260	122520	183780	245040	367560
18.00	9.000	63.62	19085	47713	95425	190850	286275	381700	572550
	10.000	78.54	17593	43983	87965	175930	263895	351860	527790
20.00	10.000	78.54	23562	58905	117810	235620	353430	471240	706860



## Global Shield™ Rod Coating Technology

### A Dramatically Different Approach to Resisting Corrosion

Atlas's **Global Shield** rod coating technology is specifically designed to address corrosion resistance requirements of challenging industrial applications. When compared to traditional rod coatings, **Global Shield** has the following advantages:

- **Significantly Improved Corrosion Resistance** from the single-layer, fully dense, submicron structure and the lack of micro cracks inherent to chrome plating.
- **Lower Friction**
- **Ductile and Tough** so when the rod bends, it does too
- **Engineered Hardness** (HRC 54 minimum) for wear-resistance

The **value** that you will receive from **Global Shield** includes:

- **Less Downtime** from reduced maintenance intervals (cylinder repairs and seal replacements)
- **Longer Seal Life** in corrosive environments
- **Lower Service Costs** since you won't need to replace the piston rod due to corrosion

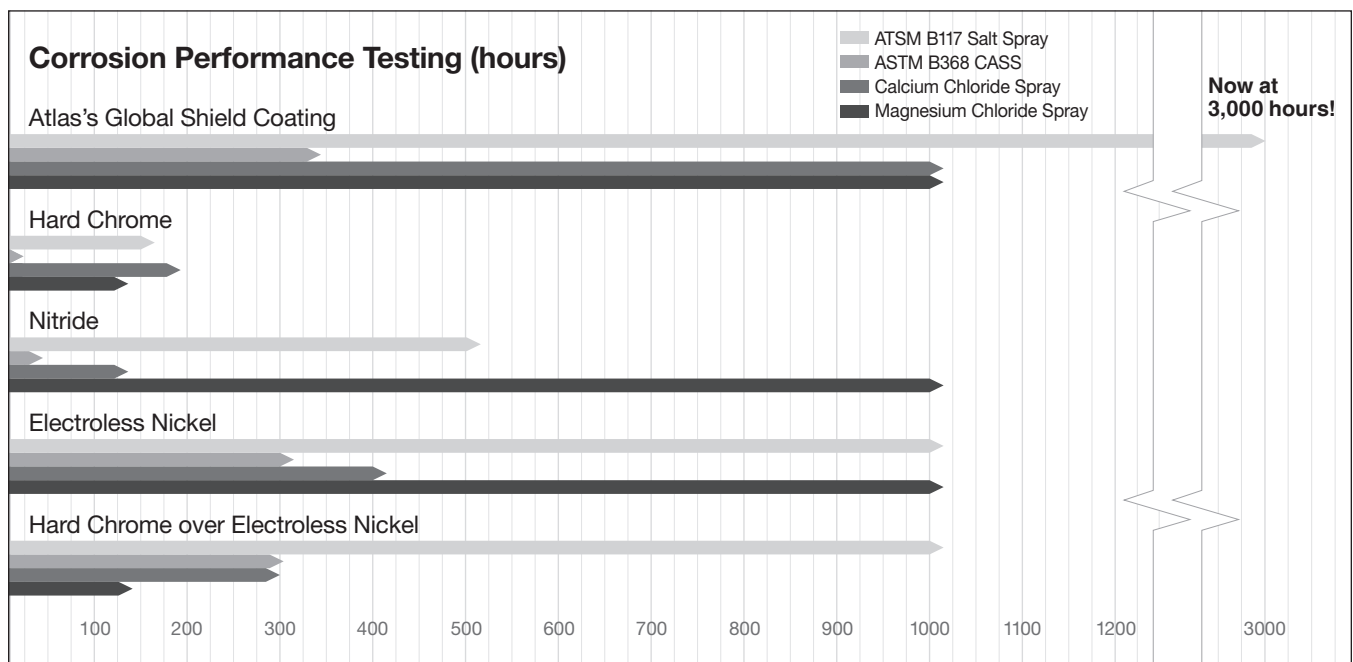

### Performance Validated in the Lab and in the field

This breakthrough proprietary technology, owned and manufactured by Parker Hannifin Corporation, has been thoroughly tested in the lab and in the field to validate performance in the areas of corrosion and dynamic wear resistance. Cylinders protected with Atlas's Global Shield

coating have demonstrated resistance to corrosion up to 8x longer than conventional coatings. Tests also confirm leak-free performance even after 1 million cycles and 2,000 hours of salt spray.

### Availability

- Rod diameters from ½" to 15"
- Rod lengths to 13 feet
- Standard thickness – 0.001"  
*Up to 0.020" available; corrosion protection increases as the thickness increases*
- Standard substrate – 1045/1050 carbon steel  
*Other substrates available*

### How to Order

Enter an 'S' in the Special Modifications field of the model number and specify Global Shield Piston Rod Coating. Unless otherwise specified, standard 0.001" thickness will be supplied.

For additional Global Shield information see Bulletin HY08-0896.

**Cylinder Weights**

**Heavy Duty Hydraulic Cylinders  
H Series**

The weights shown below are for standard Series H hydraulic cylinders equipped with various diameter piston rods. To determine the net weights of a cylinder, first select the proper basic weight for zero stroke, then calculate the weight of the cylinder stroke and add the result to the basic weight. For extra rod extension use

piston rod weights per inch shown in Table C. Weights of cylinders with intermediate rods may be estimated from table below by taking the difference between the piston rod weights per inch and adding it to the Code 1 weight for the cylinder bore size involved.

**Table A** Cylinder Weights, in pounds, for Series H (7.00" & 8.00") hydraulic cylinders

Bore Ø	Rod Ø	Rod Code	Single Rod Cylinders Basic Weight Zero Stroke		Add Per Inch of Stroke	Double Rod Cylinders Basic Weight Zero Stroke		Add Per Inch of Stroke
			F, H, HB, J, JB T, TB, TC, TD	BB, C, D, DB, DD, DE, HH, JJ, SB, SE		KF, KJ, KJB KT, KTB, KTD	KC, KD, KDD, KDE, KJJ	
1.50	0.625	1	7.8	9.0	0.5	9.7	10.8	0.6
	1.000	2	8.4	9.3	0.6	9.1	10.7	0.8
2.00	1.000	1	11.6	13.2	0.8	14.6	16.8	1.0
	1.375	2	13.5	17.1	1.0	19.4	20.6	1.4
2.50	1.000	1	17.0	19.5	1.1	21.0	24.5	1.3
	1.750	2	22.5	25.5	1.5	27.0	30.0	2.2
3.25	1.375	1	32.0	41.0	1.8	43.0	52.0	2.2
	2.000	2	37.0	46.0	2.2	48.0	57.0	3.1
4.00	1.750	1	48.0	53.0	2.5	59.0	63.0	3.2
	2.500	2	52.0	58.0	3.2	92.0	97.0	4.6
5.00	2.000	1	76.0	82.0	3.4	96.0	102.0	4.8
	3.500	2	88.0	86.0	5.2	117.0	123.0	7.9
6.00	2.500	1	125.0	133.0	5.2	153.0	159.0	6.6
	4.000	2	133.0	140.0	7.3	182.0	190.0	10.9
7.00	3.000	1	233.0	242.0	6.7	320.0	339.0	8.7
	5.000	2	240.0	253.0	10.3	341.0	360.0	15.9
8.00	3.500	1	262.0	276.0	9.0	323.0	331.0	11.7
	5.500	2	300.0	309.0	13.0	390.0	411.0	19.7

**Table B** Cylinder Weights, in pounds, for Series H large bore hydraulic cylinders

Bore Ø	Rod Ø	Rod Code	Single Rod Cylinders Basic Weight Zero Stroke					Double Rod Cylinders	
			D, DB	DD, JJ, HH	JB, HB	BB, C	Add Per Inch of Stroke	Basic Weight Zero Stroke Add to All Mounting Styles	Add Per Inch of Stroke
10.00	4.500	1	562	646	684	607	15	43	20
	5.000	3	574	656	695	619	16	50	21
	5.500	4	583	667	705	628	17	64	24
	7.000	2	620	704	742	665	21	101	32
12.00	5.500	1	924	1057	1136	1000	22	64	29
	7.000	3	961	1094	1173	1036	26	101	37
	8.000	2	1022	1155	1234	1097	29	162	43
14.00	7.000	1	1335	1520	1582	1485	28	101	39
	8.000	3	1396	1581	1643	1546	31	162	45
	10.000	2	1496	1681	1743	1646	39	262	61

Bore Ø	Rod Ø	Rod Code	Single Rod Cylinders Basic Weight Zero Stroke				Double Rod Cylinders	
			JJ, HH	JB, HB	BB	Add Per Inch of Stroke	Basic Weight Zero Stroke Add to All Mounting Styles	Add Per Inch of Stroke
16.00	8.000	1	2073	2257	2226	35	149	49
	9.000	3	2122	2305	2275	39	198	57
	10.000	4	2181	2364	2334	43	257	65
18.00	9.000	1	3165	3256	3330	45	198	63
	10.000	3	3224	3315	3390	50	257	72
20.00	10.000	1	4231	4406	4551	57	257	79

**Table C** Extra weight for longer than standard rod extensions can be calculated from the table below.

Rod Ø	Piston Rod Weight Per Inch	Rod Ø	Piston Rod Weight Per Inch	Rod Ø	Piston Rod Weight Per Inch
0.625	0.09	2.500	1.40	5.000	5.56
1.000	0.22	3.000	2.00	5.500	6.72
1.375	0.42	3.500	2.72	7.000	10.89
1.750	0.68	4.000	3.56	8.000	14.22
2.000	0.89	4.500	4.51	10.000	22.23

**Operating Fluids and Temperature Range**

Fluidpower cylinders are designed for use with pressurized air, hydraulic oil and fire resistant fluids, in some cases special seals are required.

**Class 1 – Standard Seals**

Class 1 seals are intended for use with fluids such as: air, nitrogen, mineral base hydraulic oil or MIL-H-5606 within the temperature range of -10°F (-23°C) to +165°F (+74°C). Generally they are nitrile except for piston rod seals in hydraulic cylinders. However the individual seals may be nitrile (Buna-N) enhanced polyurethane, polymyte, PTFE or filled PTFE.

**Class 2 – Water Base Fluid Seals**

Generally class 2 seals are intended for use with water base fluids within the temperature of -10°F (-23°C) to +165°F (+74°C) except for High Water Content Fluids (HWCF) in which case Class 6 seals should be used. Typical water base fluids are: Water, Water-Glycol, Water-in-Oil Emulsion, Houghton-Safe 27, 620, 5040, Mobil Pyrogard D, Shell Iruis 905, Ucon Hydrolube J-4. These seals are nitrile.

**Class 3 – Ethylene Propylene (EPR) Seals**

Class 3 seals are intended for use with some Phosphate Ester Fluids between the temperatures of -10°F (-23°C) to +130°F (+54°C). Typical fluids compatible with EPR seals are Skydrol 500 and 700. EPR are Ethylene Propylene. Note: EPR seals are not compatible with mineral base hydraulic oil or greases. Even limited exposure to these fluids will cause severe swelling.

**Class 4 – Low Temperature Nitrile Seals**

Class 4 seals are intended for low temperature service with the same type of fluids as used with Class 1 seals within the temperature range of -50°F (-46°C) to +150°F (+66°C). Note: Certain fluids may react adversely with Class 4 seals compared to Class 1 seals.

**Class 5 – Fluorocarbon (FKM) Seals**

Class 5 seals are intended for elevated temperature service or for some Phosphate Ester Fluids such as Houghton-Safe 1010, 1055, 1120; Fyrquel 150, 220, 300, 350; Mobile Pyrogard 42, 43, 53, and 55. However, they are not compatible with Phosphate Ester Fluids such as Skydrols. Class 5 seals can operate with a temperature range of -10°F (-23°C) to +300°F (+149°C). For temperatures above +250°F (+121°C) the cylinder must be manufactured with non-studded piston rod and thread and a pinned piston to rod connection.

**Class E – Fluorocarbon piston rod bushing seals only**

Intended for applications where only the rod bushing is exposed to fluids or temperatures needing fluorocarbon compatibility.

**Class 6 – HWCF Seals**

Class 6 seals are intended for High Water Content Fluids (HWCF) such as Houghton, Hydrolubric 120B and Sonsol Lubrizol within the

temperature range of +40°F (+4°C) to +120°F (+49°C). Class 6 seals are special nitrile compound dynamic seals. Because of the viscosity of these fluids, cylinders specified with class 6 seals, will also be modified to have straight cushions.

**Class 8 – High Temperature Seals**

Class 8 seals consist of filled PTFE piston seal, rod seals and wiperseal. They are intended for high temperature applications, to 400° F (204° C), where longer seal life and improved high temperature sealing performance is required. Minimum operating temperature is -15°F (-26°C). Body and bushing o-ring seals will be fluorocarbon. Fluid resistance is comparable to Class 5. Cylinders incorporating Class 8 Seals will not have studded piston rods.

**Class N – Class 8 piston rod bushing seals only – all other seals are fluorocarbon** Intended for applications where only the rod bushing is exposed to fluids or temperatures needing filled PTFE seal compatibility.

**Warning** ⚠

The piston rod stud and the piston rod to piston threaded connections are secured with an anaerobic adhesive which is temperature sensitive. Cylinders are assembled with anaerobic adhesive having a maximum temperature rating of +250°F (+121°C). Cylinders specified with all other seal compounds (built before 1997) were assembled with anaerobic adhesive having a maximum operating temperature rating +165°F (+74°C). These temperature limitations are necessary to prevent the possible loosening of the threaded connections. Cylinders originally manufactured (before 1997) with class 1 seals (Nitrile) that will be exposed to ambient temperatures above +165°F (+74°C) must be modified for higher temperature service. Contact the factory immediately and arrange for the piston to rod and the stud to piston rod connections to be properly re-assembled to withstand the higher temperature service.

**Water Service**

Series H cylinders can be modified to make them more suitable for use with water as the operating medium. The modifications include chrome-plated cylinder bore; electroless nickel-plated head, cap and piston; chrome-plated 17-4 stainless steel piston rod; chrome plated cushion sleeve or cushion spear. Water and high water base fluid operated cylinders are best used on short stroke applications or where high pressure is applied only to clamp the load.

**Warranty**

Parker Hannifin will warrant cylinders modified for water or high water content fluid service to be free of defects in materials or workmanship, but cannot accept responsibility to premature failure due to excessive wear due to lack of lubricity or where failure is caused by corrosion, electrolysis or mineral deposits within the cylinder.

**Seal Materials & Piston Seal Availability by Seal Class**

Seal Code (Class)	Description	Bushing Codes A, H & K			Piston Wear Rings	Piston Seal Material & Availability by Type				Piston Seal Energizer <sup>1</sup>	Piston Joint O-Ring	Body End Seals	Seal Back-Up Washer (If required)
		Rod Wiper-seal	Rod Seal	Bushing O-Ring		HP Urethane	KP Filled PTFE	RP Thermo-plastic	WP Filled PTFE				
1	Standard Seals	Urethane	Urethane	Urethane	WearGard™	Yes	Yes	Yes	Yes	Nitrile	Urethane	Urethane	PTFE
2	Water Base Fluid Seals	Nitrile	Nitrile	Nitrile	Polyester Resin/Fabric	No	Yes	Yes	Yes	Nitrile	Nitrile	Nitrile	PTFE
3	EPR Seals	EPR	EPR	EPR	WearGard™	No	Yes	Yes	Yes	EPR	EPR	EPR	PTFE
4	Low Temp. Nitrile Seals	Nitrile	Nitrile	Nitrile	WearGard™	Yes	Yes	Yes	No	Nitrile	Nitrile	Nitrile	PTFE
5	Fluorocarbon Seals	FKM	FKM	FKM	WearGard™	No	Yes	Yes	Yes	FKM	FKM	FKM	PTFE
6	HWCF Seals	Nitrile	Nitrile	Nitrile	Polyester Resin/Fabric	No	Yes	Yes	Yes	Nitrile	Nitrile	Nitrile	PTFE
8	High Temp. Seals	Filled PTFE	Filled PTFE	FKM	HT Resin/ Aramid	No	Yes	No	No	FKM	FKM	FKM	PTFE
E	Fluorocarbon Bushing Seals	FKM	FKM	FKM	WearGard™	Yes	Yes	Yes	Yes	FKM	FKM	FKM	PTFE
N	High Temp. Bushing Seals	Filled PTFE	Filled PTFE	FKM	HT Resin/ Aramid	Yes	Yes	Yes	Yes	FKM	FKM	FKM	PTFE

<sup>1</sup> Includes material of redundant quad ring seal for Atlas WP Mixed Media Seal



## Fluids and Temperature Range

Class No.	Typical Fluids	Temperature Range
1 (Standard) (Nitrile Polyurethane)	Air, Nitrogen Hydraulic Oil, Mil-H-5606 Oil	-10°F (-23°C) to +165°F (+74°C)
2 Optional Water Base Fluid Seal	Water, Water-Glycol, HWCF — See Class 6 below. Water-in-Oil Emulsion Houghto-Safe, 271, 620, 5040. Mobil Pyrogard D, Shell Iru 905. Ucon Hydrolube J-4	-10°F (-23°C) to +165°F (+74°C)
3 Special (EPR) (at extra cost)	Some Phosphate Ester Fluids Skydrol 500, 7000	-10°F (-23°C) to +130°F (+54°C)
Note: (EPR) seals are not compatible with Hydraulic Oil		
4 Special (Nitrile) (at extra cost)	Low Temperature Air or Hydraulic Oil	-50°F (-46°C) to +150°F (+66°C)
5 Optional (at extra cost) (Fluorocarbon Seals)	High Temperature Houghto-Safe 1010, 1055, 1120 Fyrquel 150, 220, 300, 550 Mobil Pyrogard 42,43,53,55	See paragraph on Fluorocarbon seals for recommended temperature range.
Note: Fluorocarbon seals are not suitable for use with Skydrol fluid, but can be used with hydraulic oil if desired.		
6 Optional (HWCF) (at extra cost)	Houghton, Hydrolubric 120B Sonsol Lubrizol, for other HWCF — consult factory.	+40°F (+4°C) to +120°F (+49°C)
8 Optional (at extra cost) Energized PTFE	See Class 5 Seals	-15°F (-26°C) to +400°F (+204°C)

## Application Data

The proper application of a fluid power cylinder requires consideration of the operating pressure, the fluid medium, the mounting style, the length of stroke, the type of piston rod connection to the load, thrust or

tension loading on the rod, mounting attitude, the speed of stroke, and how the load in motion will be stopped. Information given here provides pressure rating data for hydraulic cylinders.

## Pressure Ratings

Standard operating fluid — clean, filtered hydraulic oil. Pressure ratings for heavy-duty hydraulic cylinders are shown in the table.

Series H hydraulic cylinders are recommended for pressures to 3000 psi for heavy-duty service with hydraulic oil. The 4:1 design factor ratings shown are based on tensile strength of material and are for standard rod diameter only. The rating is conservative for continuous severe applications. Design factors at other pressures can be calculated from this rating. In addition, mounting styles, stroke, etc., should be considered because of the limiting effect they may have on these ratings.

Series H Hydraulic Cylinders  
Maximum Pressure Ratings

Bore Ø	Rod Ø	4:1 <sup>1</sup> Design Factor (Tensile) (psi)	Heavy-Duty Service (psi)
1.50	0.625	2530	3000
2.00	1.000	2950	3000
2.50	1.000	2340	3000
3.25	1.375	2250	3000
4.00	1.750	2130	3000
5.00	2.000	2170	3000
6.00	2.500	2270	3000
7.00	3.000	2030	3000
8.00	3.500	2040	3000
10.00	4.500	2720	3000
12.00	5.500	2580	3000
14.00	7.000	2320	3000
16.00	8.000	2750	3000
18.00	9.000	2900	3000
20.00	10.000	2640	3000

<sup>1</sup> Applies to all mountings except Styles J, JB and H.

**Piston Friction**

Atlas's new universal piston design provides not only superior sealing and wear performance, but also conserves operating energy with reduced running friction when compared to traditional sealing technologies. Running friction test results for the most

popular seal configurations, HP Polyurethane Piston Seal and KP filled PTFE Piston Seal in 2.00", 4.00", 6.00" and 8.00" bores are shown in graphs below. Friction for intermediate bore sizes can be estimated using curves for bore sizes tested.

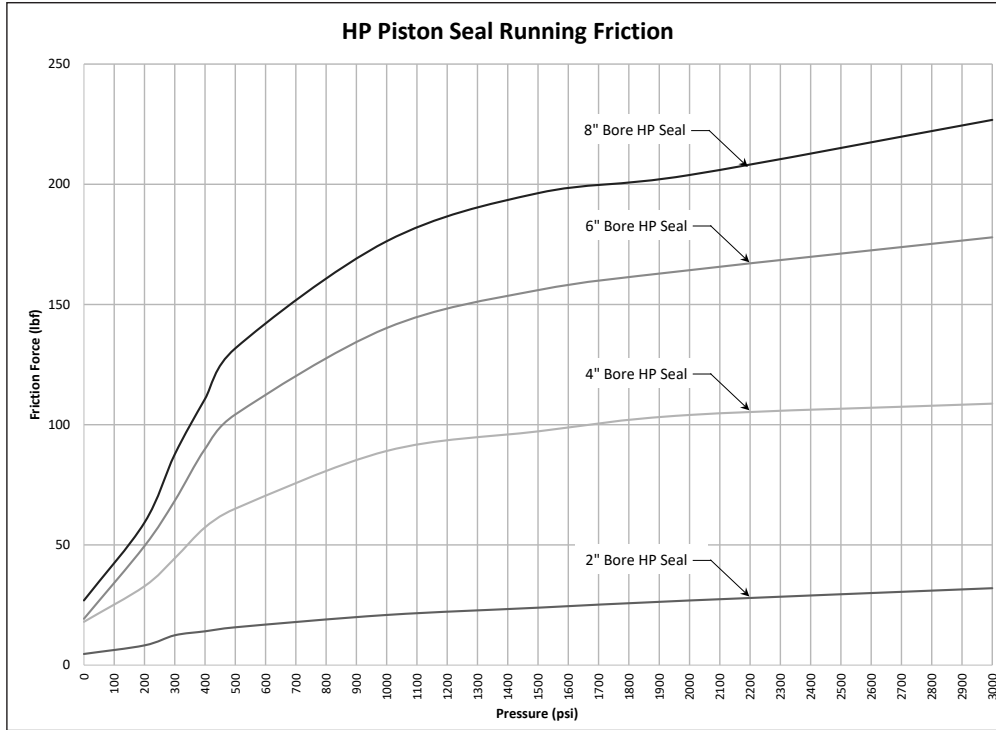

**Atlas HP Polyurethane Piston Seal**

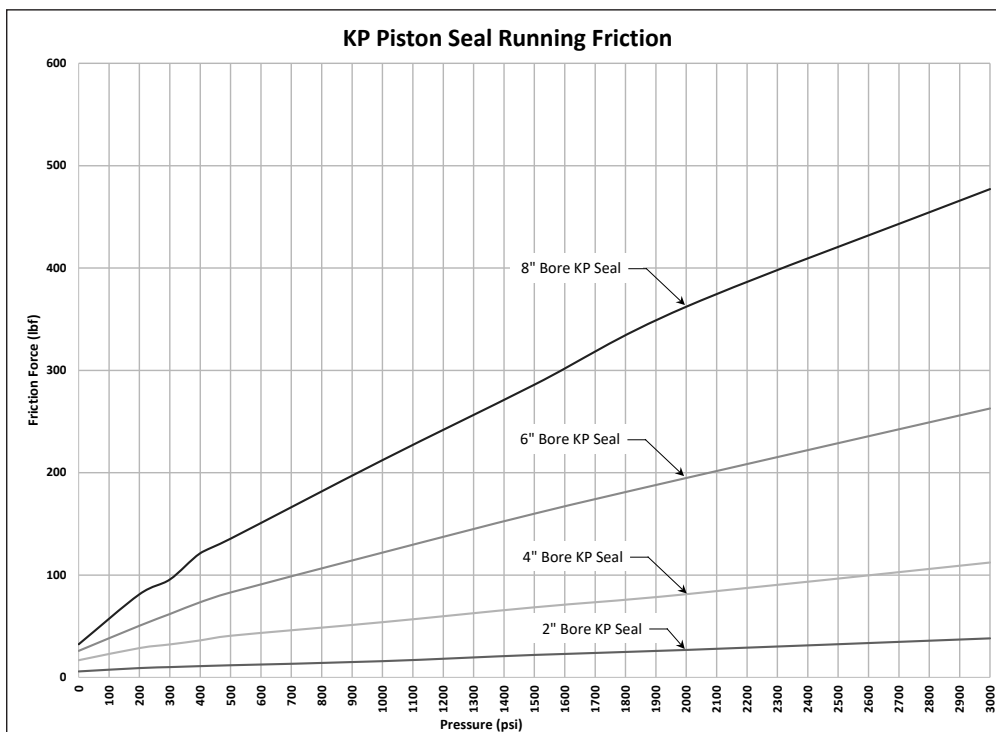
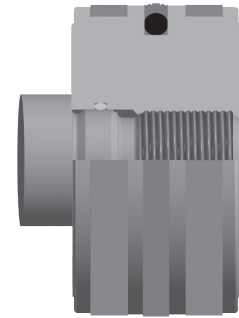

**Atlas KP Filled PTFE Piston Seal**

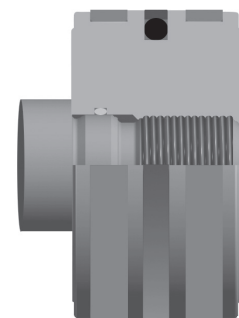

**Bushing Friction**

Bushing friction is also a factor in cylinder operating efficiency and combined with piston seal friction will yield an overall cylinder running friction value. Running friction test results for H (Tri-Lip) and Low Friction bushings in

1.000", 1.750", 2.500" and 5.000" piston rod diameters are shown in the graphs below. Friction for intermediate rod diameters can be estimated using curves for bore sizes tested.

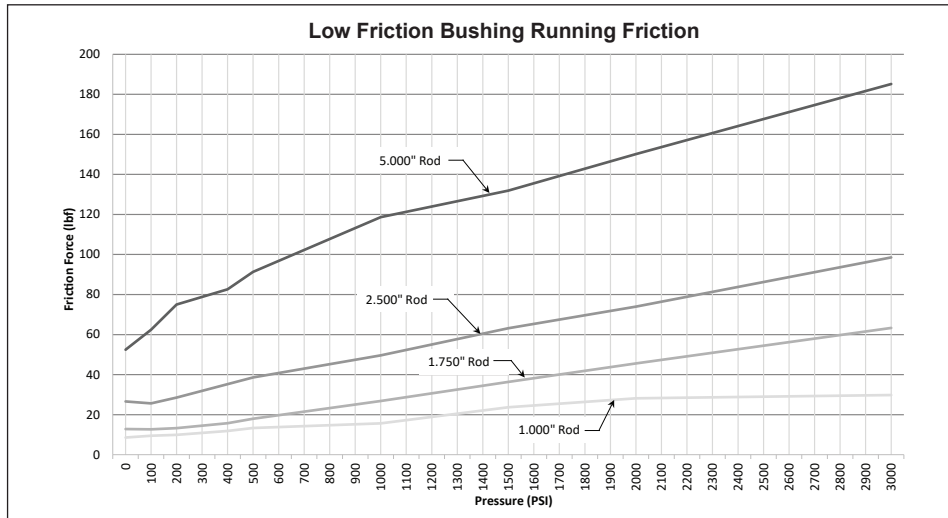
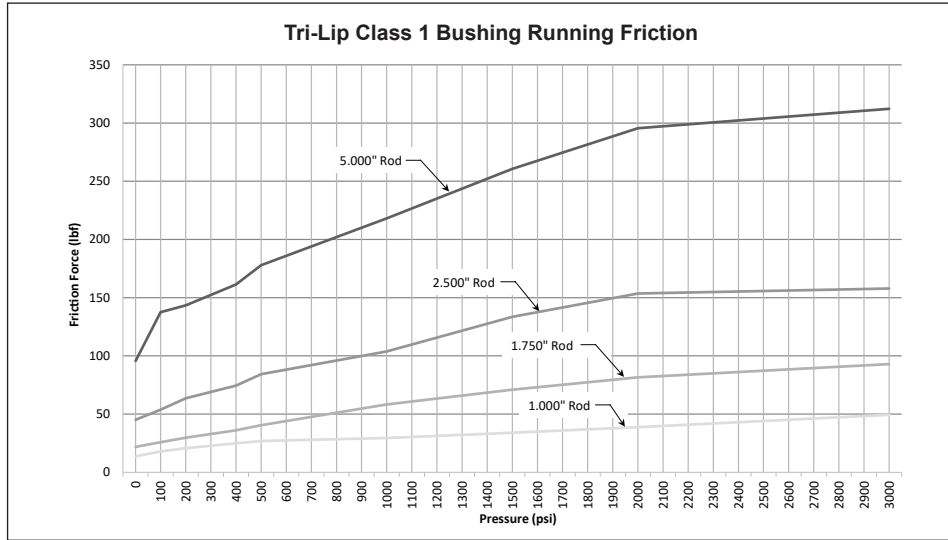

**Piston Orifice**

Atlas's RP Thermoplastic piston seal is fully extrusion resistant and the choice for applications formerly served by cast iron rings. For some applications, cast iron rings are selected because of the inherent piston bypass. Where bypass is required for the RP seal (or any other universal piston seal style), a piston orifice option is available. There are three orifice diameters to choose from, 0.016", 0.024" and 0.032". Flow charts at right detail the bypass flow at various pressures for each orifice. Specify the orifice by placing an 'S' in the Special Modification field of the model number and describe the orifice as in the following example: S = 0.024" Piston Orifice (insert desired orifice dia). Piston orifice not available in bores 1.50", 2.00" and 2.50" with rod codes 2 & 3.

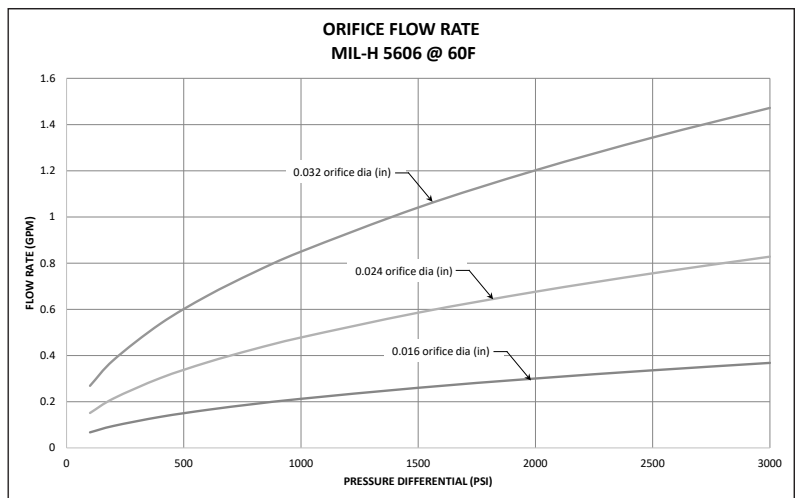

Engineering Data

Ports

Ports

Series H cylinders can be supplied with SAE straight O-ring ports or NPTF pipe thread ports. If specified on your order, extra ports can be provided on the sides of heads or caps that are not occupied by mountings or cushion valve.

Standard port location is position 1 as shown on line drawings in product catalog and Figure 1 below. Cushion adjustment needle and check valves are at positions 2 and 4 (or 3), depending on mounting style. Heads or caps which do not have an integral mounting can be rotated and assembled with ports at 90° or 180° from standard position. Mounting styles on which head or cap can be rotated at no extra charge are shown in Table A below. To order, specify by position number. In such assemblies the cushion adjustment needle and check valve rotate accordingly since their relationship with port position does not change.

Figure 1

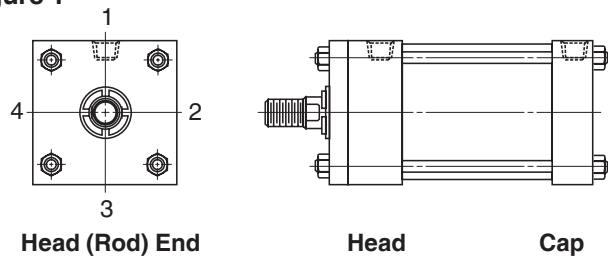

Table A

Mounting Style	Port Position Available	
	Head End	Cap End
TB, TC, TD, J, H, JB, HB, DD, DE	1, 2, 3 or 4	1, 2, 3 or 4
HH, DB, BB, SB, SE	1, 2, 3 or 4	1 or 3
JJ, D	1 or 3	1, 2, 3 or 4
C, F	1	1

Ports can be supplied at positions other than those shown in Table A at an extra charge. To order, specify port position as shown in Figure 1.

Straight Thread Ports

The SAE straight thread O-ring port is recommended for hydraulic applications. Atlas will furnish this port configuration at positions shown in Table A. This port can also be provided at positions other than those shown in Table A at an extra charge. SAE port size numbers are listed next to the NPTF pipe thread counterparts for each bore size in the respective product catalogs. Size number, tube O.D., and port thread size for SAE ports are listed in Table B.

Table B — SAE Straight Thread O-Ring Ports

Size No.	Tube O.D. (In.)	Thread Size	Size No.	Tube O.D. (In.)	Thread Size
2	0.13	5/16 - 24	12	0.75	1 1/16 - 12
3	0.19	3/8 - 24	—	—	—
4	0.25	7/16 - 20	16	1.00	1 5/16 - 12
5	0.31	1/2 - 20	20	1.25	1 5/8 - 12
6	0.38	9/16 - 18	24	1.50	1 7/8 - 12
8	0.50	3/4 - 16	32	2.00	2 1/2 - 12
10	0.63	7/8 - 14	—	—	—

**Note:** For the pressure ratings of individual connectors, contact your connector supplier. Hydraulic cylinders applied with meter out or deceleration circuits are subject to intensified pressure at the cylinder piston rod end. The rod end pressure is approximately equal to:

$$\frac{\text{Effective Cap End Piston Area}}{\text{Effective Rod End Piston Area}} \times \text{Operating Pressure}$$

International Ports

Other port configurations to meet international requirements are available at extra cost. Atlas Series H cylinders can be supplied, on request, with British standard taper port (BSPT). Such port has a taper of 1 in 16 measured on the diameter (1/16" per inch). The thread form is Whitworth System, and size and number of threads per inch are as follows:

Table C — British Standard Pipe Threads

Nominal Pipe Size	No. Threads Per Inch	Pipe O.D.
1/8	28	0.383
1/4	19	0.518
3/8	19	0.656
1/2	14	0.825
3/4	14	1.041
1	11	1.309
1 1/4	11	1.650
1 1/2	11	1.882
2	11	2.347

British standard parallel internal threads are designated as BSPP and have the same thread form and number of threads per inch as the BSPT type and can be supplied, on request, at extra cost. Unless otherwise specified, the BSPP or BSPT port size supplied will be the same nominal pipe size as the NPTF port for a given bore size cylinder.

Metric ports can also be supplied to order at extra cost. See table below for standard port size for each bore.

Table D – Standard Port Sizes

Bore Ø	T SAE	U NPTF	P SAE Code 61 Flange	Y ISO 6149	B BSPT R BSPP	G Metric
1.50	10	1/2	N/A	M22 x 1.5	1/2	M22 x 1.5
2.00	10	1/2	N/A	M22 x 1.5	1/2	M22 x 1.5
2.50	10	1/2	1/2 <sup>1</sup>	M22 x 1.5	1/2	M22 x 1.5
3.25	12	3/4	3/4	M27 x 2	3/4	M27 x 2
4.00	12	3/4	3/4	M27 x 2	3/4	M27 x 2
5.00	12	3/4	3/4	M27 x 2	3/4	M27 x 2
6.00	16	1	1	M33 x 2	1	M33 x 2

Bore Ø	T SAE	U NPTF	P SAE Code 61 Flange	Y ISO 6149	B BSPT R BSPP	G Metric
7.00	20	1 1/4	1 1/4	M42 x 2	1 1/4	M42 x 2
8.00	24	1 1/2	1 1/2	M48 x 2	1 1/2	M48 x 2
10.00	24	2	2	M48 x 2	2	M48 x 2
12.00	24	2 1/2	2 1/2	M48 x 2	2 1/2	M48 x 2
14.00	24	2 1/2	2 1/2	M48 x 2	2 1/2	M48 x 2
16.00-20.00	24	—	3	—	—	—

<sup>1</sup>Available with 1.000 inch rod diameter only.

Ports

Overize Ports

Overize NPTF or SAE straight thread ports can be provided, at an extra charge. For ports one size larger than standard, welded port bosses which protrude from the side of the head or cap are supplied. For dimensions, see drawings and tables below. Series H cylinders equipped with cushions at the cylinder cap end can sustain damage to the cushion check valve (cushion bushing) if excessive oil flow enters the cylinder from the cap end port. Cylinders which are equipped with cap end cushions and ordered with one size overize ports having hydraulic fluid velocity exceeding 25 ft./sec. in the line entering the cap end of the cylinder should be ordered with a "solid cushion" at cap end. All cylinders ordered with

double overize ports should always be ordered with a "solid cushion" at cap end.

Cylinders which are connected to a meter out flow control with flow entering the cap end of a cylinder provided by an accumulator may also experience damage to the cushion bushing due to high instantaneous fluid flows. This condition can be eliminated by using a meter in flow control or "solid cushions" at cap end.

Overize NPTF Port Boss Dimensions

Bore Ø	EE (NPTF)	A Ø	B	C	D	P
1.50	3/4	1.38	1.00	0.75	0.78	2.91
2.00	3/4	1.38	1.00	0.75	0.78	2.91
2.50	3/4	1.38	1.00	0.75	0.78	3.03
3.25	1	1.75	1.19	0.91	0.88	3.53
4.00	1	1.75	1.19	0.91	0.88	3.78
5.00	1	1.75	1.19	0.91	0.88	4.28
6.00	1 1/4	2.25	1.31	1.13	1.13	5.13
7.00	1 1/2	2.50	1.56	1.38	1.38	5.75
8.00	2	3.00	1.69	1.50	1.50	6.50

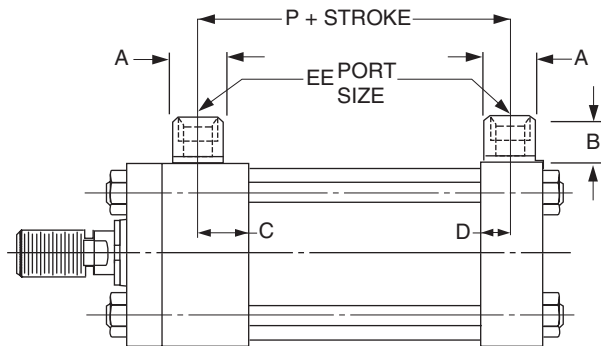

Overize SAE Straight Thread Port Boss Dimensions

Bore Ø	EE (SAE)	A Ø	B	C	D	P	
1.50	12 <sup>1</sup>	12	1.38	1.00	0.81	0.78	2.97
2.00	12 <sup>1</sup>	12	1.38	1.00	0.81	0.78	2.97
2.50	12 <sup>2</sup>	12 <sup>3</sup>	1.38	1.00	0.81	0.81	3.13
3.25	16	16	1.75	1.19	0.91	0.91	3.56
4.00	16	16	1.75	1.19	0.91	0.91	3.81
5.00	16	16	1.75	1.19	0.91	0.91	4.31
6.00	20 <sup>2</sup>	20 <sup>2</sup>	-	-	1.13	1.17	5.19
7.00	24 <sup>2</sup>	24 <sup>2</sup>	-	-	-	-	5.63
8.00	N/A	N/A	-	-	-	-	6.38

<sup>1</sup> Port tapped directly in head with code 1 rod these bores.

<sup>2</sup> Port tapped directly in head (all rod codes) and cap these bores.

<sup>3</sup> Port tapped directly in cap this bore.

Flange Ports (Code 61, 3000 psi) SAE 4 Bolt Flange Ports

Bore Ø	Rod No.	SAE Dash No.	A Ø	AA	GG	P	Q	W	X	Y	Z
2.50 <sup>4,5</sup>	1	8	.50	.81	.69	2.97	1.50	.75	.34	2.38	5/16 - 18
3.25 <sup>4</sup>	1	12	.75	.75	.87	3.47	1.87	.94	.44	2.75	3/8 - 16
	2									3.13	
	3									3.00	
4.00 <sup>4</sup>	1	12	.75	.75	.87	3.72	1.87	.94	.44	3.00	3/8 - 16
	2									3.38	
	3									3.13	
5.00 <sup>4</sup>	1	12	.75	.75	.87	4.22	1.87	.94	.44	3.13	3/8 - 16
	2									3.38	
	3									3.38	
	4									3.38	
6.00	All	16	1.00	.87	1.03	4.85	2.06	1.03	.52	3.50	3/8 - 16
7.00	All	20	1.25	1.00	1.19	5.47	2.31	1.16	.59	3.75	7/16 - 14
8.00	All	24	1.50	1.06	1.41	6.19	2.75	1.37	.70	3.88	1/2 - 13

<sup>4</sup> 2.50", 3.25", 4.00" & 5.00" bores cap-flange port not available on Style HB Style H not available at position 2 or 4. Port flange overhangs cap on Style HH.

<sup>5</sup> 2.50" bore head flange port available with 1.000" rod only.

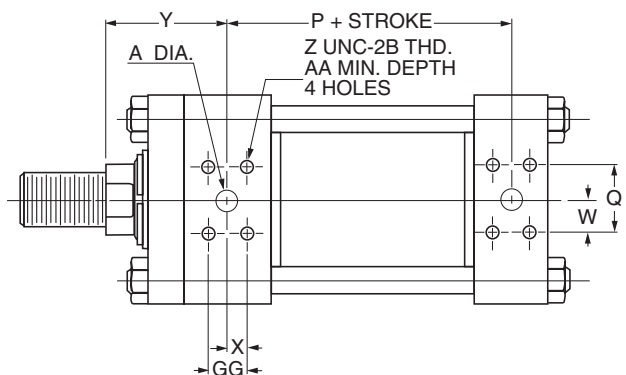

**Stroke Data**

Atlas cylinders are available in any practical stroke length. The following information should prove helpful to you in selecting the proper stroke for your cylinder application.

**Stroke Tolerances**

Stroke length tolerances are required due to buildup of tolerances of piston, head, cap and cylinder tube. Standard production of stroke tolerances run  $+0.031"$  to

$-0.015"$  up to 20" stroke,  $+0.031"$  to  $-0.020"$  for 21" to 60" and  $+0.031"$  to  $-0.031"$  for greater than 60" stroke. For closer tolerances on stroke length, it is necessary to specify the required tolerance plus the pressure and temperature at which the cylinder will operate. Stroke tolerances smaller than  $.015"$  are not generally practical due to elasticity of cylinders. If machine design requires such close tolerances, use of a stroke adjuster may achieve the desired result.

**Mounting Groups**

Standard mountings for fluid power cylinders fall into three basic groups. The groups can be summarized as follows:

**Group 1** Straight Line Force Transfer with fixed mounts which absorb force on cylinder centerline.

**Group 2** Pivot Force Transfer. Pivot mountings permit a cylinder to change its alignment in one plane.

**Group 3** Straight Line Force Transfer with fixed mounts which do not absorb force on cylinder centerline.

Because a cylinder's mounting directly affects the maximum pressure at which the cylinder can be used, the chart below should be helpful in selection of the proper mounting combination for your application. Stroke length, piston rod connection to load, extra piston rod length over standard, etc., should be considered for thrust loads. Alloy steel mounting bolts are recommended for all mounting styles, and thrust keys are recommended for Styles C and F.

**Double Rod End Cylinders**

The piston connection to rod #1 (without 'V' notch) of 1.50"-8.00" bore double rod end heavy duty hydraulic cylinders is pre-stressed for maximum fatigue life. For this reason the load should always be attached to the rod without 'V' notch. Extension rod #2 with 'V' notch is threaded to rod #1 and is recommended for non-load bearing attachment only.

For thrust (compression) load applications where the mounting style end of a double rod end cylinder is opposite the rod connected to the load it should be specified as a cap mounting style. For example, a head trunnion mounting style opposite the rod connected to the load should be specified as DB. This will ensure that the rod end without 'V' notch will be oriented opposite the head trunnion end. See the table below for guidance in selecting mounting styles that fit this criteria.

**Double Rod End Mounting Styles**

Mounting Styles for Single Rod Models	Mounting Styles for Corresponding Double Rod Models with the Load Connected To Rod Opposite Cylinder Mounting End
TB	KTC
J	KH
JB	KHB
JJ	KHH
D	KDB

**Double Rod Cylinder  
Style K**

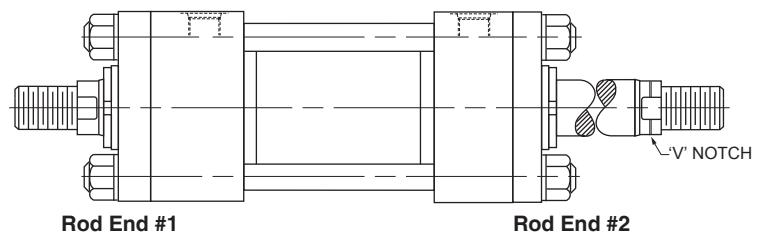

<b>Group 1 FIXED MOUNTS</b> which absorb force on cylinder centerline.	
<p><b>Heavy-Duty Service</b> For Thrust Loads For Tension Loads</p>	<p>Styles HB, HH, TC Styles JB, JJ, TB</p>
<p><b>Medium-Duty Service</b> For Thrust Loads For Tension Loads</p>	<p>Styles H, HB Styles J, JB</p>
<p><b>Light-Duty Service</b> For Thrust Loads For Tension Loads</p>	<p>Style H Style J</p>
<b>Group 2 PIVOT MOUNTS</b> which absorb force on cylinder centerline.	
<p><b>Heavy-Duty Service</b> For Thrust Loads For Tension Loads</p>	<p>Styles DD, D, DE, SE Styles BB, DD, D, DB, DE, SE</p>
<p><b>Medium-Duty Service</b> For Thrust Loads For Tension Loads</p>	<p>Styles BB, SB Styles BB, SB</p>
<b>Group 3 FIXED MOUNTS</b> which do not absorb force on the centerline.	
<p><b>Heavy-Duty Service</b> For Thrust Loads For Tension Loads</p>	<p>Styles C, CP Styles C, CP</p>
<p><b>Medium-Duty Service</b> For Thrust Loads For Tension Loads</p>	<p>Styles F, FP Styles F, FP</p>

Engineering Data



## Stop Tubing

### Stop Tubing

Stop tube is recommended to lengthen the distance between the rod bearing and piston bearing to reduce bearing loads on long push stroke cylinders when the cylinder is fully extended. This is especially true of horizontally mounted cylinders. As part of the piston assembly and positioned between the piston and head, a stop tube restricts the extended position of the rod using the increased distance to achieve additional stability.

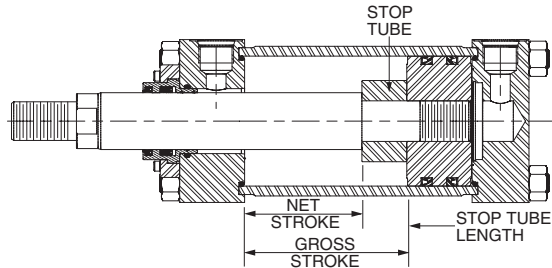

Use the following steps to determine the need for stop tube and, if required, how long it should be.

1. Examine the groups of cylinder illustrations below and determine which mounting and rod guiding group type match the required cylinder application.

## Heavy Duty Hydraulic Cylinders H Series

2. Establish the Basic Length (L), with the piston rod fully extended, for the selected illustration by using the dimensional tables on previous pages of this catalog. For pivot mounted cylinders, the pin-to-pin dimension with the piston rod fully extended must be used. Regardless of mounting style, be sure to include any extended piston rod length beyond the catalog standard.
3. In the Stop Tube Table select the column for the appropriate mounting style and rod end guiding type. In the Basic Length (L) column, find the row with the range that includes the value calculated in Step 2. The next respective column to the right has the required length of stop tube.

**Note:** Mounting Styles BB, DB, H, HB, HH, SB and SE are mounted horizontally should also be checked for turning moments and loads between the rod bearing and piston to ensure they are not excessive. Weight of oil must be included in determining bearing loads.

When specifying cylinders with stop tube be sure to call out the net stroke and the length of the stop tube. Machine design can be continued without delay by laying in a cylinder equivalent in length to the NET STROKE PLUS STOP TUBE LENGTH, which is referred to as GROSS STROKE.

### Stop Tube Length vs Basic Length (L)

Pivot Mounts (BB, D, DB, DD, DE, SB and SE)		Fixed Mounts (C, F, H, HB, HH, J, JB, JJ, TB, TC, TD)					
Pivoted and Rigidly Guided Rod End		Fixed & Rigidly Guided Rod End		Pivoted & Rigidly Guided Rod End		Unguided Rod End	
Basic Length (L)	Stop Tube Length	Basic Length (L)	Stop Tube Length	Basic Length (L)	Stop Tube Length	Basic Length (L)	Stop Tube Length
0 - 40	0	0 - 80	0	0 - 57	0	0 - 20	0
41 - 50	1	81 - 100	1	58 - 71	1	21 - 25	1
51 - 60	2	101 - 120	2	72 - 86	2	26 - 30	2
61 - 70	3	121 - 140	3	87 - 100	3	31 - 35	3
71 - 80	4	141 - 160	4	101 - 114	4	36 - 40	4
81 - 90	5	161 - 180	5	115 - 129	5	41 - 45	5
91 - 100	6	181 - 200	6	130 - 143	6	46 - 50	6
101 - 110	7	201 - 220	7	144 - 157	7	51 - 55	7
111 - 120	8	221 - 240	8	158 - 171	8	56 - 60	8
121 - 130	9	241 - 260	9	172 - 186	9	61 - 65	9
131 - 140	10	261 - 280	10	187 - 200	10	66 - 70	10
141 - 150	11	281 - 300	11	201 - 214	11	71 - 75	11
151 - 160	12			215 - 229	12	76 - 80	12
161 - 170	13			230 - 243	13	81 - 85	13
171 - 180	14			244 - 257	14	86 - 90	14
181 - 190	15			258 - 271	15	91 - 95	15
191 - 200	16			272 - 286	16	96 - 100	16
201 - 210	17			287 - 300	17	101 - 105	17
211 - 220	18					106 - 110	18
221 - 230	19					111 - 115	19
231 - 240	20					116 - 120	20
241 - 250	21					121 - 125	21
251 - 260	22					126 - 130	22
261 - 270	23					131 - 135	23
271 - 280	24					136 - 140	24
281 - 290	25					141 - 145	25
291 - 300	26					146 - 150	26
Consult Factory						Consult Factory	

### Cylinder Mounting and Rod Guiding Groups

Pivot Mount – Pivoted and rigidly guided rod end	
Styles BB, SB, SE	Styles DD, DE
Style D	Style DB
Fixed Mount – Fixed and rigidly guided rod end	
Styles J, JB, JJ	Styles H, HB, HH
Styles C, F	
Fixed Mount – Pivoted and rigidly guided rod end	
Styles J, JB, JJ	Styles H, HB, HH
Styles C, F	
Fixed Mount – Unguided rod end	
Styles J, JB, JJ	Styles H, HB, HH

**Piston Rod Diameter Selection**

Long stroke cylinders that work on push with the piston rod loaded in compression should be checked, using the following steps, to ensure an appropriate piston rod diameter is specified.

1. First, determine whether stop tubing is required as described on the previous page.
2. Use the Basic Length (L) that was established for determining the stop tube length and then add the required stop tube length to the Basic Length to obtain an Adjusted Basic Length (L<sub>A</sub>).
3. In the table below, for the mounting style and rod end guiding condition that will be used, find the row for the Bore and Rod combination that is required.
4. Follow the Bore and Rod row to the right and find the Operating Pressure column that is closest, but

5. If L<sub>A</sub> in the table is less than the calculated Adjusted Basic Length move down the column to a rod diameter with an L<sub>A</sub> that exceeds the requirement.
6. If the L<sub>A</sub> specifies a rod diameter in a larger bore then restart the process of sizing the stop tube and re-check the rod diameter. Contact the factory if L<sub>A</sub> exceeds 300 inches.

**Note:** Data in these tables assume standard rod extension (W or WF dimension) and standard rod end accessories. If different, consult factory.

**Maximum Basic Lengths (L<sub>A</sub>) (all dimensions in inches)**

Bore Ø	Rod Ø	Front and Side Fixed Mounts (J <sup>1</sup> , JB <sup>1</sup> , JJ, TB, TD, C, F)																		
		Fixed and Rigidly Guided Rod End Max. Allowable Basic Length (L <sub>A</sub> ) at psi:						Pivoted and Rigidly Guided Rod End Max. Allowable Basic Length (L <sub>A</sub> ) at psi:						Unguided Rod End Max. Allowable Basic Length (L <sub>A</sub> ) at psi:						
		500	1000	1500	2000	2500	3000	500	1000	1500	2000	2500	3000	500	1000	1500	2000	2500	3000	
1.50	0.625	50	35	29	25	22	20	36	25	21	18	16	15	13	9	7	6	6	5	
	1.000	128	91	74	64	57	52	92	65	53	46	41	37	32	23	19	16	14	13	
2.00	1.000	96	68	56	48	43	39	69	49	40	34	31	28	24	17	14	12	11	10	
	1.375	182	129	105	91	81	74	130	92	75	65	58	53	45	32	26	23	20	19	
2.50	1.000	77	54	44	38	34	31	55	39	32	27	25	22	19	14	11	10	9	8	
	1.375	146	103	84	73	65	59	104	73	60	52	46	42	36	26	21	18	16	15	
	1.750	236	167	136	118	105	96	168	119	97	84	75	69	59	42	34	29	26	24	
3.25	1.375	112	79	65	56	50	46	80	57	46	40	36	33	28	20	16	14	13	11	
	1.750	181	128	105	91	81	74	130	92	75	65	58	53	45	32	26	23	20	19	
	2.000	237	167	137	118	106	97	169	120	98	85	76	69	59	42	34	30	26	24	
4.00	1.750	147	104	85	74	66	60	105	74	61	53	47	43	37	26	21	18	16	15	
	2.000	192	136	111	96	86	79	137	97	79	69	61	56	48	34	28	24	22	20	
	2.500	300	213	174	150	134	123	215	152	124	107	96	88	75	53	43	38	34	31	
5.00	2.000	154	109	89	77	69	63	110	78	63	55	49	45	38	27	22	19	17	16	
	2.500	241	170	139	120	108	98	172	121	99	86	77	70	60	43	35	30	27	25	
	3.000	300	245	200	173	155	141	247	175	143	124	111	101	87	61	50	43	39	35	
6.00	3.500	300	300	272	236	211	192	300	238	194	168	151	137	118	83	68	59	53	48	
	2.500	200	142	116	100	90	82	143	101	83	72	64	58	50	35	29	25	22	20	
	3.000	289	204	167	144	129	118	206	146	119	103	92	84	72	51	42	36	32	29	
7.00	3.500	300	278	227	196	176	160	281	198	162	140	125	115	98	69	57	49	44	40	
	4.000	300	300	296	257	229	209	300	259	212	183	164	150	128	91	74	64	57	52	
	3.000	247	175	143	124	111	101	177	125	102	88	79	72	62	44	36	31	28	25	
8.00	3.500	300	238	194	168	151	137	241	170	139	120	108	98	84	60	49	42	38	34	
	4.000	300	300	254	220	197	180	300	222	181	157	140	128	110	78	63	55	49	45	
	4.500	300	300	300	278	249	227	300	281	230	199	178	162	139	98	80	70	62	57	
10.00	5.000	300	300	300	300	300	281	300	300	283	245	220	200	172	121	99	86	77	70	
	3.500	295	208	170	147	132	120	210	149	122	105	94	86	74	52	43	37	33	30	
	4.000	300	272	222	192	172	157	275	194	159	137	123	112	96	68	56	48	43	39	
12.00	4.500	300	300	281	244	218	199	300	246	201	174	156	142	122	86	70	61	54	50	
	5.000	300	300	300	300	269	245	300	300	248	215	192	175	150	106	87	75	67	61	
	5.500	300	300	300	300	300	297	300	300	300	260	232	212	182	129	105	91	81	74	
14.00	4.500	300	276	225	195	174	159	278	197	161	139	124	114	97	69	56	49	44	40	
	5.000	300	300	278	241	215	196	300	243	198	172	154	140	120	85	69	60	54	49	
	5.500	300	300	300	291	260	238	300	294	240	208	186	170	146	103	84	73	65	59	
16.00	7.000	300	300	300	300	300	300	300	300	300	300	300	275	236	167	136	118	105	96	
	8.000	300	300	300	280	243	217	198	300	245	200	173	155	141	121	86	70	61	54	50
	7.000	300	300	300	300	300	300	300	300	300	281	251	229	196	139	113	98	88	80	
18.00	8.000	300	300	300	300	300	300	300	300	300	300	300	299	257	181	148	128	115	105	
	7.000	300	300	300	300	300	275	300	300	278	241	215	196	168	119	97	84	75	69	
	8.000	300	300	300	300	300	300	300	300	300	300	281	256	220	155	127	110	98	90	
20.00	10.000	300	300	300	300	300	300	300	300	300	300	300	300	300	243	198	172	154	140	
	8.000	300	300	300	300	300	300	300	300	300	275	246	224	192	136	111	96	86	79	
	9.000	300	300	300	300	300	300	300	300	300	300	300	284	244	172	141	122	109	99	
18.00	10.000	300	300	300	300	300	300	300	300	300	300	300	300	300	213	174	150	134	123	
	9.000	300	300	300	300	300	300	300	300	300	300	277	252	216	153	125	108	97	88	
20.00	10.000	300	300	300	300	300	300	300	300	300	300	300	300	267	189	154	134	120	109	
	10.000	300	300	300	300	300	300	300	300	300	300	300	281	241	170	139	120	108	98	

<sup>1</sup> Maximum operating pressure is limited for Mounting Styles J and JB. Please refer to maximum operating pressure per bore in Pressure Ratings table located on the dimension page for each of these mounting styles.

**Piston Rod Selection Data**

**Maximum Basic Lengths (L<sub>A</sub>) (all dimensions in inches)**

Bore Ø	Rod Ø	Rear Fixed Mounts (H', HB', HH, TC)																			
		Fixed and Rigidly Guided Rod End Max. Allowable Basic Length (L <sub>A</sub> ) at psi:						Pivoted and Rigidly Guided Rod End Max. Allowable Basic Length (L <sub>A</sub> ) at psi:						Unguided Rod End Max. Allowable Basic Length (L <sub>A</sub> ) at psi:							
		500	1000	1500	2000	2500	3000	500	1000	1500	2000	2500	3000	500	1000	1500	2000	2500	3000		
1.50	0.625	70	50	40	35	31	29	50	35	29	25	22	20	18	12	10	9	8	7		
	1.000	170	120	98	85	76	69	121	86	70	61	54	50	42	30	25	21	19	17		
2.00	1.000	132	93	76	66	59	54	94	67	54	47	42	38	33	23	19	16	15	13		
	1.375	232	164	134	116	104	95	166	117	96	83	74	68	58	41	33	29	26	24		
2.50	1.000	107	76	62	54	48	44	77	54	44	38	34	31	27	19	16	13	12	11		
	1.375	197	140	114	99	88	81	141	100	81	70	63	58	49	35	28	25	22	20		
	1.750	300	213	174	151	135	123	215	152	124	108	96	88	75	53	43	38	34	31		
3.25	1.375	156	110	90	78	70	64	111	79	64	56	50	45	39	28	22	19	17	16		
	1.750	246	174	142	123	110	100	176	124	102	88	79	72	62	44	36	31	28	25		
	2.000	300	221	181	157	140	128	224	158	129	112	100	91	78	55	45	39	35	32		
4.00	1.750	203	144	117	102	91	83	145	103	84	73	65	59	51	36	29	25	23	21		
	2.000	261	185	151	131	117	107	187	132	108	93	83	76	65	46	38	33	29	27		
	2.500	300	274	224	194	173	158	277	196	160	138	124	113	97	69	56	48	43	40		
5.00	2.000	214	151	123	107	96	87	153	108	88	76	68	62	53	38	31	27	24	22		
	2.500	300	231	188	163	146	133	233	165	135	117	104	95	82	58	47	41	36	33		
	3.000	300	300	261	226	202	184	300	228	186	161	144	132	113	80	65	56	50	46		
	3.500	300	300	300	289	259	236	300	292	239	207	185	169	145	102	83	72	65	59		
6.00	2.500	278	197	161	139	124	114	199	141	115	99	89	81	70	49	40	35	31	28		
	3.000	300	278	227	197	176	161	281	199	162	140	126	115	98	70	57	49	44	40		
	3.500	300	300	300	260	233	212	300	263	215	186	166	152	130	92	75	65	58	53		
	4.000	300	300	300	300	292	266	300	300	269	233	208	190	163	115	94	82	73	67		
7.00	3.000	300	241	197	171	153	139	244	172	141	122	109	100	85	60	49	43	38	35		
	3.500	300	300	263	228	204	186	300	230	188	163	146	133	114	81	66	57	51	46		
	4.000	300	300	300	289	259	236	300	292	239	207	185	169	145	102	83	72	65	59		
	4.500	300	300	300	300	300	288	300	300	290	252	225	205	176	124	102	88	79	72		
	5.000	300	300	300	300	300	300	300	300	300	296	264	241	207	146	119	103	93	84		
8.00	3.500	300	288	235	203	182	166	291	205	168	145	130	119	102	72	59	51	45	42		
	4.000	300	300	300	261	234	213	300	264	216	187	167	152	131	92	75	65	58	53		
	4.500	300	300	300	300	290	264	300	300	267	231	207	189	162	114	93	81	72	66		
	5.000	300	300	300	300	300	300	300	300	300	277	248	226	194	137	112	97	87	79		
	5.500	300	300	300	300	300	300	300	300	300	300	289	264	226	160	131	113	101	92		
10.00	4.500	300	300	300	269	241	220	300	272	222	192	172	157	135	95	78	67	60	55		
	5.000	300	300	300	300	294	268	300	300	271	235	210	192	164	116	95	82	73	67		
	5.500	300	300	300	300	300	300	300	300	300	280	250	229	196	139	113	98	88	80		
	7.000	300	300	300	300	300	300	300	300	300	300	300	300	296	209	171	148	132	121		
12.00	5.500	300	300	300	300	299	273	300	300	276	239	213	195	167	118	96	84	75	68		
	7.000	300	300	300	300	300	300	300	300	300	300	300	300	260	184	150	130	116	106		
	8.000	300	300	300	300	300	300	300	300	300	300	300	300	300	231	189	163	146	133		
14.00	7.000	300	300	300	300	300	300	300	300	300	300	300	300	291	266	228	161	132	114	102	93
	8.000	300	300	300	300	300	300	300	300	300	300	300	300	290	205	167	145	129	118		
	10.000	300	300	300	300	300	300	300	300	300	300	300	300	300	293	240	207	186	169		
16.00	8.000	300	300	300	300	300	300	300	300	300	300	300	300	260	184	150	130	116	106		
	9.000	300	300	300	300	300	300	300	300	300	300	300	300	300	227	186	161	144	131		
	10.000	300	300	300	300	300	300	300	300	300	300	300	300	300	272	222	192	172	157		
18.00	9.000	300	300	300	300	300	300	300	300	300	300	300	300	293	207	169	146	131	119		
	10.000	300	300	300	300	300	300	300	300	300	300	300	300	300	250	204	177	158	144		
20.00	10.000	300	300	300	300	300	300	300	300	300	300	300	300	300	231	188	163	146	133		

<sup>1</sup> Maximum operating pressure is limited for Mounting Styles H and HB. Please refer to maximum operating pressure per bore in Pressure Ratings table located on the dimension page for each of these mounting styles.



**Piston Rod Selection Data**

**Maximum Basic Lengths (L<sub>A</sub>) (all dimensions in inches)**

Bore Ø	Rod Ø	Rear Pivot Mounts (BB, SB <sup>1</sup> , SE, DB)						Front and Intermediate Pivot Mounts (D, DD, DE)					
		Pivoted & Rigidly Guided Rod End Max. Allowable Basic Length (L <sub>A</sub> ) at psi:						Pivoted & Rigidly Guided Rod End Max. Allowable Basic Length (L <sub>A</sub> ) at psi:					
		500	1000	1500	2000	2500	3000	500	1000	1500	2000	2500	3000
1.50	0.625	35	25	20	18	16	14	25	18	14	13	11	10
	1.000	85	60	49	42	38	35	64	45	37	32	29	26
2.00	1.000	66	47	38	33	29	27	48	34	28	24	22	20
	1.375	116	82	67	58	52	47	91	64	53	45	41	37
2.50	1.000	54	38	31	27	24	22	38	27	22	19	17	16
	1.375	99	70	57	49	44	40	73	51	42	36	33	30
	1.750	151	106	87	75	67	61	118	83	68	59	53	48
3.25	1.375	78	55	45	39	35	32	56	40	32	28	25	23
	1.750	123	87	71	62	55	50	91	64	52	45	41	37
	2.000	157	111	90	78	70	64	118	84	68	59	53	48
4.00	1.750	102	72	59	51	45	41	74	52	43	37	33	30
	2.000	131	92	75	65	58	53	96	68	56	48	43	39
	2.500	194	137	112	97	87	79	150	106	87	75	67	61
5.00	2.000	107	76	62	53	48	44	77	54	44	38	34	31
	2.500	163	115	94	82	73	67	120	85	69	60	54	49
	3.000	226	160	130	113	101	92	173	122	100	87	77	71
	3.500	289	204	167	145	129	118	236	167	136	118	105	96
6.00	2.500	139	98	80	70	62	57	100	71	58	50	45	41
	3.000	197	139	114	98	88	80	144	102	83	72	65	59
	3.500	260	184	150	130	116	106	196	139	113	98	88	80
	4.000	300	231	188	163	146	133	257	181	148	128	115	105
7.00	3.000	171	121	99	85	76	70	124	87	71	62	55	50
	3.500	228	161	132	114	102	93	168	119	97	84	75	69
	4.000	289	204	167	145	129	118	220	155	127	110	98	90
	4.500	300	249	203	176	157	144	278	197	161	139	124	114
8.00	5.000	300	293	239	207	185	169	300	243	198	172	154	140
	3.500	203	144	117	102	91	83	147	104	85	74	66	60
	4.000	261	185	151	131	117	107	192	136	111	96	86	79
	4.500	300	229	187	162	145	132	244	172	141	122	109	99
	5.000	300	274	224	194	174	158	300	213	174	150	134	123
10.00	5.500	300	300	261	226	202	185	300	257	210	182	163	149
	4.500	269	190	155	135	120	110	195	138	112	97	87	80
	5.000	300	232	190	164	147	134	291	206	168	146	130	119
	5.500	300	277	226	196	175	160	300	300	272	236	211	192
12.00	7.000	300	300	300	296	265	242	241	170	139	120	108	98
	5.500	300	236	193	167	149	136	243	171	140	121	108	99
	7.000	300	300	300	260	233	213	300	300	296	257	229	209
14.00	8.000	300	300	300	300	292	267	300	278	227	196	176	160
	7.000	300	300	263	228	204	186	300	238	194	168	151	137
	8.000	300	300	300	290	259	236	300	300	300	300	300	281
16.00	10.000	300	300	300	300	300	300	300	300	254	220	197	180
	8.000	300	300	300	260	233	213	300	272	222	192	172	157
	9.000	300	300	300	300	288	263	300	300	281	244	218	199
18.00	10.000	300	300	300	300	300	300	300	300	300	300	269	245
	9.000	300	300	300	293	262	239	300	300	250	216	194	177
20.00	10.000	300	300	300	300	289	267	300	300	300	267	239	218

<sup>1</sup> Maximum operating pressure is limited for Mounting Style SB. Please refer to maximum operating pressure per bore in Pressure Ratings table located on the dimension page for Mounting Styles SB.

Engineering Data





### An Introduction to Cushioning

Cushioning is recommended as a means of controlling the deceleration of masses, or for applications where piston speed is in excess of 4 in/sec and the piston will make full stroke. Cushioning extends cylinder life and reduces undesirable noise and hydraulic shock. Built-in "cushions" are optional and can be supplied at the head and cap ends of a cylinder without affecting its envelope or mounting dimensions.

### Standard Cushioning

**Ideal cushion performance shows an almost uniform absorption of energy along the cushioning length, as shown. Many forms of cushioning exist, and each has its own specific merits and advantages.**

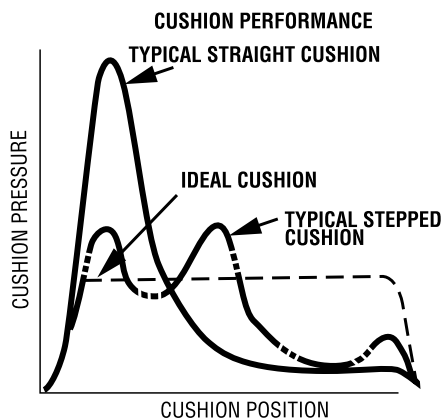

In order to cover the majority of applications, H cylinders are supplied with profiled cushioning as standard. Final speed may be adjusted using the cushion screw. The performance of profiled cushioning is indicated on the diagram, and

cushion performance for each of the rod sizes available is illustrated graphically in the charts on the following pages.

Note: Cushion performance will be affected by the use of water or high water based fluids. Please consult factory for details.

### Cushion Length

Where specified, H cylinders incorporate the longest cushion sleeve and spear that can be accommodated within the standard envelope without reducing the rod bearing and piston bearing length. See cushion lengths on the next page. Cushions are adjustable via recessed needle valves.

### Cushion Calculation

The charts on the cushion energy absorption capacity data page show the energy absorption capacity for each bore/rod combination at the head (annulus) and the cap (full bore) ends of cylinder. The charts are valid for piston velocities within a range of 0.33 to 1 ft/s. For velocities between 1ft/s and 1.64 ft/s the energy values derived from the charts should be reduced by 25%. For velocities less than 0.33 ft/s where large masses are involved, and for velocities greater than 1.60 ft/s, a special cushion profile may be required. Please consult the factory for details.

The cushion capacity of the head end is less than the cap, and reduces to zero at high drive pressures due to the pressure intensification effect across the piston.

The energy absorption capacity of the cushion decreases with drive pressure.

### Formula

Cushioning calculations are based on the formula  $E=(1/2)mv^2$  for horizontal applications. For inclined or vertically downward or upward applications, this is modified to:

$$E = (1/2)mv^2 + mg(L/12) \times \sin(a)$$

(for inclined or vertically downward direction of mass)

$$E = (1/2)mv^2 - mg(L/12) \times \sin(a)$$

(for inclined vertically upward direction of mass)

where:

E = energy absorbed in ft-lb

g = acceleration due to gravity = 32.2 ft/s<sup>2</sup>

v = velocity in ft/s

L = length of cushion in inches (see cushion length chart on the next page).

m = mass of load in slug (including piston, rod and rod end accessories).

a = angle to the horizontal in degrees

p = pressure in psi

### Example:

The following example shows how to calculate the energy developed by masses moving in a straight line. For non-linear motion, other calculations are required; please consult the factory. The example assumes that the bore and rod diameter are already appropriate for the application. The effects of friction on the cylinder and load have been ignored.

Selected bore/rod 6.00" bore x 2.50" rod (No. 1 rod)

Cushion at the cap end.

Pressure = 2,500 psi

Mass = 685 slugs = weight in lb / (32.2 ft/s<sup>2</sup>)

Velocity = 1.3 ft/s

Cushion length = 1.313 inch

a = 45°

Sin (a) = 0.70

$$\begin{aligned} E &= (1/2)mv^2 + mgl/12 \times \sin(a) \\ &= (1/2) \times 685 \times 1.3^2 + 685 \times 32.2 \times 1.313/12 \times 0.70 \\ &= 2,268 \text{ ft-lb} \end{aligned}$$

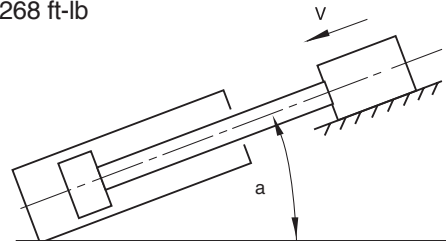

Note: In the above example velocity is greater than 1 ft/s. Therefore, a de-rating factor of 0.75 must be applied to the calculated value of E. Applying this correction factor will increase the energy value to 3024 ft-lb (2268/0.75 = 3024 ft-lb). A review of the graph for the cap end cushion of a 6 inch bore x 2.50" rod cylinder operating at 2500 psi indicates that it can absorb approximately 3200 ft-lb maximum of energy. Since 3024 ft-lb is less than the maximum allowable of 3200 ft-lb, the cylinder can be applied as indicated. If the calculated energy exceeds the value shown on the curve, select a larger bore cylinder and/or reduce the operating pressure and recalculate the energy. Compare the newly calculated energy value to the appropriate curve to ensure it does not exceed the maximum allowable energy.

**Cushion Length Chart (Series H Cylinders)**

Bore Ø	Rod Ø	Effective Cushion Length	
		Head	Cap
1.50	0.625	0.924	1.000
	1.000	0.927	1.000
2.00	1.000	0.927	0.938
	1.375	0.925	0.938
2.50	1.000	0.927	0.938
	1.750	0.928	0.938
	1.375	0.925	0.938
3.25	1.375	1.175	1.125
	2.000	0.862	1.125
	1.750	1.178	1.125
4.00	1.750	1.178	1.063
	2.500	0.869	1.063
	2.000	0.862	1.063
5.00	2.000	0.862	0.938
	3.500	0.869	0.938
	2.500	0.869	0.938
	3.000	0.869	0.938
6.00	2.500	1.119	1.313
	4.000	1.119	1.313
	3.000	1.119	1.313
	3.500	0.869	1.313
7.00	3.000	1.619	1.750
	5.000	1.496	1.750
	3.500	1.619	1.750
	4.000	1.119	1.750
	4.500	1.496	1.750
8.00	3.500	1.869	1.813
	5.500	1.745	1.813
	4.000	1.119	1.813
	4.500	1.496	1.813
	5.000	1.496	1.813



**Cushion Energy Absorption Capacity Data**

The cushion energy absorption data shown below is based on the maximum fatigue-free pressure developed in the tube. For application with a life cycle of less than 10<sup>6</sup> cycles, greater

energy absorption figures can be applied. Please consult the factory if further information is required.

**Head End**

**STANDARD ROD DIA.**

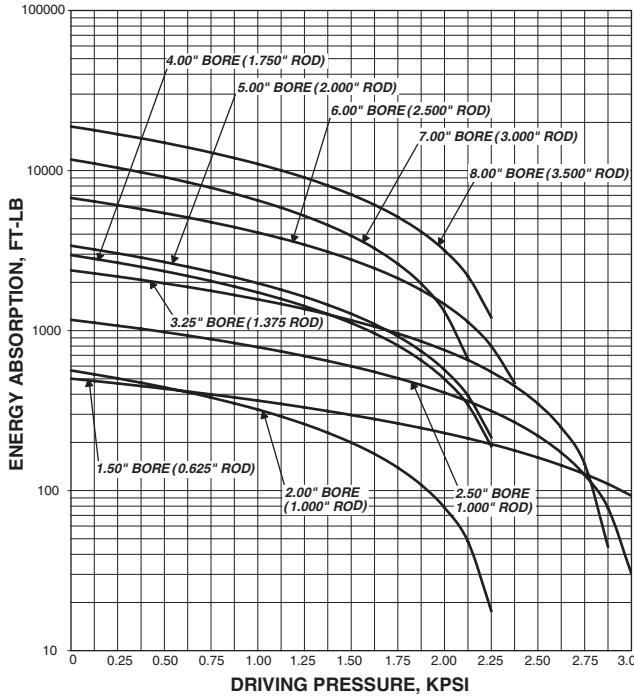

**MAXIMUM ROD DIA.**

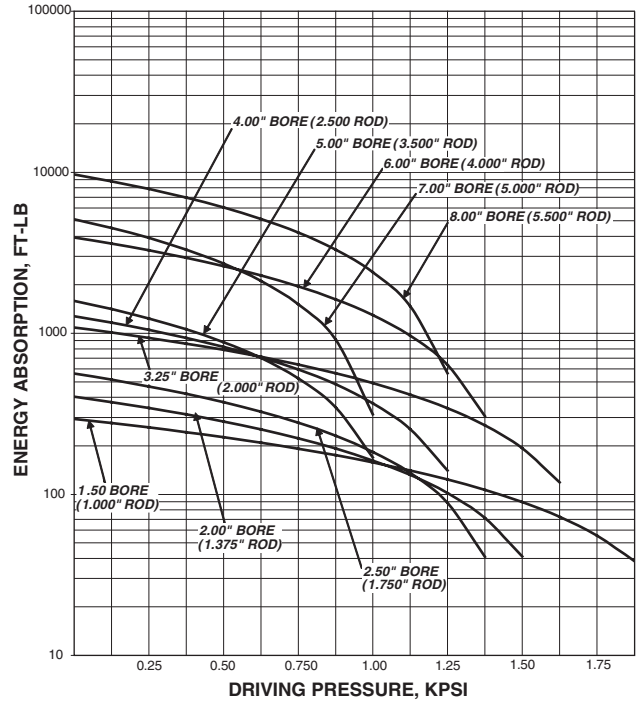

**FIRST OVERSIZE ROD DIA.**

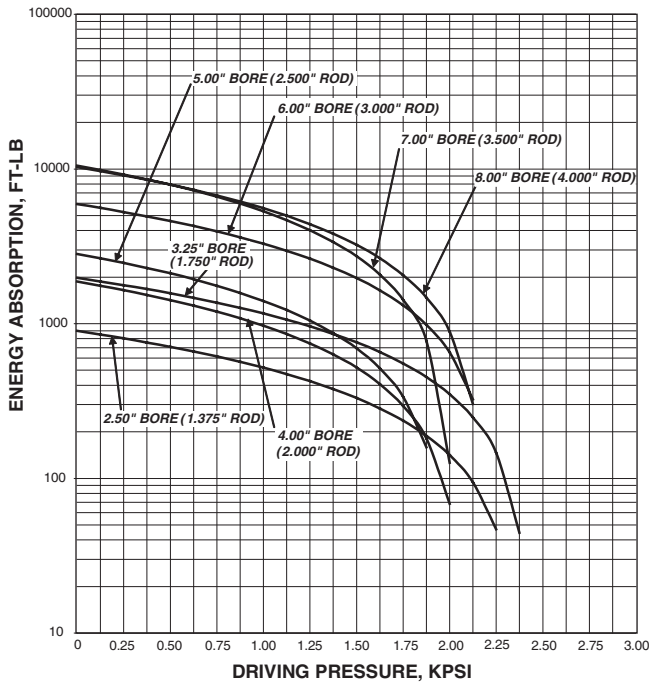

**SECOND OVERSIZE ROD DIA.**

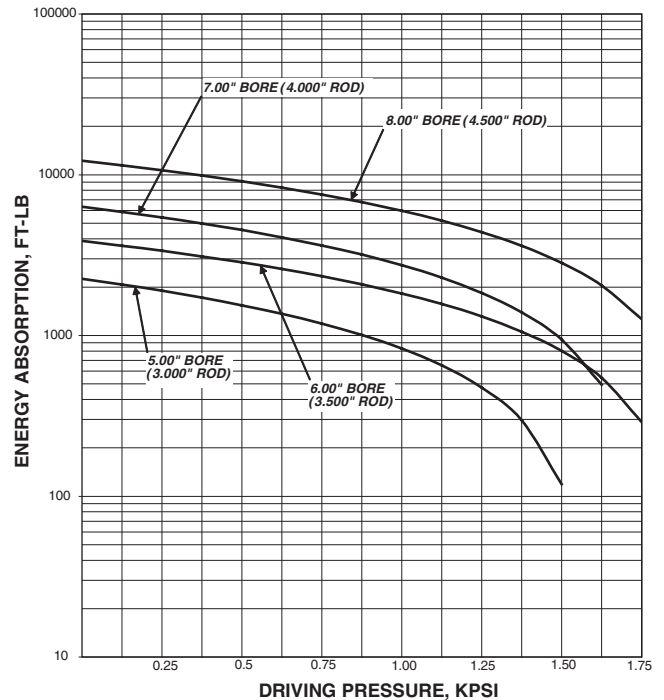

**Cushion Energy Absorption Capacity Data**

The cushion energy absorption data shown below is based on the maximum fatigue-free pressure developed in the tube. For application with a life cycle of less than 10<sup>6</sup> cycles, greater

energy absorption figures can be applied. Please consult the factory if further information is required.

**Head End**

**THIRD OVERSIZE ROD DIA.**

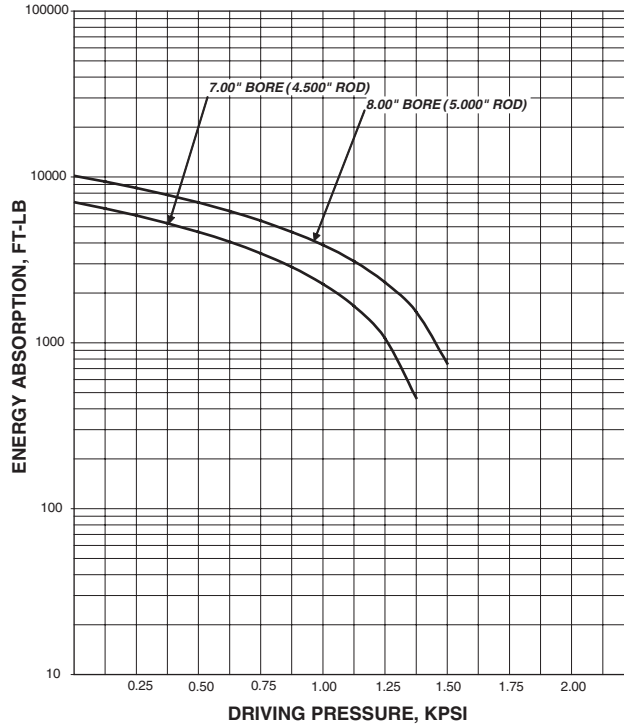

**Cushion Energy Absorption Capacity Data**

The cushion energy absorption data shown below is based on the maximum fatigue-free pressure developed in the tube. For application with a life cycle of less than 10<sup>6</sup> cycles, greater energy absorption figures can be applied. Please consult the factory if further information is required.

**Note: Cap end cushioned cylinders with oversize port and hydraulic fluid flow entering the cap that exceeds 25 ft/second should be specified with solid cap cushion design.**

**Cap End**

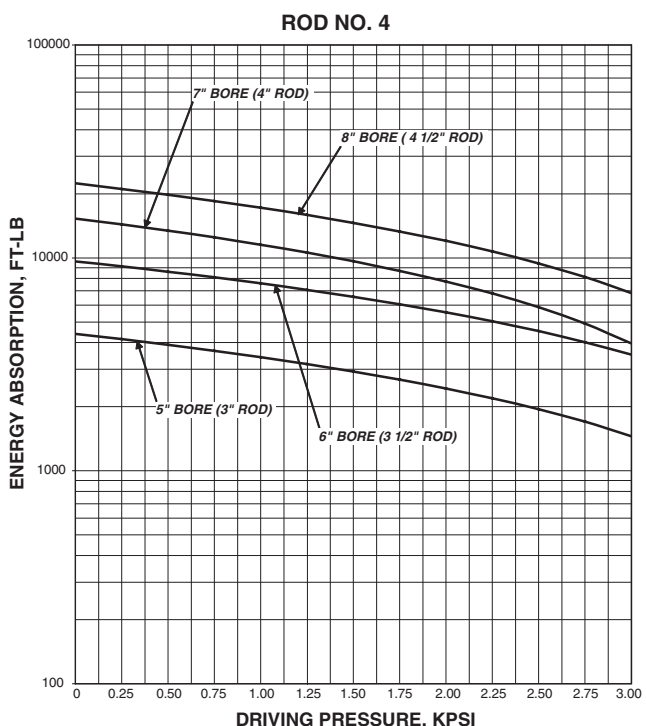
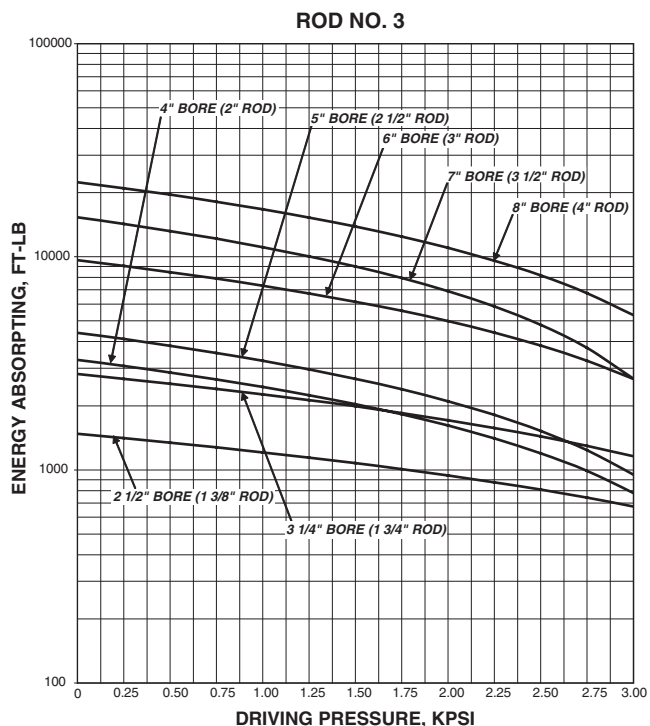
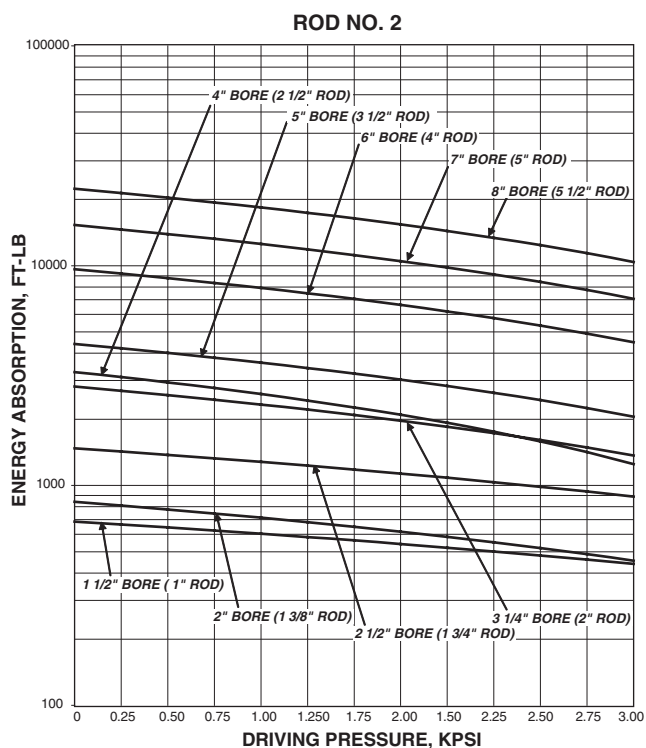
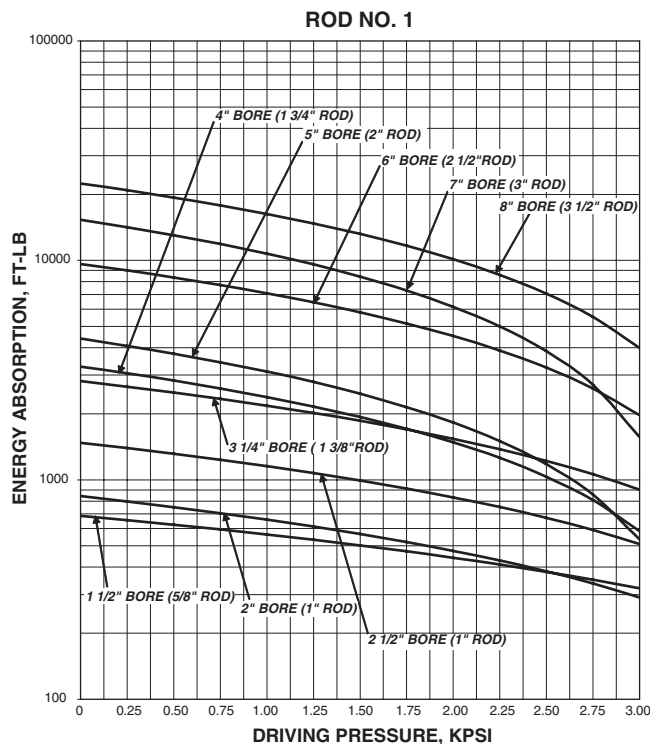

**Cushion Energy Absorption Capacity Data**

The cushion energy absorption data shown below is based on the maximum fatigue-free pressure developed in the tube. For application with a life cycle of less than 10<sup>6</sup> cycles, greater energy absorption figures can be applied. Please consult the factory if further information is required.

**Note: Cap end cushioned cylinders with oversize port and hydraulic fluid flow entering the cap that exceeds 25 ft/second should be specified with solid cap cushion design.**

**Cap End**

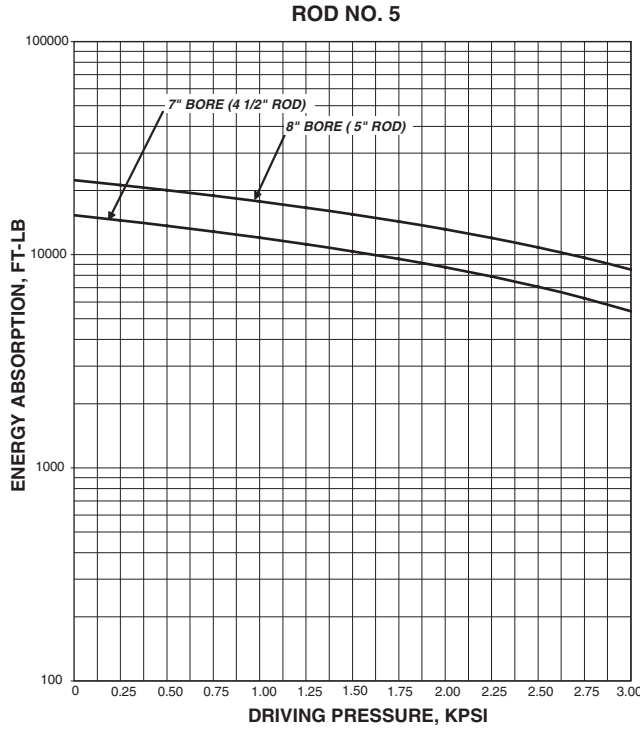

**Notes**

A large grid area for taking notes, consisting of a 30x30 grid of small squares.

**D**  
Engineering Data

**For more information about Atlas H Series  
see the Maintenance / Design Manual**

**Series H  
Maintenance /  
Design Manual**

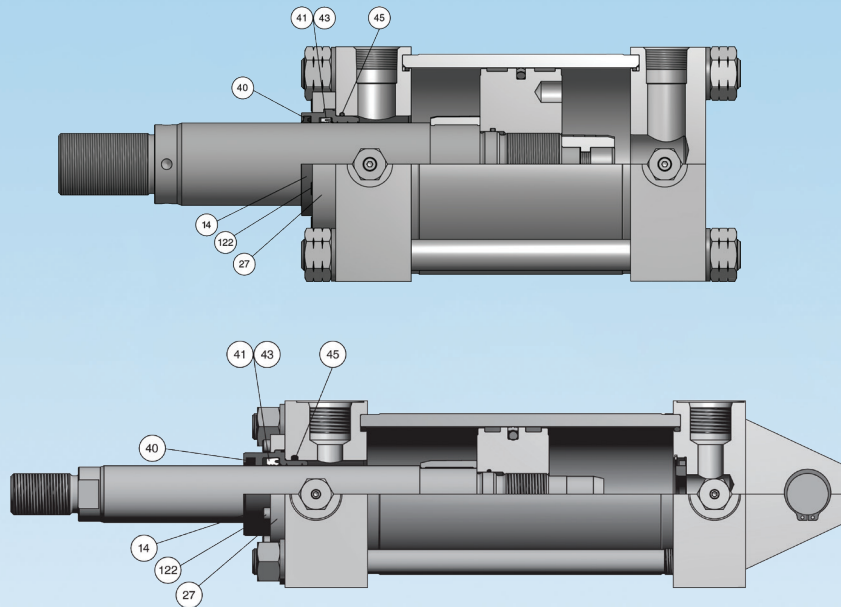

**ATLAS**<sup>TM</sup>  
CYLINDERS

Engineering Data  
**D**



## Atlas offers a complete line of cylinder mounting accessories



### Cylinder Mounting Accessories

Catalog HY08-AC1300-1/NA

aerospace  
climate control  
electromechanical  
filtration  
fluid & gas handling  
hydraulics  
pneumatics  
process control  
sealing & shielding

**ATLAS**<sup>TM</sup>  
**CYLINDERS**

**Notes**

A large grid area for taking notes, consisting of approximately 30 columns and 40 rows of small squares.

**Notes**

A large grid area for taking notes, consisting of a 30x30 grid of small squares.

**D**  
Engineering Data

## Safety Guide for Selecting and Using Hydraulic, Pneumatic Cylinders and Their Accessories

**WARNING:** ⚠ **FAILURE OF THE CYLINDER, ITS PARTS, ITS MOUNTING, ITS CONNECTIONS TO OTHER OBJECTS, OR ITS CONTROLS CAN RESULT IN:**

- Unanticipated or uncontrolled movement of the cylinder or objects connected to it.
- Falling of the cylinder or objects held up by it.
- Fluid escaping from the cylinder, potentially at high velocity.

**THESE EVENTS COULD CAUSE DEATH OR PERSONAL INJURY BY, FOR EXAMPLE, PERSONS FALLING FROM HIGH LOCATIONS, BEING CRUSHED OR STRUCK BY HEAVY OR FAST MOVING OBJECTS, BEING PUSHED INTO DANGEROUS EQUIPMENT OR SITUATIONS, OR SLIPPING ON ESCAPED FLUID.**

Before selecting or using Parker Hannifin Corporation (the Company) cylinders or related accessories, it is important that you read, understand and follow the following safety information. Training is advised before selecting and using the Company's products.

### 1.0 General Instructions

**1.1 Scope** – This safety guide provides instructions for selecting and using (including assembling, installing, and maintaining) cylinder products. This safety guide is a supplement to and is to be used with the specific Company publications for the specific cylinder products that are being considered for use.

**1.2 Fail Safe** – Cylinder products can and do fail without warning for many reasons. All systems and equipment should be designed in a fail-safe mode so that if the failure of a cylinder product occurs people and property won't be endangered.

**1.3 Distribution** – Provide a free copy of this safety guide to each person responsible for selecting or using cylinder products. Do not select or use the Company's cylinders without thoroughly reading and understanding this safety guide as well as the specific Company publications for the products considered or selected.

**1.4 User Responsibility** – Due to very wide variety of cylinder applications and cylinder operating conditions, the Company does not warrant that any particular cylinder is suitable for any specific application. This safety guide does not analyze all technical parameters that must be considered in selecting a product. The hydraulic and pneumatic cylinders outlined in this catalog are designed to the Company's design guidelines and do not necessarily meet the design guideline of other agencies such as American Bureau of Shipping, ASME Pressure Vessel Code etc. The user, through its own analysis and testing, is solely responsible for:

- Making the final selection of the cylinders and related accessories.
- Determining if the cylinders are required to meet specific design requirements as required by the Agency(s) or industry standards covering the design of the user's equipment.
- Assuring that the user's requirements are met, OSHA requirements are met, and safety guidelines from the applicable agencies such as but not limited to ANSI are followed and that the use presents no health or safety hazards.
- Providing all appropriate health and safety warnings on the equipment on which the cylinders are used.

**1.5 Additional Questions** – Call the appropriate Company technical service department if you have any questions or require any additional information. See the Company publication for the product being considered or used, or call 1-847-298-2400, or go to [www.parker.com](http://www.parker.com), for telephone numbers of the appropriate technical service department.

### 2.0 Cylinder and Accessories Selection

**2.1 Seals** – Part of the process of selecting a cylinder is the selection of seal compounds. Before making this selection, consult the "seal information page(s)" of the publication for the series of cylinders of interest.

The application of cylinders may allow fluids such as cutting fluids, wash down fluids etc. to come in contact with the external area of the cylinder. These fluids may attack the piston rod wiper and or the primary seal and must be taken into account when selecting and specifying seal compounds.

Dynamic seals will wear. The rate of wear will depend on many operating factors. Wear can be rapid if a cylinder is mis-aligned or if the cylinder has been improperly serviced. The user must take seal wear into consideration in the application of cylinders.

**2.2 Piston Rods** – Possible consequences of piston rod failure or separation of the piston rod from the piston include, but are not limited to are:

- Piston rod and or attached load thrown off at high speed.
- High velocity fluid discharge.
- Piston rod extending when pressure is applied in the piston retract mode.

Piston rods or machine members attached to the piston rod may move suddenly and without warning as a consequence of other conditions occurring to the machine such as, but not limited to:

- Unexpected detachment of the machine member from the piston rod.

- Failure of the pressurized fluid delivery system (hoses, fittings, valves, pumps, compressors) which maintain cylinder position.
- Catastrophic cylinder seal failure leading to sudden loss of pressurized fluid.
- Failure of the machine control system.

Follow the recommendations of the "Piston Rod Selection Chart and Data" in the publication for the series of cylinders of interest. The suggested piston rod diameter in these charts must be followed in order to avoid piston rod buckling.

Piston rods are not normally designed to absorb bending moments or loads which are perpendicular to the axis of piston rod motion. These additional loads can cause the piston rod to fail. If these types of additional loads are expected to be imposed on the piston rod, their magnitude should be made known to our engineering department.

The cylinder user should always make sure that the piston rod is securely attached to the machine member.

On occasion cylinders are ordered with double rods (a piston rod extended from both ends of the cylinder). In some cases a stop is threaded on to one of the piston rods and used as an external stroke adjuster. On occasions spacers are attached to the machine member connected to the piston rod and also used as a stroke adjuster. In both cases the stops will create a pinch point and the user should consider appropriate use of guards. If these external stops are not perpendicular to the mating contact surface, or if debris is trapped between the contact surfaces, a bending moment will be placed on the piston rod, which can lead to piston rod failure. An external stop will also negate the effect of cushioning and will subject the piston rod to impact loading. Those two (2) conditions can cause piston rod failure. Internal stroke adjusters are available with and without cushions. The use of external stroke adjusters should be reviewed with our engineering department.

The piston rod to piston and the stud to piston rod threaded connections are secured with an anaerobic adhesive. The strength of the adhesive decreases with increasing temperature. Cylinders which can be exposed to temperatures above +250°F (+121°C) are to be ordered with a non studded piston rod and a pinned piston rod joint.

**2.3 Cushions** – Cushions should be considered for cylinder applications when the piston velocity is expected to be over 4 inches/second.

Cylinder cushions are normally designed to absorb the energy of a linear applied load. A rotating mass has considerably more energy than the same mass moving in a linear mode. Cushioning for a rotating mass application should be reviewed by our engineering department.

**2.4 Cylinder Mountings** – Some cylinder mounting configurations may have certain limitations such as but not limited to minimum stroke for side or foot mounting cylinders or pressure de-ratings for certain mounts. Carefully review the catalog for these types of restrictions.

Always mount cylinders using the largest possible high tensile alloy steel socket head cap screws that can fit in the cylinder mounting holes and torque them to the manufacturer's recommendations for their size.

**2.5 Port Fittings** – Hydraulic cylinders applied with meter out or deceleration circuits are subject to intensified pressure at piston rod end.

The rod end pressure is approximately equal to:

$$\frac{\text{operating pressure} \times \text{effective cap end area}}{\text{effective rod end piston area}}$$

Contact your connector supplier for the pressure rating of individual connectors.

### 3.0 Cylinder and Accessories Installation and Mounting

#### 3.1 Installation

**3.1.1** – Cleanliness is an important consideration, and cylinders are shipped with the ports plugged to protect them from contaminants entering the ports. These plugs should not be removed until the piping is to be installed. Before making the connection to the cylinder ports, piping should be thoroughly cleaned to remove all chips or burrs which might have resulted from threading or flaring operations.

**3.1.2** – Cylinders operating in an environment where air drying materials are present such as fast-drying chemicals, paint, or weld splatter, or other hazardous conditions such as excessive heat, should have shields installed to prevent damage to the piston rod and piston rod seals.

**3.1.3** – Proper alignment of the cylinder piston rod and its mating component on the machine should be checked in both the extended and retracted positions. Improper alignment will result in excessive rod bushing and/or cylinder bore wear. On fixed mounting cylinders attaching the piston rod while the rod is retracted will help in achieving proper alignment.

**3.1.4** – Sometimes it may be necessary to rotate the piston rod in order to thread the piston rod into the machine member. This operation must always be done with zero pressure being applied to either side of the piston. Failure to follow this procedure may result in loosening the piston to rod-threaded connection. In some rare cases the turning of the piston rod may rotate a threaded piston rod bushing and loosen it from the cylinder head. Confirm that this condition is not occurring. If it does, re-tighten the piston rod bushing firmly against the cylinder head.

For double rod cylinders it is also important that when attaching or detaching the piston rod from the machine member that the torque be applied to the piston rod end of the cylinder that is directly attaching to the machine member with the opposite end unrestrained. If the design of the machine is such that only the rod end of the cylinder opposite to where the rod attaches to the machine member can be rotated, consult the factory for further instructions.

### **3.2 Mounting Recommendations**

**3.2.1** – Always mount cylinders using the largest possible high tensile alloy steel socket head screws that can fit in the cylinder mounting holes and torque them to the manufacturer's recommendations for their size.

**3.2.2** – Side-Mounted Cylinders – In addition to the mounting bolts, cylinders of this type should be equipped with thrust keys or dowel pins located so as to resist the major load.

**3.2.3** – Tie Rod Mounting – Cylinders with tie rod mountings are recommended for applications where mounting space is limited. The standard tie rod extension is shown as BB in dimension tables. Longer or shorter extensions can be supplied. Nuts used for this mounting style should be torqued to the same value as the tie rods for that bore size.

**3.2.4** – Flange Mount Cylinders – The controlled diameter of the rod bushing extension on head end flange mount cylinders can be used as a pilot to locate the cylinders in relation to the machine. After alignment has been obtained, the flanges may be drilled for pins or dowels to prevent shifting.

**3.2.5** – Trunnion Mountings – Cylinders require lubricated bearing blocks with minimum bearing clearances. Bearing blocks should be carefully aligned and rigidly mounted so the trunnions will not be subjected to bending moments. The rod end should also be pivoted with the pivot pin in line and parallel to axis of the trunnion pins.

**3.2.6** – Clevis Mountings – Cylinders should be pivoted at both ends with centerline of pins parallel to each other. After cylinder is mounted, be sure to check to assure that the cylinder is free to swing through its working arc without interference from other machine parts.

### **4.0 Cylinder and Accessories Maintenance, Troubleshooting and Replacement**

**4.1 Storage** – At times cylinders are delivered before a customer is ready to install them and must be stored for a period of time. When storage is required the following procedures are recommended.

**4.1.1** – Store the cylinders in an indoor area which has a dry, clean and noncorrosive atmosphere. Take care to protect the cylinder from both internal corrosion and external damage.

**4.1.2** – Whenever possible cylinders should be stored in a vertical position (piston rod up). This will minimize corrosion due to possible condensation which could occur inside the cylinder. This will also minimize seal damage.

**4.1.3** – Port protector plugs should be left in the cylinder until the time of installation.

**4.1.4** – If a cylinder is stored full of hydraulic fluid, expansion of the fluid due to temperature changes must be considered. Installing a check valve with free flow out of the cylinder is one method.

**4.1.5** – When cylinders are mounted on equipment that is stored outside for extended periods, exposed unpainted surfaces, e.g. piston rod, must be coated with a rust-inhibiting compound to prevent corrosion.

#### **4.2 Cylinder Trouble Shooting**

##### **4.2.1 – External Leakage**

**4.2.1.1** – Rod seal leakage can generally be traced to worn or damaged seals. Examine the piston rod for dents, gouges or score

marks, and replace piston rod if surface is rough.

Rod seal leakage could also be traced to bushing wear. If clearance is excessive, replace rod bushing and seal. Rod seal leakage can also be traced to seal deterioration. If seals are soft or gummy or brittle, check compatibility of seal material with lubricant used if air cylinder, or operating fluid if hydraulic cylinder. Replace with seal material, which is compatible with these fluids. If the seals are hard or have lost elasticity, it is usually due to exposure to temperatures in excess of 165°F. (+74°C). Shield the cylinder from the heat source to limit temperature to 350°F. (+177°C.) and replace with fluorocarbon seals.

**4.2.1.2** – Cylinder body seal leak can generally be traced to loose tie rods. Torque the tie rods to manufacturer's recommendation for that bore size.

Excessive pressure can also result in cylinder body seal leak. Determine maximum pressure to rated limits. Replace seals and retorquing tie rods as in paragraph above. Excessive pressure can also result in cylinder body seal leak. Determine if the pressure rating of the cylinder has been exceeded. If so, bring the operating pressure down to the rating of the cylinder and have the tie rods replaced.

Pinched or extruded cylinder body seal will also result in a leak. Replace cylinder body seal and retorquing as in paragraph above.

Cylinder body seal leakage due to loss of radial squeeze which shows up in the form of flat spots or due to wear on the O.D. or I.D. – Either of these are symptoms of normal wear due to high cycle rate or length of service. Replace seals as per paragraph above.

##### **4.2.2 – Internal Leakage**

**4.2.2.1** – Piston seal leak (by-pass) 1 to 3 cubic inches per minute leakage is considered normal for piston ring construction. Virtually no static leak with lipseal type seals on piston should be expected. Piston seal wear is a usual cause of piston seal leakage. Replace seals as required.

**4.2.2.2** – With lipseal type piston seals excessive back pressure due to over-adjustment of speed control valves could be a direct cause of rapid seal wear. Contamination in a hydraulic system can result in a scored cylinder bore, resulting in rapid seal wear. In either case, replace piston seals as required.

**4.2.2.3** – What appears to be piston seal leak, evidenced by the fact that the cylinder drifts, is not always traceable to the piston. To make sure, it is suggested that one side of the cylinder piston be pressurized and the fluid line at the opposite port be disconnected. Observe leakage. If none is evident, seek the cause of cylinder drift in other component parts in the circuit.

##### **4.2.3 – Cylinder Fails to Move the Load**

**4.2.3.1** – Pneumatic or hydraulic pressure is too low. Check the pressure at the cylinder to make sure it is to circuit requirements.

**4.2.3.2** – Piston Seal Leak – Operate the valve to cycle the cylinder and observe fluid flow at valve exhaust ports at end of cylinder stroke. Replace piston seals if flow is excessive.

**4.2.3.3** – Cylinder is undersized for the load – Replace cylinder with one of a larger bore size.

##### **4.3 Erratic or Chatter Operation**

**4.3.1** – Excessive friction at rod bushing or piston bearing due to load misalignment – Correct cylinder-to-load alignment.

**4.3.2** – Cylinder sized too close to load requirements – Reduce load or install larger cylinder.

**4.3.3** – Erratic operation could be traced to the difference between static and kinetic friction. Install speed control valves to provide a back pressure to control the stroke.

**4.4 Cylinder Modifications, Repairs, or Failed Component** – Cylinders as shipped from the factory are not to be disassembled and or modified. If cylinders require modifications, these modifications must be done at company locations or by the Company's certified facilities. The Cylinder Division Engineering Department must be notified in the event of a mechanical fracture or permanent deformation of any cylinder component (excluding seals). This includes a broken piston rod, tie rod, mounting accessory or any other cylinder component. The notification should include all operation and application details. This information will be used to provide an engineered repair that will prevent recurrence of the failure.

It is allowed to disassemble cylinders for the purpose of replacing seals or seal assemblies. However, this work must be done by strictly following all the instructions provided with the seal kits.



## Offer of Sale

The items described in this document and other documents and descriptions provided by Parker Hannifin Corporation, its subsidiaries and its authorized distributors ("Seller") are hereby offered for sale at prices to be established by Seller. This offer and its acceptance by any customer ("Buyer") shall be governed by all of the following Terms and Conditions. Buyer's order for any item described in its document, when communicated to Seller verbally, or in writing, shall constitute acceptance of this offer. All goods, services or work described will be referred to as "Products".

**1. Terms and Conditions.** Seller's willingness to offer Products, or accept an order for Products, to or from Buyer is subject to these Terms and Conditions or any newer version of the terms and conditions found on-line at [www.parker.com/saleterms/](http://www.parker.com/saleterms/). Seller objects to any contrary or additional terms or conditions of Buyer's order or any other document issued by Buyer.

**2. Price Adjustments; Payments.** Prices stated on Seller's quote or other documentation offered by Seller are valid for 30 days, and do not include any sales, use, or other taxes unless specifically stated. Unless otherwise specified by Seller, all prices are F.C.A. Seller's facility (INCOTERMS 2010). Payment is subject to credit approval and is due 30 days from the date of invoice or such other term as required by Seller's Credit Department, after which Buyer shall pay interest on any unpaid invoices at the rate of 1.5% per month or the maximum allowable rate under applicable law.

**3. Delivery Dates; Title and Risk; Shipment.** All delivery dates are approximate and Seller shall not be responsible for any damages resulting from any delay. Regardless of the manner of shipment, title to any products and risk of loss or damage shall pass to Buyer upon placement of the products with the shipment carrier at Seller's facility. Unless otherwise stated, Seller may exercise its judgment in choosing the carrier and means of delivery. No deferral of shipment at Buyers' request beyond the respective dates indicated will be made except on terms that will indemnify, defend and hold Seller harmless against all loss and additional expense. Buyer shall be responsible for any additional shipping charges incurred by Seller due to Buyer's acts or omissions.

**4. Warranty.** Seller warrants that the Products sold hereunder shall be free from defects in material or workmanship for a period of eighteen months from the date of delivery to Buyer. The prices charged for Seller's products are based upon the exclusive limited warranty stated above, and upon the following disclaimer: **DISCLAIMER OF WARRANTY: THIS WARRANTY COMPRISES THE SOLE AND ENTIRE WARRANTY PERTAINING TO PRODUCTS PROVIDED HEREUNDER. SELLER DISCLAIMS ALL OTHER WARRANTIES, EXPRESS AND IMPLIED, INCLUDING DESIGN, MERCHANTABILITY AND FITNESS FOR A PARTICULAR PURPOSE.**

**5. Claims; Commencement of Actions.** Buyer shall promptly inspect all Products upon delivery. No claims for shortages will be allowed unless reported to the Seller within 10 days of delivery. No other claims against Seller will be allowed unless asserted in writing within 30 days after delivery. Buyer shall notify Seller of any alleged breach of warranty within 30 days after the date the defect is or should have been discovered by Buyer. Any action based upon breach of this agreement or upon any other claim arising out of this sale (other than an action by Seller for an amount due on any invoice) must be commenced within 12 months from the date of the breach without regard to the date breach is discovered.

**6. LIMITATION OF LIABILITY.** UPON NOTIFICATION, SELLER WILL, AT ITS OPTION, REPAIR OR REPLACE A DEFECTIVE PRODUCT, OR REFUND THE PURCHASE PRICE. IN NO EVENT SHALL SELLER BE LIABLE TO BUYER FOR ANY SPECIAL, INDIRECT, INCIDENTAL OR CONSEQUENTIAL DAMAGES ARISING OUT OF, OR AS THE RESULT OF, THE SALE, DELIVERY, NON-DELIVERY, SERVICING, USE OR LOSS OF USE OF THE PRODUCTS OR ANY PART THEREOF, OR FOR ANY CHARGES OR EXPENSES OF ANY NATURE INCURRED WITHOUT SELLER'S WRITTEN CONSENT, EVEN IF SELLER HAS BEEN NEGLIGENT, WHETHER IN CONTRACT, TORT OR OTHER LEGAL THEORY. IN NO EVENT SHALL SELLER'S LIABILITY UNDER ANY CLAIM MADE BY BUYER EXCEED THE PURCHASE PRICE OF THE PRODUCTS.

**7. User Responsibility.** The user, through its own analysis and testing, is solely responsible for making the final selection of the system and Product and assuring that all performance, endurance, maintenance, safety and warning requirements of the application are met. The user must analyze all aspects of the application and follow applicable industry standards and Product information. If Seller provides Product or system options, the user is responsible for determining that such data and specifications are suitable and sufficient for all applications and reasonably foreseeable uses of the Products or systems.

**8. Loss to Buyer's Property.** Any designs, tools, patterns, materials, drawings, confidential information or equipment furnished by Buyer or any other items which become Buyer's property, will be considered obsolete and may be destroyed by Seller after two consecutive years have elapsed without Buyer ordering the items manufactured using such property. Seller shall not be responsible for any loss or damage to such property while it is in Seller's possession or control.

**9. Special Tooling.** A tooling charge may be imposed for any special tooling, including without limitation, dies, fixtures, molds and patterns, acquired to manufacture Products. Such special tooling shall be and remain Seller's property notwithstanding payment of any charges by Buyer. In no event will Buyer acquire any interest in apparatus belonging to Seller which is utilized in the manufacture of the Products, even if such apparatus has been specially converted or adapted for such manufacture and notwithstanding any charges paid by Buyer. Unless otherwise agreed, Seller shall have the right to alter, discard or otherwise dispose of any special tooling or other property in its sole discretion at any time.

**10. Buyer's Obligation; Rights of Seller.** To secure payment of all sums due or otherwise, Seller shall retain a security interest in the goods delivered and this agreement shall be deemed a Security Agreement under the Uniform Commercial Code. Buyer authorizes Seller as its attorney to execute and file on Buyer's behalf all documents Seller deems necessary to perfect its security interest.

**11. Improper use and Indemnity.** Buyer shall indemnify, defend, and hold Seller harmless from any claim, liability, damages, lawsuits, and costs (including attorney fees), whether for personal injury, property damage, patent, trademark or copyright

infringement or any other claim, brought by or incurred by Buyer, Buyer's employees, or any other person, arising out of: (a) improper selection, improper application or other misuse of Products purchased by Buyer from Seller; (b) any act or omission, negligent or otherwise, of Buyer; (c) Seller's use of patterns, plans, drawings, or specifications furnished by Buyer to manufacture Product; or (d) Buyer's failure to comply with these terms and conditions. Seller shall not indemnify Buyer under any circumstance except as otherwise provided.

**12. Cancellations and Changes.** Orders shall not be subject to cancellation or change by Buyer for any reason, except with Seller's written consent and upon terms that will indemnify, defend and hold Seller harmless against all direct, incidental and consequential loss or damage. Seller may change product features, specifications, designs and availability with notice to Buyer.

**13. Limitation on Assignment.** Buyer may not assign its rights or obligations under this agreement without the prior written consent of Seller.

**14. Force Majeure.** Seller does not assume the risk and shall not be liable for delay or failure to perform any of Seller's obligations by reason of circumstances beyond the reasonable control of Seller (hereinafter "Events of Force Majeure"). Events of Force Majeure shall include without limitation: accidents, strikes or labor disputes, acts of any government or government agency, acts of nature, delays or failures in delivery from carriers or suppliers, shortages of materials, or any other cause beyond Seller's reasonable control.

**15. Waiver and Severability.** Failure to enforce any provision of this agreement will not waive that provision nor will any such failure prejudice Seller's right to enforce that provision in the future. Invalidation of any provision of this agreement by legislation or other rule of law shall not invalidate any other provision herein. The remaining provisions of this agreement will remain in full force and effect.

**16. Termination.** Seller may terminate this agreement for any reason and at any time by giving Buyer thirty (30) days written notice of termination. Seller may immediately terminate this agreement, in writing, if Buyer: (a) commits a breach of any provision of this agreement (b) appoints a trustee, receiver or custodian for all or any part of Buyer's property (c) files a petition for relief in bankruptcy on its own behalf, or by a third party (d) makes an assignment for the benefit of creditors, or (e) dissolves or liquidates all or a majority of its assets.

**17. Governing Law.** This agreement and the sale and delivery of all Products hereunder shall be deemed to have taken place in and shall be governed and construed in accordance with the laws of the State of Ohio, as applicable to contracts executed and wholly performed therein and without regard to conflicts of laws principles. Buyer irrevocably agrees and consents to the exclusive jurisdiction and venue of the courts of Cuyahoga County, Ohio with respect to any dispute, controversy or claim arising out of or relating to this agreement.

**18. Indemnity for Infringement of Intellectual Property Rights.** Seller shall have no liability for infringement of any patents, trademarks, copyrights, trade dress, trade secrets or similar rights except as provided in this Section. Seller will defend and indemnify Buyer against allegations of infringement of U.S. patents, U.S. trademarks, copyrights, trade dress and trade secrets ("Intellectual Property Rights"). Seller will defend at its expense and will pay the cost of any settlement or damages awarded in an action brought against Buyer based on an allegation that a Product sold pursuant to this Agreement infringes the Intellectual Property Rights of a third party. Seller's obligation to defend and indemnify Buyer is contingent on Buyer notifying Seller within ten (10) days after Buyer becomes aware of such allegations of infringement, and Seller having sole control over the defense of any allegations or actions including all negotiations for settlement or compromise. If a Product is subject to a claim that it infringes the Intellectual Property Rights of a third party, Seller may, at its sole expense and option, procure for Buyer the right to continue using the Product, replace or modify the Product so as to make it noninfringing, or offer to accept return of the Product and return the purchase price less a reasonable allowance for depreciation. Notwithstanding the foregoing, Seller shall have no liability for claims of infringement based on information provided by Buyer, or directed to Products delivered hereunder for which the designs are specified in whole or part by Buyer, or infringements resulting from the modification, combination or use in a system of any Product sold hereunder. The foregoing provisions of this Section shall constitute Seller's sole and exclusive liability and Buyer's sole and exclusive remedy for infringement of Intellectual Property Rights.

**19. Entire Agreement.** This agreement contains the entire agreement between the Buyer and Seller and constitutes the final, complete and exclusive expression of the terms of sale. All prior or contemporaneous written or oral agreements or negotiations with respect to the subject matter are herein merged.

**20. Compliance with Law, U. K. Bribery Act and U.S. Foreign Corrupt Practices Act.** Buyer agrees to comply with all applicable laws and regulations, including both those of the United Kingdom and the United States of America, and of the country or countries of the Territory in which Buyer may operate, including without limitation the U. K. Bribery Act, the U.S. Foreign Corrupt Practices Act ("FCPA") and the U.S. Anti-Kickback Act (the "Anti-Kickback Act"), and agrees to indemnify and hold harmless Seller from the consequences of any violation of such provisions by Buyer, its employees or agents. Buyer acknowledges that they are familiar with the provisions of the U. K. Bribery Act, the FCPA and the Anti-Kickback Act, and certifies that Buyer will adhere to the requirements thereof. In particular, Buyer represents and agrees that Buyer shall not make any payment or give anything of value, directly or indirectly to any governmental official, any foreign political party or official thereof, any candidate for foreign political office, or any commercial entity or person, for the purpose of influencing such person to purchase products or otherwise benefit the business of Seller.



# Custom Modifications Engineered to Order

*exclusively for Atlas H Series cylinders*

Looking for an NFPA Interchangeable  
non Tie Rod Cylinder?

***Consider a H B modification***

- Easier to service
- Offers a clean appearance
- Improves aesthetics particularly in longer stroke applications

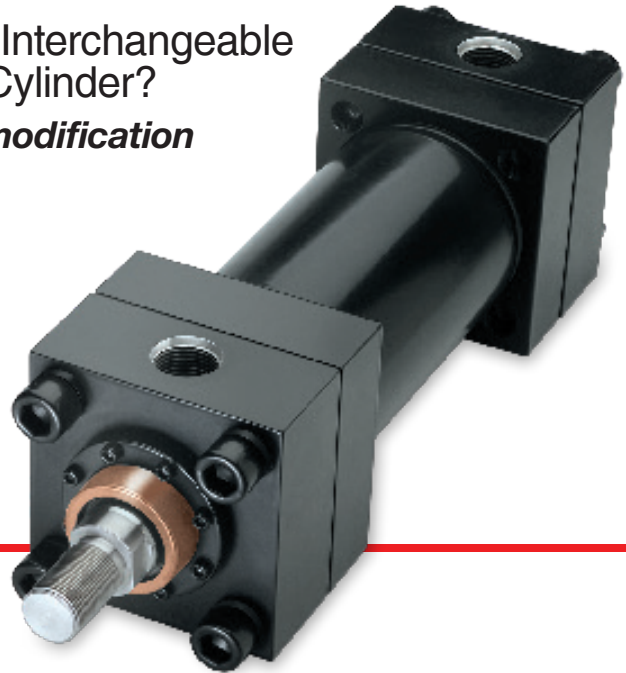

Looking to cleanly integrate your H into  
your Electrohydraulic system?

***Consider a H X modification***

Engineered for your feedback/  
control systems with  
transducer, valve manifold and  
hydraulic plumbing options.

All units are electronically  
tested to verify your required  
outputs prior to shipment.

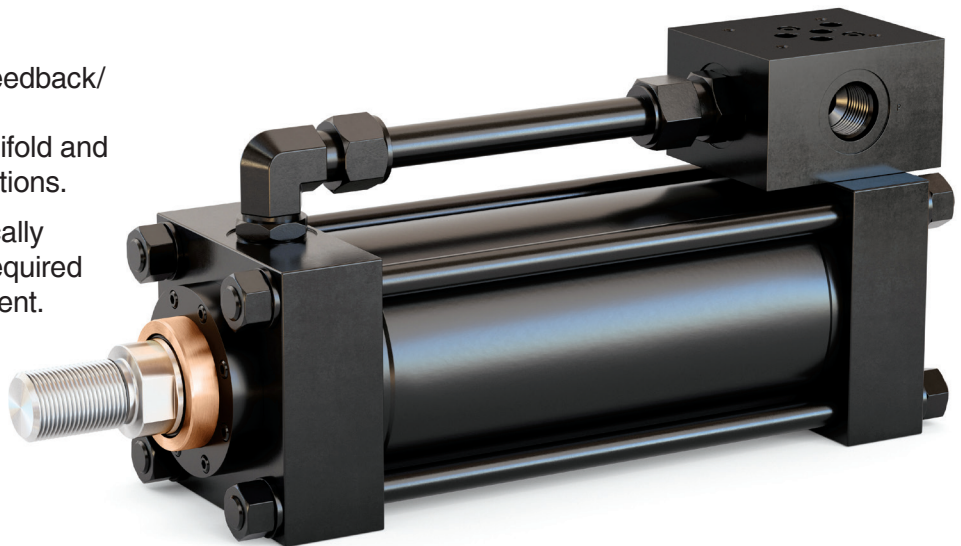

**Consult your local Atlas representative today**

All specifications and information subject to  
change without notice or prior obligation.

Catalog HY08-AC1314-1/NA  
05/18

# **ATLAS**<sup>TM</sup> **CYLINDERS**

500 S. Wolf Rd.  
Des Plaines, IL 60016 USA  
Tel.: (847) 298-2400  
Fax.: (800) 892-1008

[www.atlas-cylinders.com](http://www.atlas-cylinders.com) • [atlasclmktg@parker.com](mailto:atlasclmktg@parker.com)